

CSP package Class-D Mono Speaker Amplifier Series

BD546xGUL/BD27400GUL Evaluation Board Information

BD546xGUL-EVK-001/BD27400GUL-EVK-001

● General

BD546xGUL series, BD27400GUL are a wafer-level CSP packaged low voltage monaural Class-D speaker amplifier for mobile phone, portable type electric devices.

BD5460/61GUL are a fixed gain type. BD27400GUL is a variable gain type, BD5465/66/67/68/69GUL are fixed gain with ALC type.

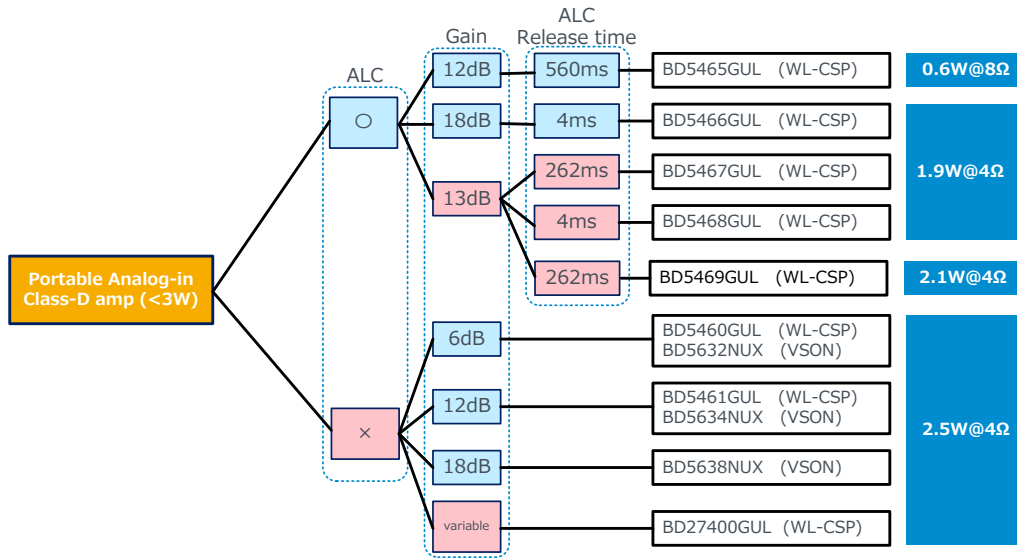

● Index

- General 1
- Index 1
- Conditions 1
- Circuit Diagram..... 2
- PCB layout 3
- Usage 4
- BOM List 4

● Conditions

Item	Symbol	Range		Unit
		BD5460GUL BD5461GUL	BD27400GUL BD5465GUL BD5466GUL BD5467GUL BD5468GUL BD5469GUL	
Power Supply Voltage	V _{DD}	+2.5 ~ +5.5		V
Input Voltage	V _{IN}	-0.1 ~ V _{DD} +0.1	-0.3 ~ V _{DD} +0.3	V
Load impedance	R _L	4 ≤		Ω

This document is information of the evaluation board when we evaluated the device.
 This information will help you when designing your evaluation board.
 Notice, the evaluation board is not available for sale.

●Circuit Diagram

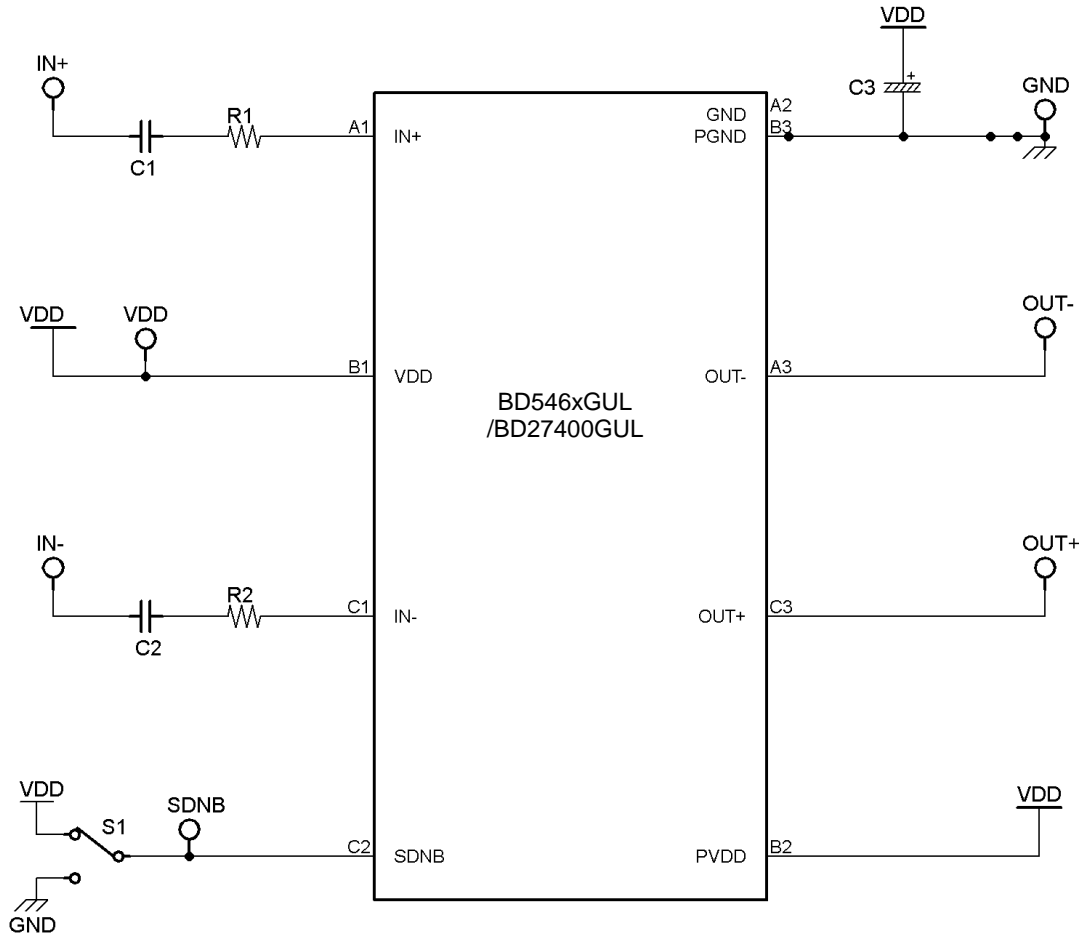

●PCB layout

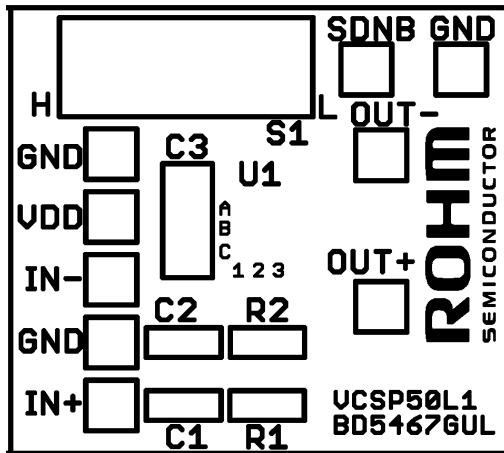

TOP SILKSCREEN (BD546xGUL) – TOP VIEW

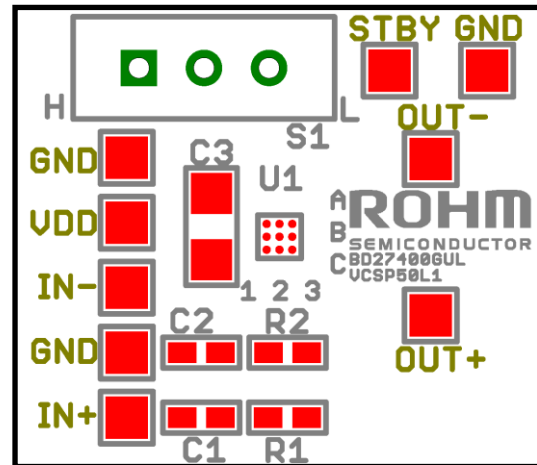

TOP SILKSCREEN (BD27400GUL) – TOP VIEW

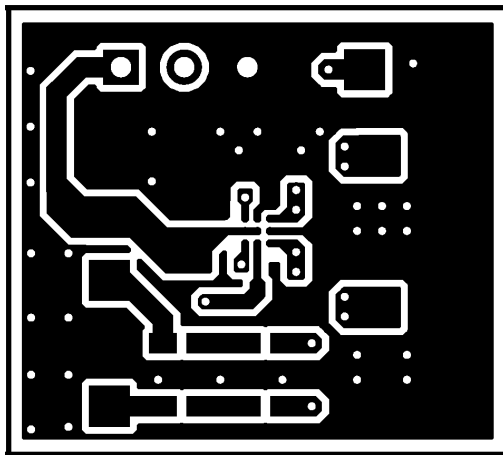

TOP LAYER (BD546xGUL) – TOP VIEW

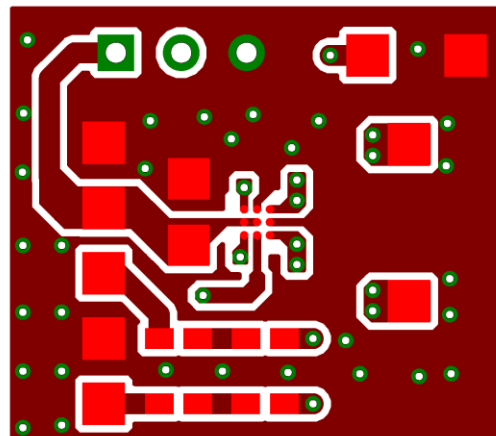

TOP LAYER (BD27400GUL) – TOP VIEW

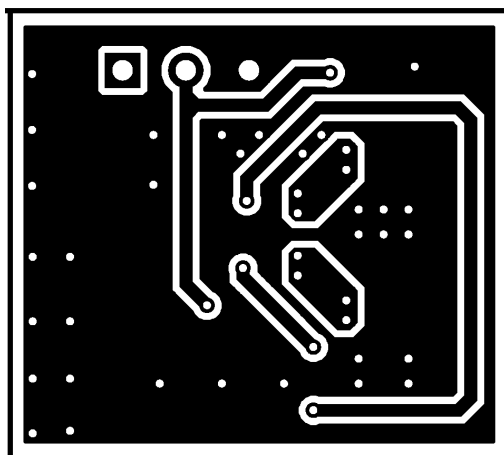

BOTTOM LAYER (BD546xGUL) – TOP VIEW

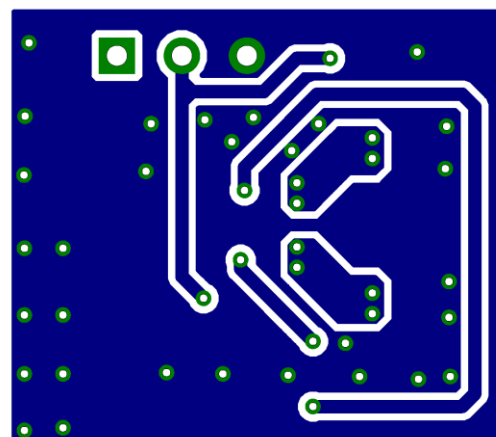

BOTTOM LAYER (BD27400GUL) – TOP VIEW

● Usage

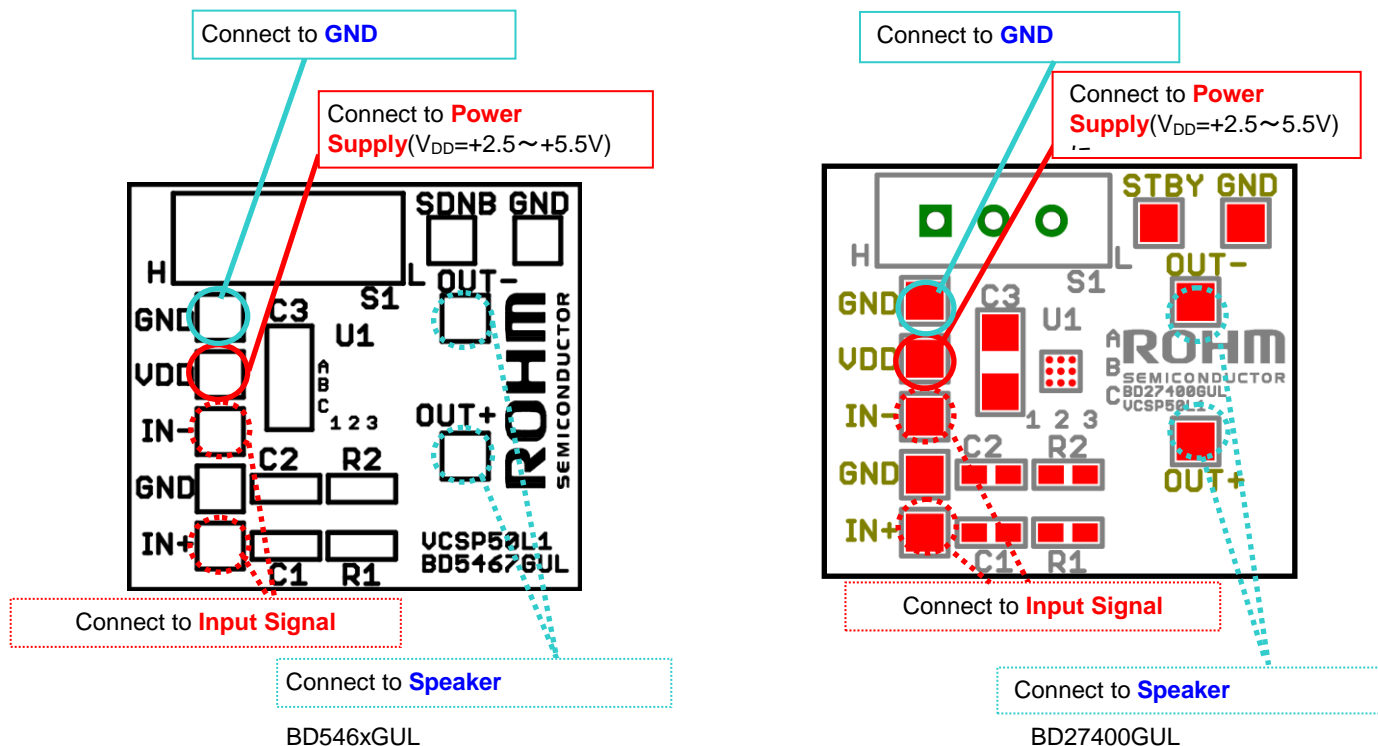

● BOM List

· BD546xGUL

No.	Instance	Type	Value	Package/SMD Size
1	U1	IC	—	VCSP50L1
2	C1, C2	Ceramic Capacitor	0.1 μ F	1608
1	C3	Tantalum Capacitor	10 μ F	3216
2	R1, R2	Register	Short	—

· BD27400GUL

No.	Instance	Type	Value	Package/SMD size
1	U1	IC	—	VCSP50L1
2	C1, C2	Ceramic Capacitor	0.1 μ F	1608
1	C3	Tantalum Capacitor	10 μ F	3216
2	R1, R2	Register	150K Ω	1608

Our recommended LC filter parts are below.

【Coil】 L=22 μ H large current type. (TDK SLF12575T-220M4R0)

【Capacitor】 C=1 μ F Ceramic Capacitor

At this condition, $F_c=34kHz$

Notes

- 1) The information contained herein is subject to change without notice.
- 2) Before you use our Products, please contact our sales representative and verify the latest specifications :
- 3) Although ROHM is continuously working to improve product reliability and quality, semiconductors can break down and malfunction due to various factors.
Therefore, in order to prevent personal injury or fire arising from failure, please take safety measures such as complying with the derating characteristics, implementing redundant and fire prevention designs, and utilizing backups and fail-safe procedures. ROHM shall have no responsibility for any damages arising out of the use of our Products beyond the rating specified by ROHM.
- 4) Examples of application circuits, circuit constants and any other information contained herein are provided only to illustrate the standard usage and operations of the Products. The peripheral conditions must be taken into account when designing circuits for mass production.
- 5) The technical information specified herein is intended only to show the typical functions of and examples of application circuits for the Products. ROHM does not grant you, explicitly or implicitly, any license to use or exercise intellectual property or other rights held by ROHM or any other parties. ROHM shall have no responsibility whatsoever for any dispute arising out of the use of such technical information.
- 6) The Products specified in this document are not designed to be radiation tolerant.
- 7) For use of our Products in applications requiring a high degree of reliability (as exemplified below), please contact and consult with a ROHM representative : transportation equipment (i.e. cars, ships, trains), primary communication equipment, traffic lights, fire/crime prevention, safety equipment, medical systems, servers, solar cells, and power transmission systems.
- 8) Do not use our Products in applications requiring extremely high reliability, such as aerospace equipment, nuclear power control systems, and submarine repeaters.
- 9) ROHM shall have no responsibility for any damages or injury arising from non-compliance with the recommended usage conditions and specifications contained herein.
- 10) ROHM has used reasonable care to ensure the accuracy of the information contained in this document. However, ROHM does not warrants that such information is error-free, and ROHM shall have no responsibility for any damages arising from any inaccuracy or misprint of such information.
- 11) Please use the Products in accordance with any applicable environmental laws and regulations, such as the RoHS Directive. For more details, including RoHS compatibility, please contact a ROHM sales office. ROHM shall have no responsibility for any damages or losses resulting non-compliance with any applicable laws or regulations.
- 12) When providing our Products and technologies contained in this document to other countries, you must abide by the procedures and provisions stipulated in all applicable export laws and regulations, including without limitation the US Export Administration Regulations and the Foreign Exchange and Foreign Trade Act.
- 13) This document, in part or in whole, may not be reprinted or reproduced without prior consent of ROHM.



Thank you for your accessing to ROHM product informations.
More detail product informations and catalogs are available, please contact us.

ROHM Customer Support System

<http://www.rohm.com/contact/>