



AC/DC Convertor
Non-Isolated PWM type, 8.4 W (24 V/0.35 A)
BM2PDA1Y-Z Evaluation Board

<High Voltage Safety Precautions>

◇ Read all safety precautions before use

Please note that this document covers only the **BM2PDA1Y-Z** evaluation board (BM2PDA1Y-EVK-001) and its functions. For additional information, please refer to the datasheet.

To ensure safe operation, please carefully read all precautions before handling the evaluation board



Depending on the configuration of the board and voltages used,

Potentially lethal voltages may be generated.

Therefore, please make sure to read and observe all safety precautions described in the red box below.

Before Use

- [1] Verify that the parts/components are not damaged or missing (i.e. due to the drops).
- [2] Check that there are no conductive foreign objects on the board.
- [3] Be careful when performing soldering on the module and/or evaluation board to ensure that solder splash does not occur.
- [4] Check that there is no condensation or water droplets on the circuit board.

During Use

- [5] Be careful to not allow conductive objects to come into contact with the board.
- [6] **Brief accidental contact or even bringing your hand close to the board may result in discharge and lead to severe injury or death.**

Therefore, DO NOT touch the board with your bare hands or bring them too close to the board.

In addition, as mentioned above please exercise extreme caution when using conductive tools such as tweezers and screwdrivers.

- [7] If used under conditions beyond its rated voltage, it may cause defects such as short-circuit or, depending on the circumstances, explosion or other permanent damages.
- [8] Be sure to wear insulated gloves when handling is required during operation.

After Use

- [9] The ROHM Evaluation Board contains the circuits which store the high voltage. Since it stores the charges even after the connected power circuits are cut, please discharge the electricity after using it, and please deal with it after confirming such electric discharge.
- [10] Protect against electric shocks by wearing insulated gloves when handling.

This evaluation board is intended for use only in research and development facilities and should be handled **only by qualified personnel familiar with all safety and operating procedures.**

We recommend carrying out operation in a safe environment that includes the use of high voltage signage at all entrances, safety interlocks, and protective glasses.

AC/DC Converter

Non-Isolated Buck Converter 24 V 8.4 W Output BM2PDA1Y-Z Evaluation Board

BM2PDA1Y-EVK-001

Feature

- (1) Adjustable Output Voltage with External Resistor
- (2) Frequency 65 kHz
- (3) Internal Start up Circuit 730 V(peak)
- (4) Internal Super Junction FET 730 V(peak) (Ron = 1.2 Ω)
- (5) Internal Current Sense Resistor (Detection Current 0.93 A)
- (6) Contributes to Low EMI by Internal Hopping Function



Figure 1. BM2PDA1Y-EVK-001

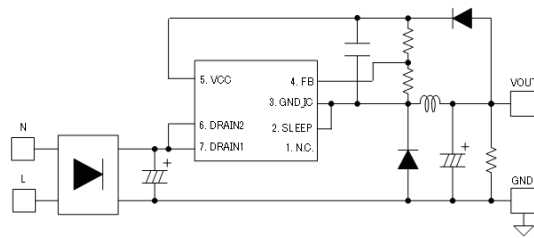

Figure 2. BM2PDA1Y-EVK-001 Simple Schematic

Specification

Table 1. Input Range

Parameter	Min	Typ	Max	Units	Conditions
Input Voltage Range	90	230	264	Vac	
Input Frequency Range	47	50 / 60	63	Hz	
Operating Temperature	-10	25	+65	°C	

Table 2. Evaluation board specification

These are representative values and not a guarantee of the characteristics, unless stated otherwise use $V_{IN} = 230 \text{ Vac}$, $I_{OUT} = 0.35 \text{ A}$, $T_a = 25 \text{ °C}$.

Parameter	Min	Typ	Max	Units	Conditions
Output Voltage	22.08	24.0	25.2	V	
Output Maximum Power	-	-	8.4	W	
Output Current Range ^(Note 1)	0	-	0.35	A	
No Load Power Consumption	-	100	-	mW	$I_{OUT} = 0 \text{ A}$
Efficiency	-	89	-	%	
Output Ripple Voltage ^(Note 2)	-	-	100	mVpp	

(Note 1) Adjust the operating time so that surface temperature of no component exceeds 105 °C

(Note 2) Do not consider spike noise

Operation Procedure

1. Operation equipment

- (1) AC power supply 90 Vac to 264 Vac, 15 W or more
- (2) Electronic Load capacity 0.35 A
- (3) Multimeter

2. Connection Instruments

- (1) Turn off each power supply and connect the measuring instrument as shown below.
- (2) Turn on the power supply setting between 90 Vac to 264 Vac
- (3) Turn on the electrical load setting between 0 to 0.35 A.
- (4) Connect the multimeter directly to the output and check the voltage by sensing.



Figure 3. Connection Circuit

Circuit

$V_{IN} = 90$ to 264 Vac, $V_{OUT} = 24$ V

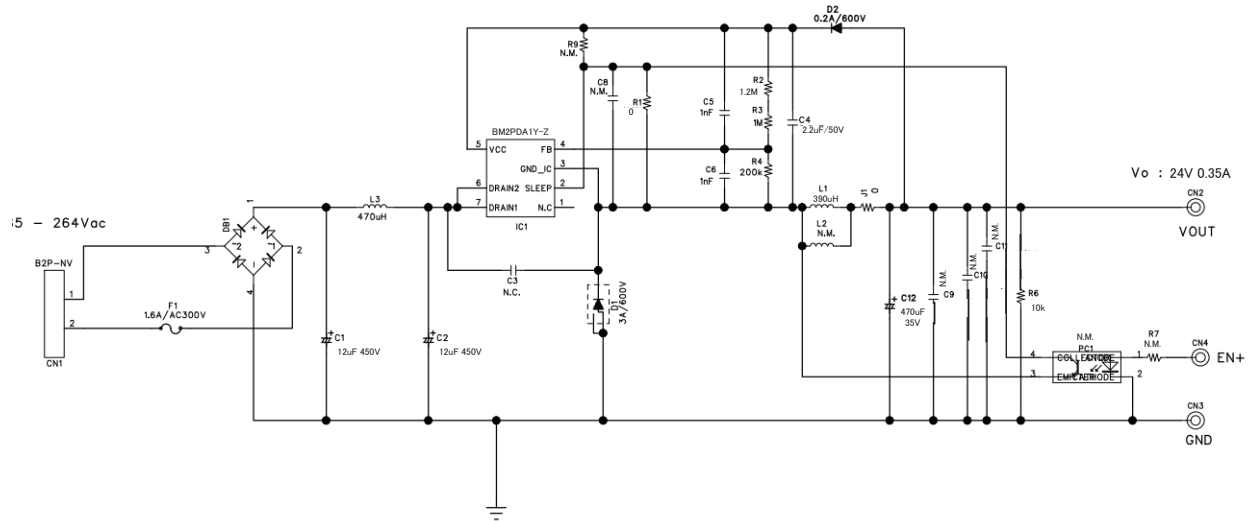

BOM List

Item	Specifications	Parts name	Manufacture	
Capacitor	C1	12 μ F, 450 V	UCY2W120MP01TD	NICHICON
	C2	12 μ F, 450 V	UCY2W120MP01TD	NICHICON
	C3	-	NON MOUNTED	-
	C4	2.2 μ F, 50 V	UMK316B7225KL-T	TAIYO YUDEN
	C5	1000 pF, 100 V	HMK107B7102KA-T	TAIYO YUDEN
	C6	1000 pF, 100 V	HMK107B7102KA-T	TAIYO YUDEN
	C8	-	NON MOUNTED	-
	C9	-	NON MOUNTED	-
	C10	-	NON MOUNTED	-
	C11	-	NON MOUNTED	-
C12	470 μ F, 35 V	UPW1V471MPD	NICHICON	
Connector	CN1	-	B02P-NV	JST
Diode	D1	FRD, 3 A, 600 V	RFN3BM6S	ROHM
	D2	FRD, 0.2 A, 600 V	RFU02VSM6S	ROHM
	DB1	1 A, 800 V	D1UBA80	SHINDENGEN
Fuse	F1	1.6 A, 300 V	36911600000_	LITTELFUSE
IC	IC1	-	BM2PDA1Y-Z	ROHM
Jumper	J1	0 Ω	MCR18EZPJ000	ROHM
Inductor	L1	390 μ H	RFS1317-394KL	COIL CRAFT
	L2	-	NON MOUNTED	-
	L3	470 μ H	7447462471_	WURTH ELECTRONIK
PhotoCoupler	PC1	-	NON MOUNTED	-
PCB	PCB1	-	PCB0178	ROHM
Resistor	R1	-	SHORT	-
	R2	1.2 M Ω	MCR03EZPFX1204	ROHM
	R3	1 M Ω	MCR03EZPFX1004	ROHM
	R4	200 k Ω	MCR03EZPFX2003	ROHM
	R6	10 k Ω	MCR18EZPJ103	ROHM
	R7	-	NON MOUNTED	-
R9	-	NON MOUNTED	-	

Layout

Size 70 mm x 30 mm

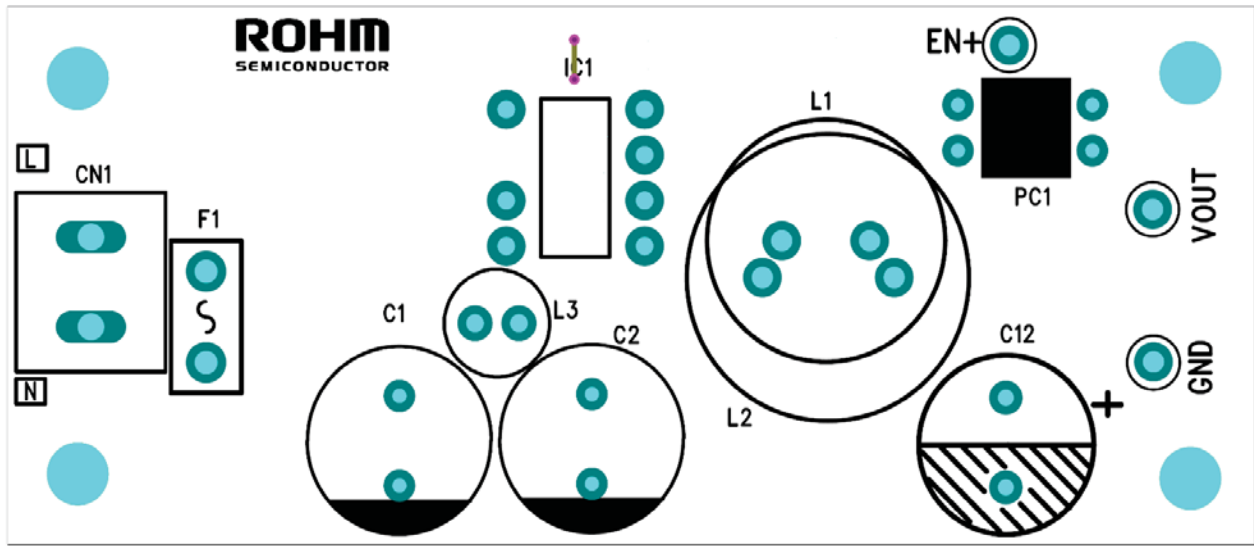

Figure 5. Top Silkscreen (Top view)

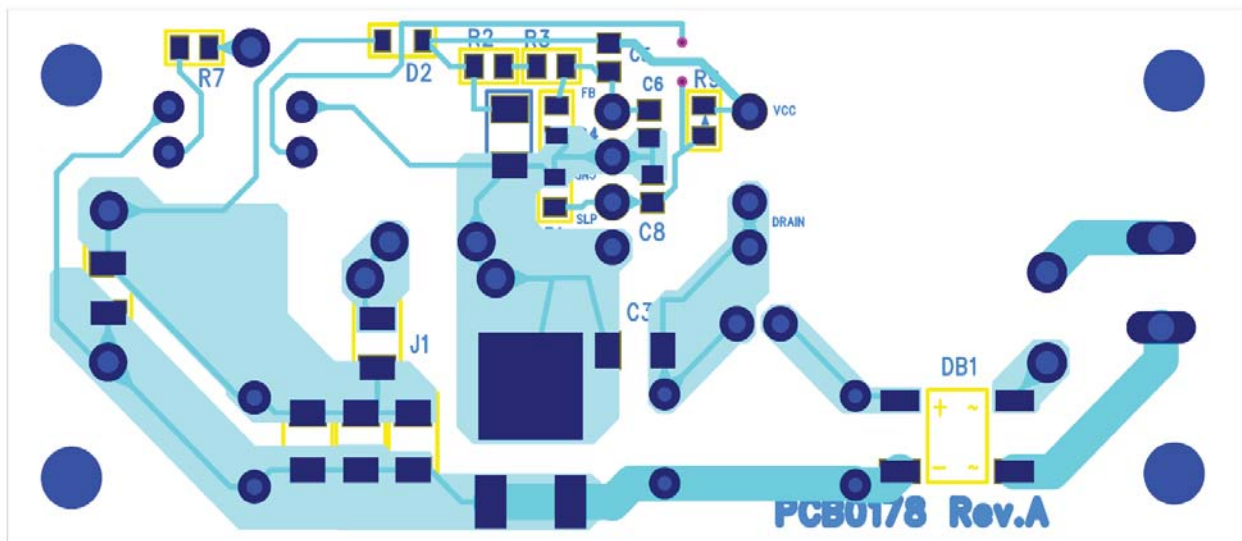

Figure 6. Bottom Layout (Bottom view)

BM2Pxx1Y Overview

Features

- PWM Current Mode
- Built-in Frequency Hopping Function
- Burst Operation at Light Load
- Built-in 730 V(peak) Starter Circuit
- Built-in 730 V(peak) Super Junction MOSFET
- VCC UVLO (Under Voltage Lockout)
- VCC OVP (Over Voltage Protection)
- Over Current Limiter Function per Cycle
- Soft Start Function
- Sleep Mode

Key Specifications

- Operating Power Supply Voltage Range

VCC	11.10 V to 26.00 V
DRAIN	730 V(peak) (Max)
- Operating Current (Normal): 650 μA (Typ)
- Operating Current (Burst): 350 μA (Typ)
- Operating Current (Sleep): 65 μA (Typ)
- Switching Frequency: 25 kHz / 65 kHz (Typ)
- Operation Temperature: -40 °C to +105 °C
- MOSFET ON Resistance: 1.2 Ω (Typ)

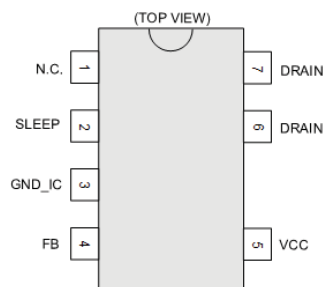

Figure 7. Pin Configuration

Application

Washing machine, Air conditioner, Other white goods

Package

DIP7K

W(Typ) x D(Typ) x H(Typ)

9.27 mm x 6.35 mm x 8.63 mm

Pitch 2.54 mm



Line Up

Model Name	Switching Frequency	Frequency Reduction	OCP Current
BM2PAA1Y-Z	65 kHz	O	1.76 A
BM2PAB1Y-Z	25 kHz	-	
BM2PDA1Y-Z	65 kHz	O	0.93 A
BM2PDB1Y-Z	25 kHz	-	

Table 3. BM2Pxx1Y-Z Pin Description

No.	Name	I/O	Function
1	N.C.	-	Non connection
2	SLEEP	I	Sleep/Normal modes witching pin
3	GND_IC	I/O	GND pin
4	FB	I	Output voltage feedback pin
5	VCC	I	Input voltage pin
6	DRAIN	I/O	MOSFET drain pin
7	DRAIN	I/O	MOSFET drain pin

Measurement Data

Constant Load Regulations

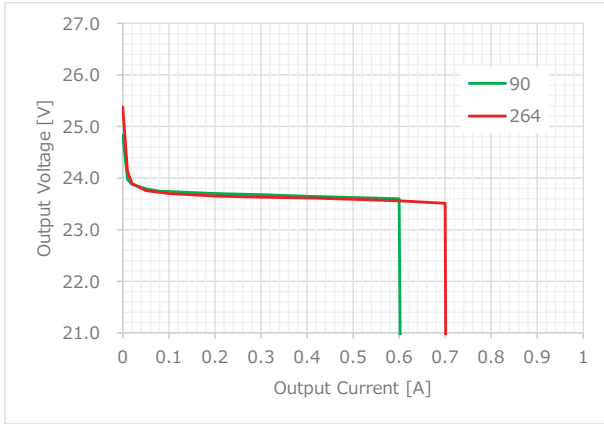

Figure 8. IOU_T vs. V_{OUT}

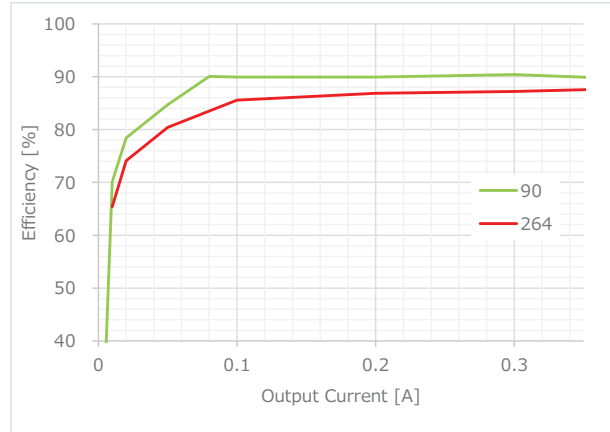

Figure 9. IOU_T vs. Efficiency

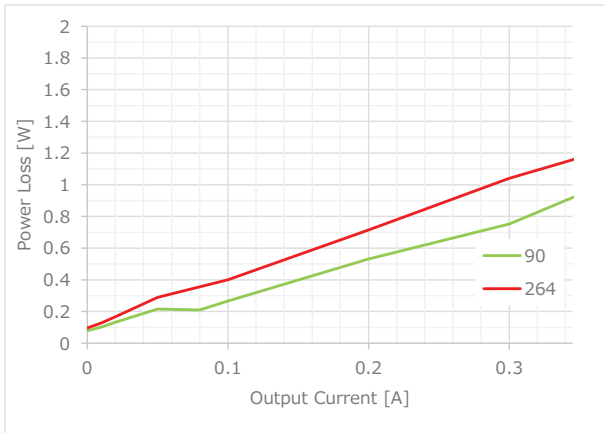

Figure 10. IOU_T vs. Power

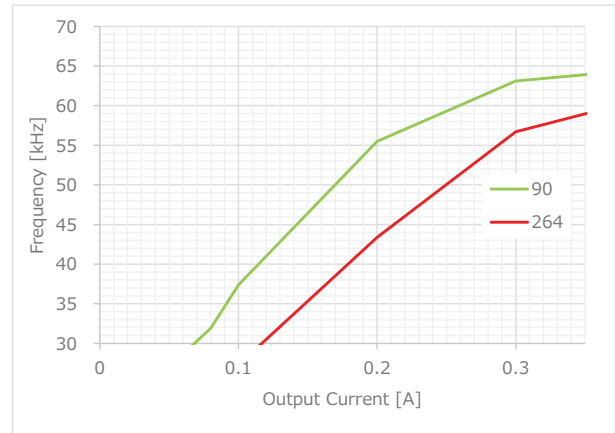

Figure 11. IOU_T vs. Frequency

Measurement Data - Continued

Waveform

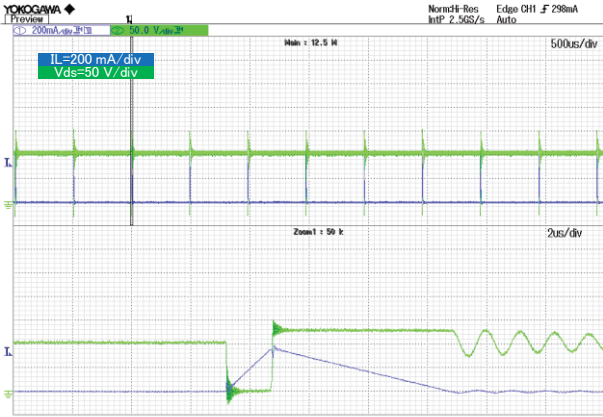

Figure 12 Vds and IL
VIN = 90 Vac, IOUt = 0 A



Figure 13. Vds and IL
VIN = 264 Vac, IOUt = 0 A

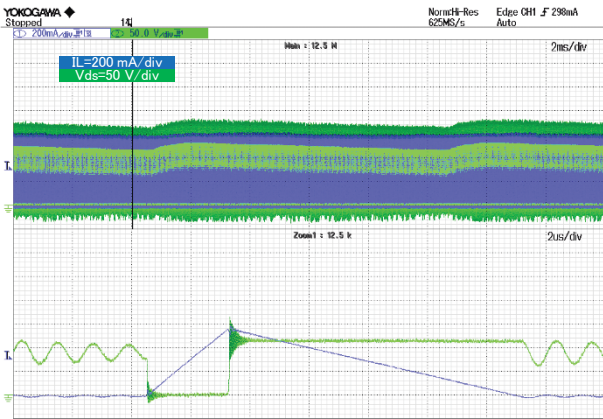

Figure 14. Vds and IL
VIN = 90 Vac, IOUt = 0.2 A

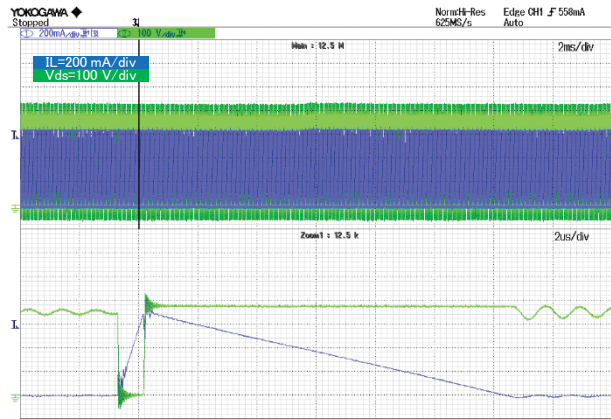

Figure 15. Vds and IL
VIN = 264 Vac, IOUt = 0.2 A

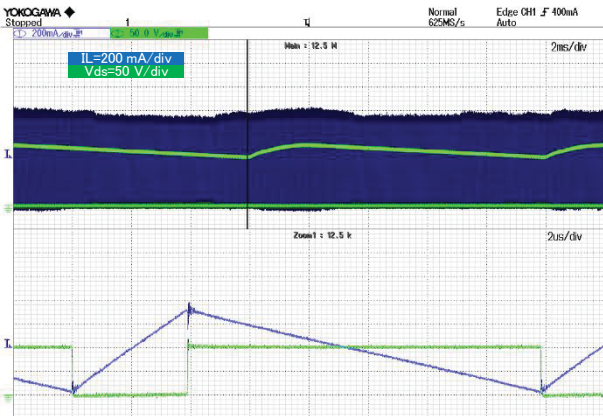

Figure 16. Vds and IL
VIN = 90 Vac, IOUt = 0.35 A

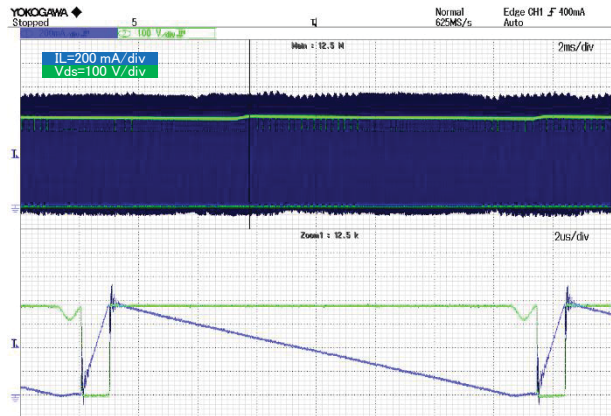

Figure 17. Vds and IL
VIN = 264 Vac, IOUt = 0.35 A

Measurement Data - Continued

Waveform (Start Up)

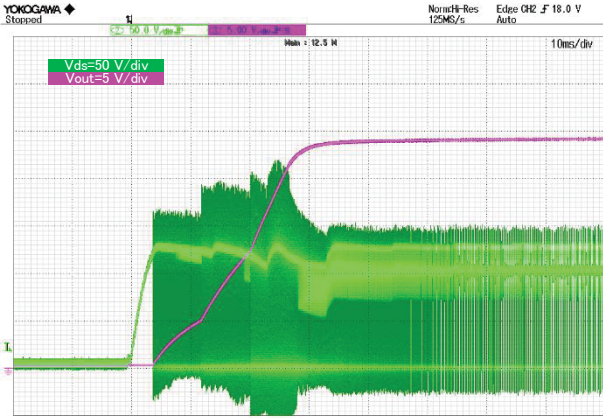

Figure 18. Vds and Vout
VIN = 90 Vac, IOUt = 0 A

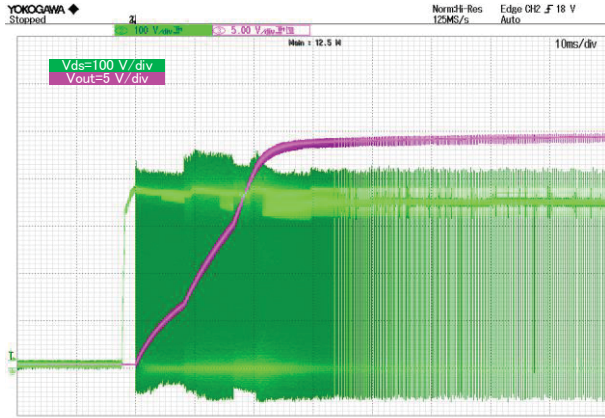

Figure 19. Vds and Vout
VIN = 264 Vac, IOUt = 0 A

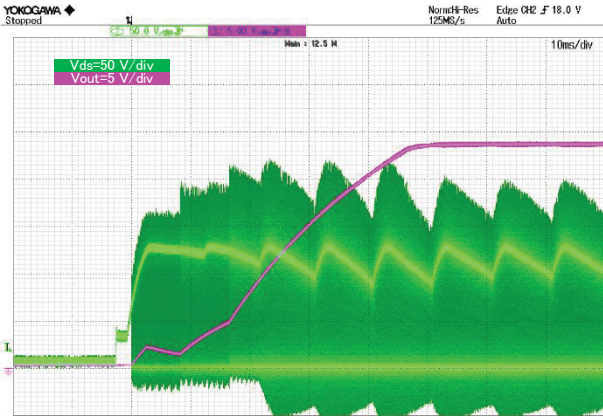

Figure 20. Vds and Vout
VIN = 90 Vac, IOUt = 0.35 A

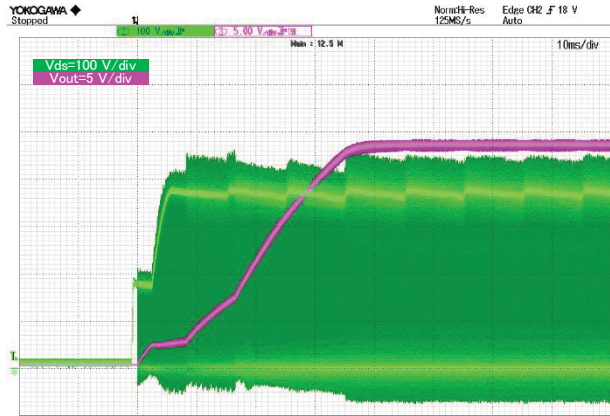

Figure 21. Vds and Vout
VIN = 264 Vac, IOUt = 0.35 A

Measurement Data - Continued

Waveform (Load Response)

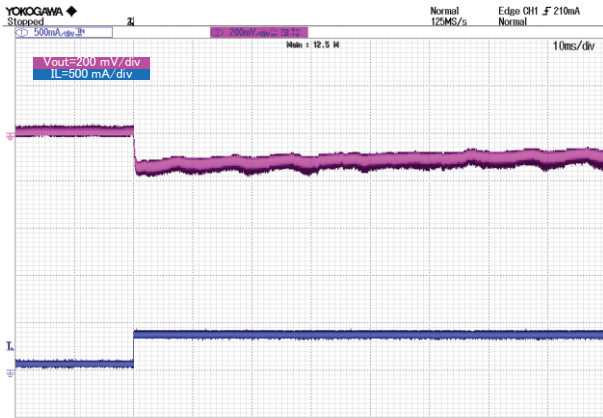

Figure 22. Iout and Vout (5 MHz Filter)
VIN = 90 Vac, IOU_T = 0.05 A to 0.35 A

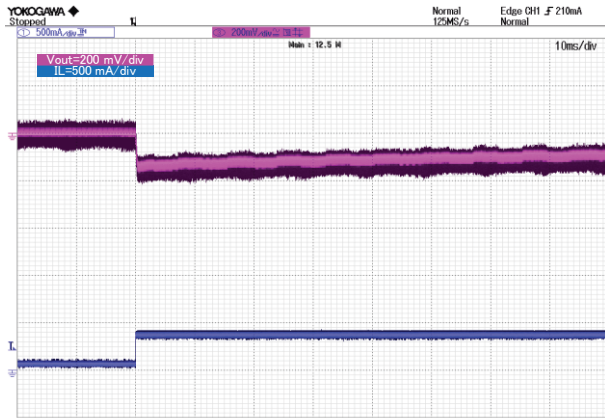

Figure 23. Iout and Vout (5 MHz Filter)
VIN = 264 Vac, IOU_T = 0.05 A to 0.35 A

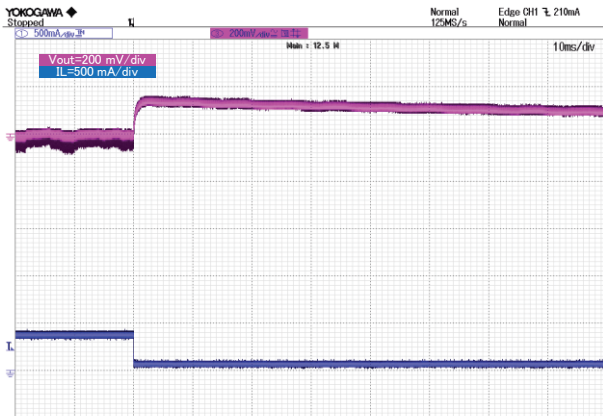

Figure 24. Iout and Vout (5 MHz Filter)
VIN = 90 Vac, IOU_T = 0.35 A to 0.05 A

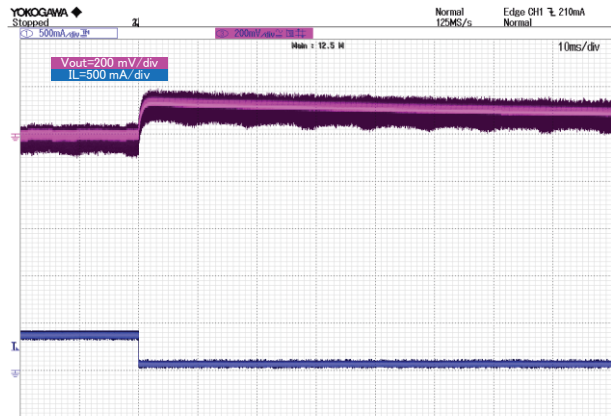

Figure 25. Iout and Vout (5 MHz Filter)
VIN = 264 Vac, IOU_T = 0.35 A to 0.05 A

Measurement Data - Continued

Waveform (Ripple Voltage)

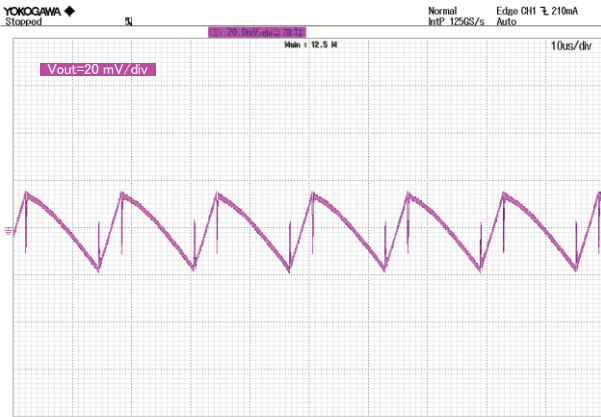

Figure 26. Vout Ripple Voltage (5 MHz Filter)
VIN = 90 Vac, IOUT = 0.35 A

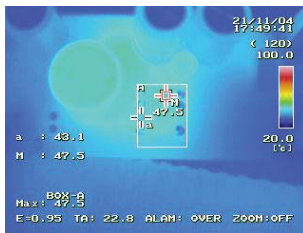

Figure 27. Vout Ripple Voltage (5MHz filter)
VIN = 264 Vac, IOUT = 0.35 A

Operation Temperature

Condition Iout=0.35 A. 20 min

VIN=90 Vac



IC 47.5 °C

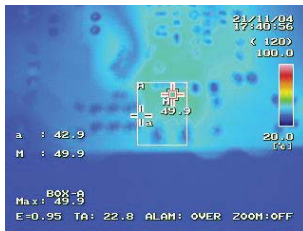

Diode 49.9 °C

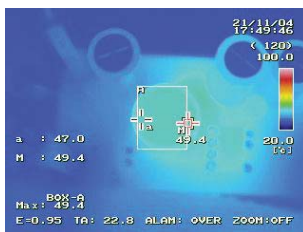

Inductor 49.4 °C

VIN= 264 Vac



IC 51.4 °C



Diode 53.9 °C



Inductor 57.9 °C

Figure 28. Each device Temperature with maximum output current

Consider selecting parts after checking the temperature range of the parts used.

Measurement Data - Continued

EMI

Condition

Vin = 90 Vac

Iout = 0.35 A

Margin

QP=26.4 dB (1.42 MHz)

AV=23.1 dB (3.77 MHz)

Data Comment :
 Limit1 : CISPR Pub 22 Class B
 Limit2 : CISPR Pub 22 Class B (AV)

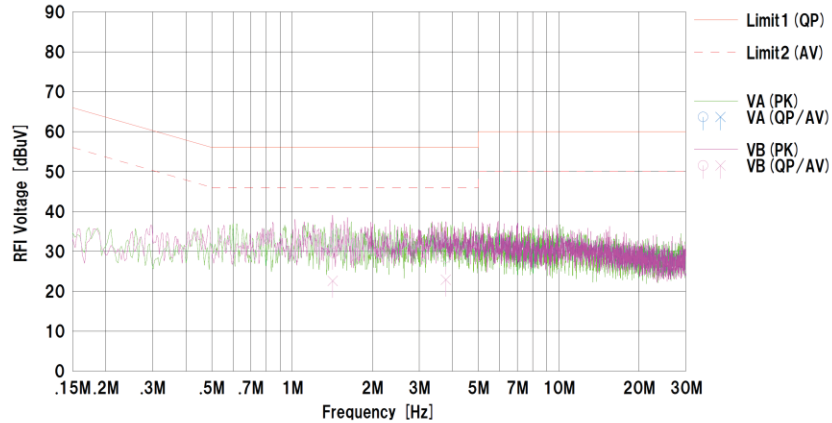

No.	Freq. [MHz]	Reading			C.Fac	Results		Limit		Margin		Phase	Comment
		<QP> [dBuV]	<AV> [dBuV]	[dB]		<QP> [dBuV]	<AV> [dBuV]	<QP> [dB]	<AV> [dB]				
1	1.42035	19.1	12.1	10.5	23.5	22.5	56.0	46.0	26.4	23.4	VB		
2	3.77461	17.8	12.3	10.6	28.4	22.9	56.0	46.0	27.6	23.1	VB		

Figure 29. Conduction Noise VIN = 90 Vac

Condition

Vin = 264 Vac

Iout = 0.35 A

Margin

QP=17.8 dB (0.94 MHz)

AV=17.1 dB (4.36 MHz)

Data Comment :
 Limit1 : CISPR Pub 22 Class B
 Limit2 : CISPR Pub 22 Class B (AV)

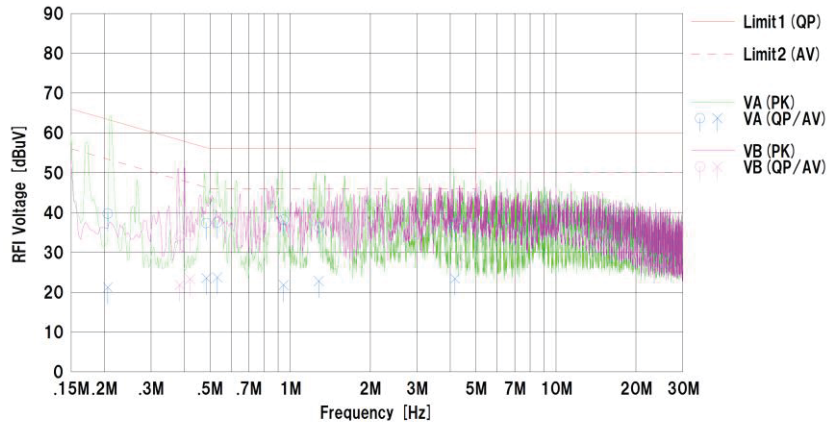

No.	Freq. [MHz]	Reading			C.Fac	Results		Limit		Margin		Phase	Comment
		<QP> [dBuV]	<AV> [dBuV]	[dB]		<QP> [dBuV]	<AV> [dBuV]	<QP> [dB]	<AV> [dB]				
1	0.20596	29.5	11.0	10.2	39.7	21.2	63.3	53.3	23.6	32.1	VA		
2	0.48426	27.0	13.2	10.3	37.3	23.5	56.2	46.2	18.9	22.7	VA		
3	0.53218	27.1	13.3	10.4	37.5	23.7	56.0	46.0	18.5	22.3	VA		
4	0.94448	27.8	11.4	10.4	38.2	21.8	56.0	46.0	17.8	24.2	VA		
5	1.28069	25.9	12.4	10.4	36.3	22.8	56.0	46.0	19.7	23.2	VA		
6	4.16758	26.2	12.8	10.6	36.8	23.4	56.0	46.0	19.2	22.6	VA		
7	0.38438	23.7	11.5	10.3	34.0	21.8	58.1	48.1	24.1	26.3	VB		
8	0.42058	23.9	13.0	10.3	34.2	23.3	57.4	47.4	23.2	24.1	VB		
9	4.35548	25.6	18.3	10.6	36.2	28.9	56.0	46.0	19.8	17.1	VB		

Figure 30. Conduction Noise VIN = 264 Vac

Revision History

Date	Rev.	Changes
Mar.2021	001	New Release
Nov. 2021	002	Max Output Power =10 W->8.4 W Max Output Current =0.417 A->0.35 A OCP Detection Current =1.0 A -> 0.93 A FET Withstand voltage =650 V-> 730 V(peak) Figure 8~30 modified

Notes

- 1) The information contained herein is subject to change without notice.
- 2) Before you use our Products, please contact our sales representative and verify the latest specifications :
- 3) Although ROHM is continuously working to improve product reliability and quality, semiconductors can break down and malfunction due to various factors.
Therefore, in order to prevent personal injury or fire arising from failure, please take safety measures such as complying with the derating characteristics, implementing redundant and fire prevention designs, and utilizing backups and fail-safe procedures. ROHM shall have no responsibility for any damages arising out of the use of our Products beyond the rating specified by ROHM.
- 4) Examples of application circuits, circuit constants and any other information contained herein are provided only to illustrate the standard usage and operations of the Products. The peripheral conditions must be taken into account when designing circuits for mass production.
- 5) The technical information specified herein is intended only to show the typical functions of and examples of application circuits for the Products. ROHM does not grant you, explicitly or implicitly, any license to use or exercise intellectual property or other rights held by ROHM or any other parties. ROHM shall have no responsibility whatsoever for any dispute arising out of the use of such technical information.
- 6) The Products specified in this document are not designed to be radiation tolerant.
- 7) For use of our Products in applications requiring a high degree of reliability (as exemplified below), please contact and consult with a ROHM representative : transportation equipment (i.e. cars, ships, trains), primary communication equipment, traffic lights, fire/crime prevention, safety equipment, medical systems, servers, solar cells, and power transmission systems.
- 8) Do not use our Products in applications requiring extremely high reliability, such as aerospace equipment, nuclear power control systems, and submarine repeaters.
- 9) ROHM shall have no responsibility for any damages or injury arising from non-compliance with the recommended usage conditions and specifications contained herein.
- 10) ROHM has used reasonable care to ensure the accuracy of the information contained in this document. However, ROHM does not warrants that such information is error-free, and ROHM shall have no responsibility for any damages arising from any inaccuracy or misprint of such information.
- 11) Please use the Products in accordance with any applicable environmental laws and regulations, such as the RoHS Directive. For more details, including RoHS compatibility, please contact a ROHM sales office. ROHM shall have no responsibility for any damages or losses resulting non-compliance with any applicable laws or regulations.
- 12) When providing our Products and technologies contained in this document to other countries, you must abide by the procedures and provisions stipulated in all applicable export laws and regulations, including without limitation the US Export Administration Regulations and the Foreign Exchange and Foreign Trade Act.
- 13) This document, in part or in whole, may not be reprinted or reproduced without prior consent of ROHM.



Thank you for your accessing to ROHM product informations.
More detail product informations and catalogs are available, please contact us.

ROHM Customer Support System

<http://www.rohm.com/contact/>