

# Linear Regulator Application Information

IC Product Name	BD00IA5WEFJ
Topology	LDO Linear Regulator
Type	Voltage source

	Input	Output
1	2.4V to 5.5V	1.0V, 500mA <sup>*1</sup>
2	2.4V to 5.5V	1.2V, 500mA <sup>*1</sup>
3	2.4V to 5.5V	1.8V, 500mA <sup>*1</sup>
4	3.1V to 5.5V	2.5V, 500mA <sup>*1</sup>
5	3.6V to 5.5V	3.0V, 500mA <sup>*1</sup>
6	3.9V to 5.5V	3.3V, 500mA <sup>*1</sup>

\*1 Not to exceed power dissipation.

■ Typical Application Circuit

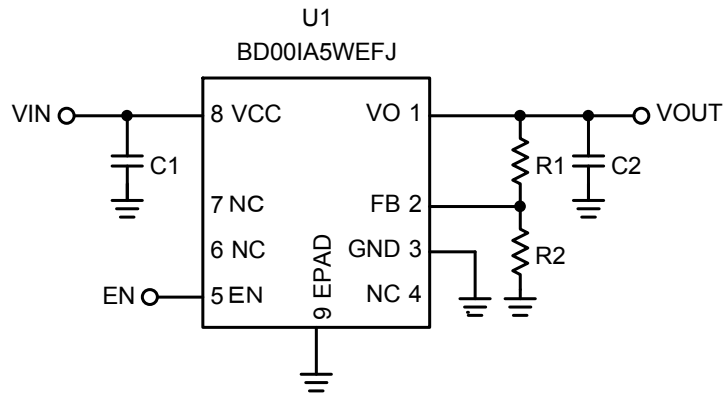

■ EN terminal setting

Terminal state	IC operation
2.4V ~ 5.5V	Normal operation
0V ~ 0.8V	Power down

■ Output voltage setting

$$V_{OUT} = \frac{R_1 + R_2}{R_2} \times 0.8 [V]$$

Input/output voltage conditions are required to satisfy the following equations:

$$V_{OUT} = 0.8V \sim (V_{IN} - 0.6)V \quad \text{at } I_O = 500mA$$

$$(V_{IN} - 0.6) \leq 4.5V$$

The use of resistors with  $R_1 + R_2 = 1k\Omega$  to  $90k\Omega$  recommended.

## ■ Bill of Materials

### 1. $V_O=1.0V$ ( $V_{IN}=2.4V$ to $5.5V$ )

Count	Reference Designator	Type	Value	Description	Manufacturer Part Number	Manufacturer	Configuration (mm)
1	C1	Ceramic Capacitor	2.2 $\mu$ F	10V, B, $\pm 10\%$	GRM219B11A225KA01	MURATA	2012
1	C2	Ceramic Capacitor	2.2 $\mu$ F	6.3V, B, $\pm 10\%$	GRM155B30J225KE95	MURATA	1005
1	R1	Resistor	3k $\Omega$	0.063W, 50V, 1%	MCR01MZPF3001	ROHM	1005
1	R2	Resistor	12k $\Omega$	0.063W, 50V, 1%	MCR01MZPF1202	ROHM	1005
1	U1	IC	-	LDO Linear Regulator	BD00IA5WEFJ	ROHM	HTSOP-J8

### 2. $V_O=1.2V$ ( $V_{IN}=2.4V$ to $5.5V$ )

Count	Reference Designator	Type	Value	Description	Manufacturer Part Number	Manufacturer	Configuration (mm)
1	C1	Ceramic Capacitor	2.2 $\mu$ F	10V, B, $\pm 10\%$	GRM219B11A225KA01	MURATA	2012
1	C2	Ceramic Capacitor	2.2 $\mu$ F	6.3V, B, $\pm 10\%$	GRM155B30J225KE95	MURATA	1005
1	R1	Resistor	7.5k $\Omega$	0.063W, 50V, 1%	MCR01MZPF7501	ROHM	1005
1	R2	Resistor	15k $\Omega$	0.063W, 50V, 1%	MCR01MZPF1502	ROHM	1005
1	U1	IC	-	LDO Linear Regulator	BD00IA5WEFJ	ROHM	HTSOP-J8

### 3. $V_O=1.8V$ ( $V_{IN}=2.4V$ to $5.5V$ )

Count	Reference Designator	Type	Value	Description	Manufacturer Part Number	Manufacturer	Configuration (mm)
1	C1	Ceramic Capacitor	2.2 $\mu$ F	10V, B, $\pm 10\%$	GRM219B11A225KA01	MURATA	2012
1	C2	Ceramic Capacitor	2.2 $\mu$ F	6.3V, B, $\pm 10\%$	GRM188B30J225KE18	MURATA	1608
1	R1	Resistor	15k $\Omega$	0.063W, 50V, 1%	MCR01MZPF1502	ROHM	1005
1	R2	Resistor	12k $\Omega$	0.063W, 50V, 1%	MCR01MZPF1202	ROHM	1005
1	U1	IC	-	LDO Linear Regulator	BD00IA5WEFJ	ROHM	HTSOP-J8

### 4. $V_O=2.5V$ ( $V_{IN}=3.1V$ to $5.5V$ )

Count	Reference Designator	Type	Value	Description	Manufacturer Part Number	Manufacturer	Configuration (mm)
1	C1	Ceramic Capacitor	2.2 $\mu$ F	10V, B, $\pm 10\%$	GRM219B11A225KA01	MURATA	2012
1	C2	Ceramic Capacitor	2.2 $\mu$ F	6.3V, B, $\pm 10\%$	GRM188B30J225KE18	MURATA	1608
1	R1	Resistor	51k $\Omega$	0.063W, 50V, 1%	MCR01MZPF5102	ROHM	1005
1	R2	Resistor	24k $\Omega$	0.063W, 50V, 1%	MCR01MZPF2402	ROHM	1005
1	U1	IC	-	LDO Linear Regulator	BD00IA5WEFJ	ROHM	HTSOP-J8

### ■ Bill of Materials (continued)

#### 5. $V_O=3.0V$ ( $V_{IN}=3.6V$ to $5.5V$ )

Count	Reference Designator	Type	Value	Description	Manufacturer Part Number	Manufacturer	Configuration (mm)
2	C1, C2	Ceramic Capacitor	2.2 $\mu$ F	10V, B, $\pm$ 10%	GRM219B11A225KA01	MURATA	2012
1	R1	Resistor	33k $\Omega$	0.063W, 50V, 1%	MCR01MZPF3302	ROHM	1005
1	R2	Resistor	12k $\Omega$	0.063W, 50V, 1%	MCR01MZPF1202	ROHM	1005
1	U1	IC	-	LDO Linear Regulator	BD00IA5WEFJ	ROHM	HTSOP-J8

#### 6. $V_O=3.3V$ ( $V_{IN}=3.9V$ to $5.5V$ )

Count	Reference Designator	Type	Value	Description	Manufacturer Part Number	Manufacturer	Configuration (mm)
2	C1, C2	Ceramic Capacitor	2.2 $\mu$ F	10V, B, $\pm$ 10%	GRM219B11A225KA01	MURATA	2012
1	R1	Resistor	7.5k $\Omega$	0.063W, 50V, 1%	MCR01MZPF7501	ROHM	1005
1	R2	Resistor	2.4k $\Omega$	0.063W, 50V, 1%	MCR01MZPF2401	ROHM	1005
1	U1	IC	-	LDO Linear Regulator	BD00IA5WEFJ	ROHM	HTSOP-J8

### ■ Precautions for use

- (1) This document provides the BOM for evaluation boards. Small parts can also be selected for resistor, and capacitor.
- (2) When miniaturizing a resistor, consider decrease in rated power and withstand voltage.
- (3) When miniaturizing a ceramic capacitor, consider decrease in withstand voltage. In addition, the capacity may be decreased by DC bias characteristics, and the desired characteristics may not be obtained.
- (4) If ceramic capacitor models differ even when they have the same capacity and withstand voltage, the capacity may be decreased by DC bias characteristics depending on the model, and desired characteristics may not be obtained. Be sure to check the DC bias characteristics.
- (5) This circuit constant is the value for our evaluation board. It may be necessary to adjust the constant for the actual board. Carry out suitable evaluations.

## Notes

- 1) The information contained herein is subject to change without notice.
- 2) Before you use our Products, please contact our sales representative and verify the latest specifications :
- 3) Although ROHM is continuously working to improve product reliability and quality, semiconductors can break down and malfunction due to various factors.  
Therefore, in order to prevent personal injury or fire arising from failure, please take safety measures such as complying with the derating characteristics, implementing redundant and fire prevention designs, and utilizing backups and fail-safe procedures. ROHM shall have no responsibility for any damages arising out of the use of our Products beyond the rating specified by ROHM.
- 4) Examples of application circuits, circuit constants and any other information contained herein are provided only to illustrate the standard usage and operations of the Products. The peripheral conditions must be taken into account when designing circuits for mass production.
- 5) The technical information specified herein is intended only to show the typical functions of and examples of application circuits for the Products. ROHM does not grant you, explicitly or implicitly, any license to use or exercise intellectual property or other rights held by ROHM or any other parties. ROHM shall have no responsibility whatsoever for any dispute arising out of the use of such technical information.
- 6) The Products specified in this document are not designed to be radiation tolerant.
- 7) For use of our Products in applications requiring a high degree of reliability (as exemplified below), please contact and consult with a ROHM representative : transportation equipment (i.e. cars, ships, trains), primary communication equipment, traffic lights, fire/crime prevention, safety equipment, medical systems, servers, solar cells, and power transmission systems.
- 8) Do not use our Products in applications requiring extremely high reliability, such as aerospace equipment, nuclear power control systems, and submarine repeaters.
- 9) ROHM shall have no responsibility for any damages or injury arising from non-compliance with the recommended usage conditions and specifications contained herein.
- 10) ROHM has used reasonable care to ensure the accuracy of the information contained in this document. However, ROHM does not warrant that such information is error-free, and ROHM shall have no responsibility for any damages arising from any inaccuracy or misprint of such information.
- 11) Please use the Products in accordance with any applicable environmental laws and regulations, such as the RoHS Directive. For more details, including RoHS compatibility, please contact a ROHM sales office. ROHM shall have no responsibility for any damages or losses resulting from non-compliance with any applicable laws or regulations.
- 12) When providing our Products and technologies contained in this document to other countries, you must abide by the procedures and provisions stipulated in all applicable export laws and regulations, including without limitation the US Export Administration Regulations and the Foreign Exchange and Foreign Trade Act.
- 13) This document, in part or in whole, may not be reprinted or reproduced without prior consent of ROHM.



Thank you for your accessing to ROHM product informations.  
More detail product informations and catalogs are available, please contact us.

## ROHM Customer Support System

<http://www.rohm.com/contact/>