

Linear Regulator Series BDxxFA1A

PCB Layout

The basic terminal configuration of a linear regulator IC consists of four parts: input, output, GND, and feedback* (* is for the output voltage adjustable type only). The only external components are input/output capacitors and a feedback resistor. Even a linear regulator that facilitates power generation will not operate correctly if its layout is improperly written. Therefore, PCB layout is as important as circuit design. The primary problems likely to occur due to improper layout are ineffective regulation and instability. Adoption of a proper layout will prevent the occurrence of these problems.

A VCC pin, also used as a power supply for internal amplifiers, must shunt the signal to ground via a low ESR ceramic capacitor (A). It is recommended to place a bypass capacitor within 5 mm of the VCC pin on the same surface. Although it is also preferable to place the input bulk capacitor on the same surface, it may have to be placed on the underside due to lack of layout space or for other reason. If this happens, the requirements of the bypass capacitor must be satisfied (B).

Since an output capacitor is one of the phase compensation components of an error amplifier, connect it to ground and locate 2 cm or less from the IC (C). To further add bulk capacity, the bulk capacitor can be placed farther away.

When using an electrolytic capacitor, its service-life may be shortened by high temperature. To restrain heat conductivity from the IC, it is recommended to connect the electrolytic capacitor using the minimum wiring width for the allowable current.

It is recommended to lay out VIN, VO and GND wirings on the same surface as the IC. Be sure to set the wiring width more than the current capacity of copper wiring (F). If these wiring paths have to be placed on another layer

because of limited PCB area, provide multiple vias to ensure current capacity.

For an IC provided with an exposed pad (underside heatsink pad), it is required to solder the pad to ground. Also, for an operation subject to large power loss, the upper layer ground section must have a sufficient heatsink area. If sufficient area cannot be secured on the upper layer, use the ground plane of the inner layer or underside and provide multiple vias directly under or near the IC so as to improve heatsink performance (G).

It is recommended to connect N.C. pins to ground for the purpose of securing a heatsink area.

Figure List

SOT89-3K

With Diode: Figures 1 to 3

Without Diode: Figures 4 to 6

SSOP5

With Diode: Figure 7 to 9

Without Diode: Figures 10 to 12

SOT89-3K (with Diode)

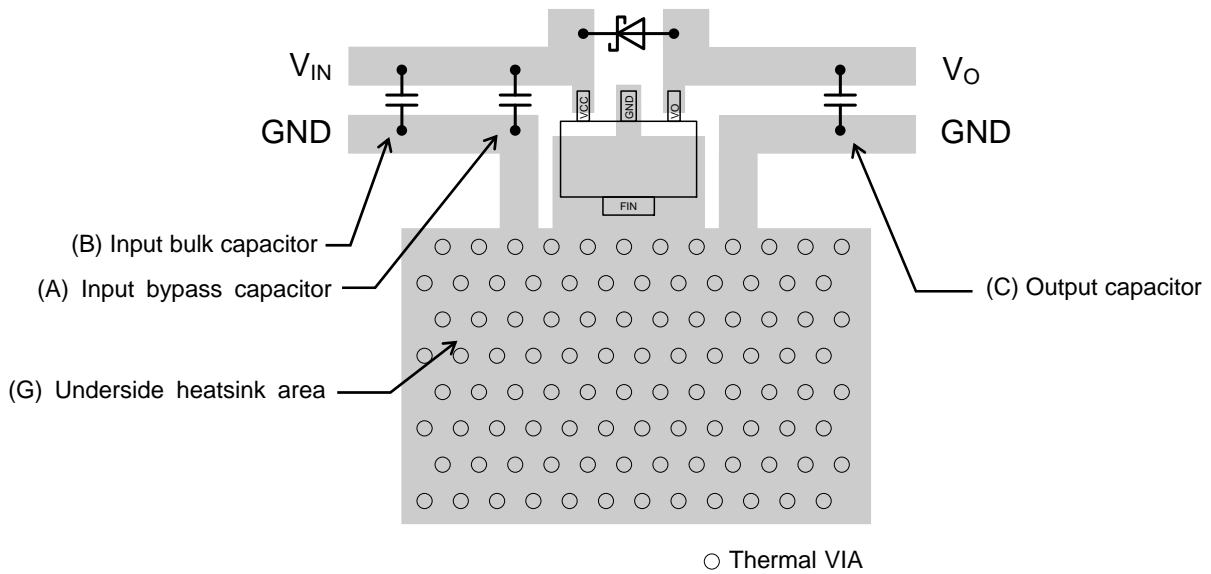

Figure 1. PCB Layout (SOT89-3K Package)

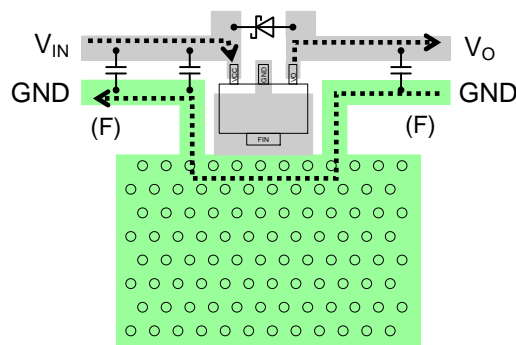

Figure 2. Large Current Ground Wiring

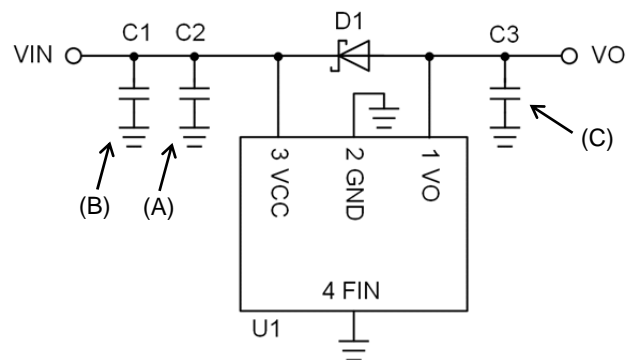

Figure 3. Circuit Diagram

SOT89-3K (without Diode)

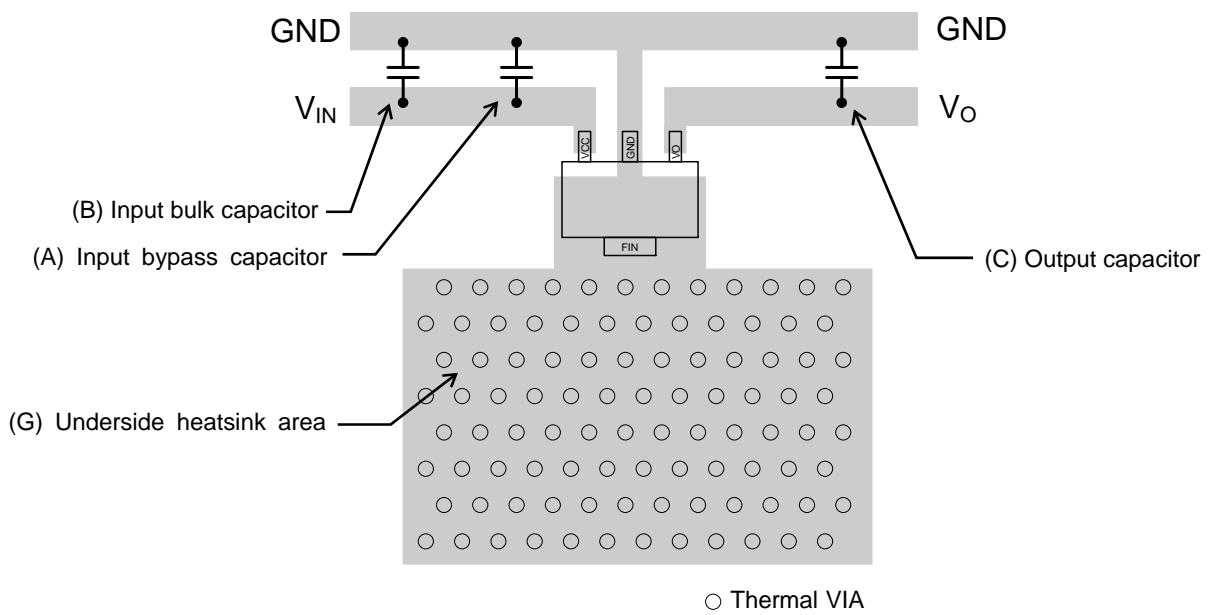

Figure 4. PCB Layout (SOT89-3K Package)

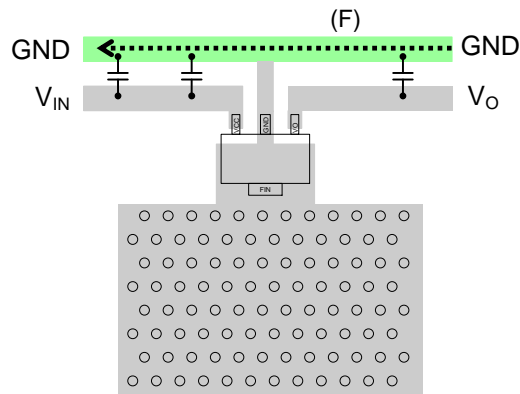

Figure 5. Large Current Ground Wiring

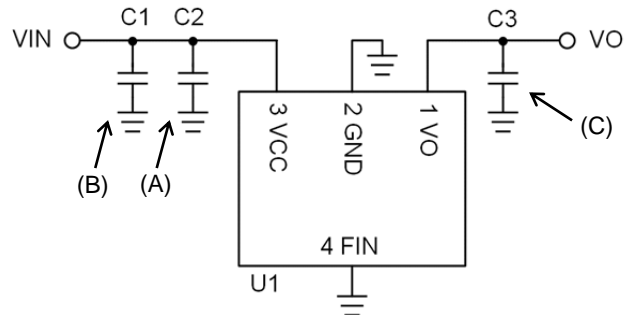

Figure 6. Circuit Diagram

SSOP5 (with Diode)

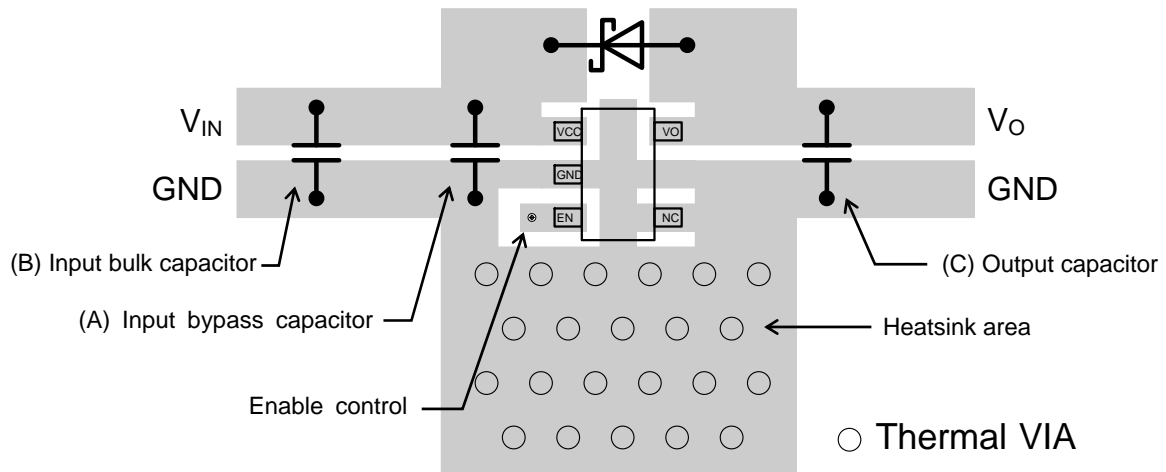

Figure 7. PCB Layout (SSOP5 Package)

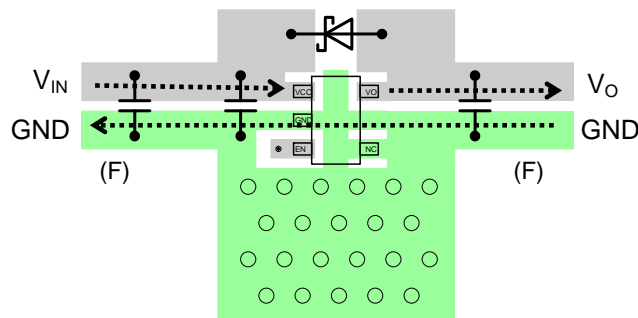

Figure 8. Large Current Ground Wiring

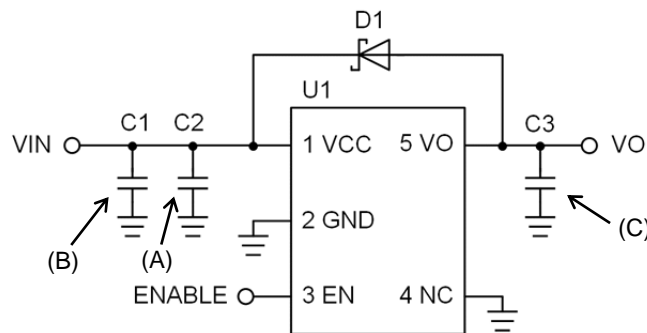

Figure 9. Circuit Diagram

SSOP5 (without Diode)

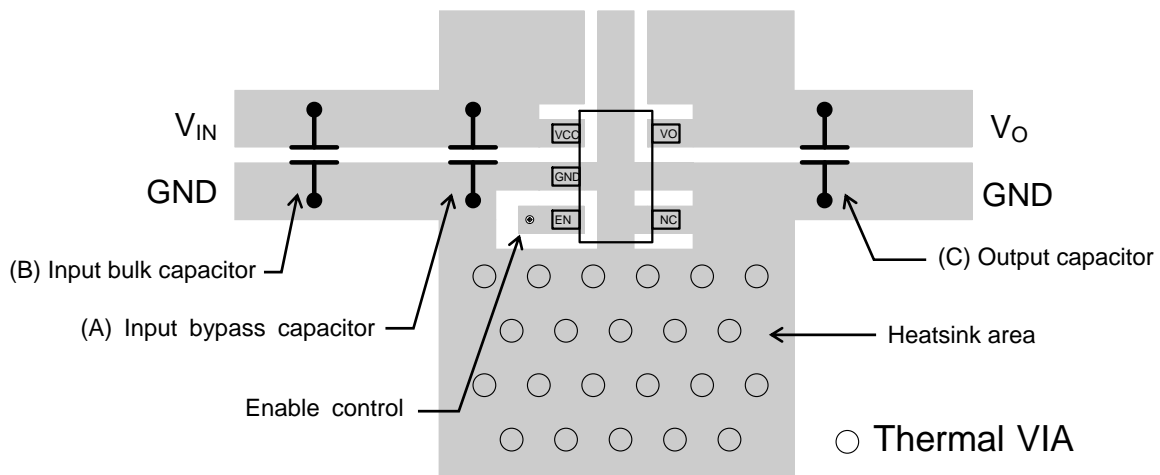

Figure 10. PCB Layout (SSOP5 Package)

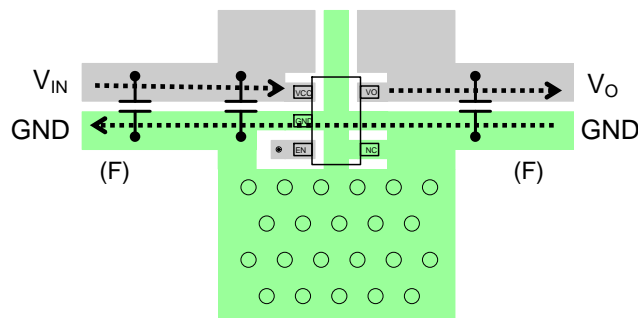

Figure 11. Large Current Ground Wiring

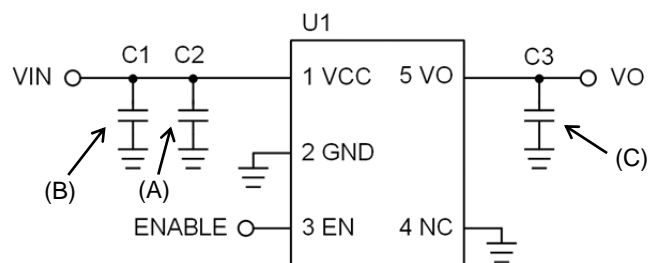

Figure 12. Circuit Diagram

Notes

- 1) The information contained herein is subject to change without notice.
- 2) Before you use our Products, please contact our sales representative and verify the latest specifications :
- 3) Although ROHM is continuously working to improve product reliability and quality, semiconductors can break down and malfunction due to various factors.
Therefore, in order to prevent personal injury or fire arising from failure, please take safety measures such as complying with the derating characteristics, implementing redundant and fire prevention designs, and utilizing backups and fail-safe procedures. ROHM shall have no responsibility for any damages arising out of the use of our Products beyond the rating specified by ROHM.
- 4) Examples of application circuits, circuit constants and any other information contained herein are provided only to illustrate the standard usage and operations of the Products. The peripheral conditions must be taken into account when designing circuits for mass production.
- 5) The technical information specified herein is intended only to show the typical functions of and examples of application circuits for the Products. ROHM does not grant you, explicitly or implicitly, any license to use or exercise intellectual property or other rights held by ROHM or any other parties. ROHM shall have no responsibility whatsoever for any dispute arising out of the use of such technical information.
- 6) The Products are intended for use in general electronic equipment (i.e. AV/OA devices, communication, consumer systems, gaming/entertainment sets) as well as the applications indicated in this document.
- 7) The Products specified in this document are not designed to be radiation tolerant.
- 8) For use of our Products in applications requiring a high degree of reliability (as exemplified below), please contact and consult with a ROHM representative : transportation equipment (i.e. cars, ships, trains), primary communication equipment, traffic lights, fire/crime prevention, safety equipment, medical systems, servers, solar cells, and power transmission systems.
- 9) Do not use our Products in applications requiring extremely high reliability, such as aerospace equipment, nuclear power control systems, and submarine repeaters.
- 10) ROHM shall have no responsibility for any damages or injury arising from non-compliance with the recommended usage conditions and specifications contained herein.
- 11) ROHM has used reasonable care to ensure the accuracy of the information contained in this document. However, ROHM does not warrant that such information is error-free, and ROHM shall have no responsibility for any damages arising from any inaccuracy or misprint of such information.
- 12) Please use the Products in accordance with any applicable environmental laws and regulations, such as the RoHS Directive. For more details, including RoHS compatibility, please contact a ROHM sales office. ROHM shall have no responsibility for any damages or losses resulting from non-compliance with any applicable laws or regulations.
- 13) When providing our Products and technologies contained in this document to other countries, you must abide by the procedures and provisions stipulated in all applicable export laws and regulations, including without limitation the US Export Administration Regulations and the Foreign Exchange and Foreign Trade Act.
- 14) This document, in part or in whole, may not be reprinted or reproduced without prior consent of ROHM.



Thank you for your accessing to ROHM product informations.
More detail product informations and catalogs are available, please contact us.

ROHM Customer Support System

<http://www.rohm.com/contact/>