

Maximizes the high-speed switching performance of GaN

# Ultra-high-speed Gate Driver IC for GaN HEMT Drive

(Single-channel)

BD2311NVX-LB

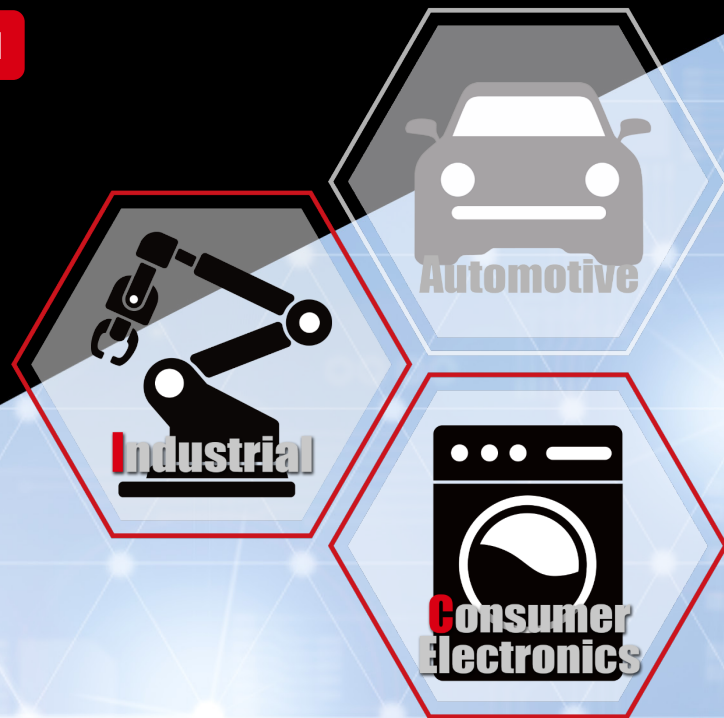

The **BD2311NVX-LB** is a single-channel gate driver IC optimized for driving GaN HEMTs. In addition to supporting narrow pulse high-speed switching required for GaN HEMTs, a built-in original overshoot suppression circuit ensures GaN reliability.

## Features

- **Proprietary drive system suppresses gate voltage overshoot**  
Effective for general GaN HEMTs (6V gate breakdown voltage)
- **Capable of generating narrow pulses for high-speed gate drive**  
Drives GaN devices with ultra-fast switching (pulse width on the order of nanoseconds)
- **Combining with GaN HEMTs enables high-speed drive of target devices**  
e.g. Narrow pulse driving of laser diodes (LiDAR)



**SSON06RX2020**

2.0×2.0×0.6mm (Max)

# Suppresses Gate Voltage Overshoot (Detrimental to Gan HEMTs)

## Gate Voltage Waveform Comparison (Gate Resistor : 0Ω)

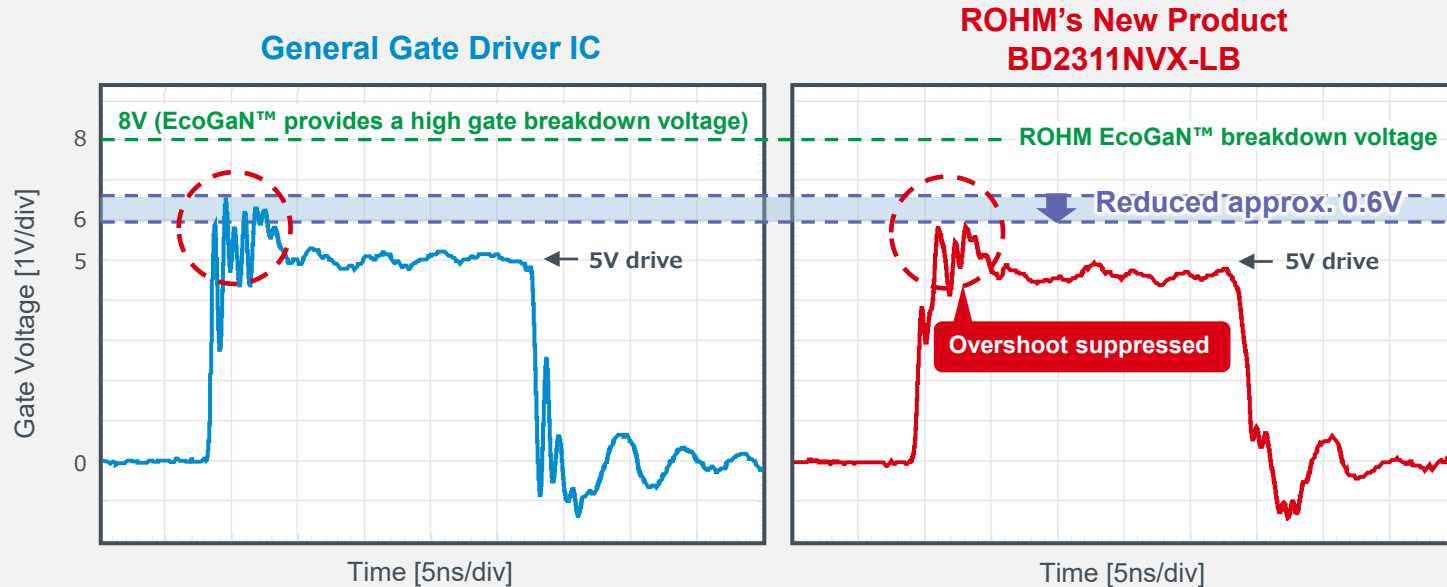

Compatible with general GaN HEMTs

Combining with ROHM's EcoGaN™ (8V gate breakdown voltage) provides double the reliability

EcoGaN™ is a trademark or registered trademark of ROHM Co., Ltd.

## BD2311NVX-LB Minimum Gate Input Pulse Width Characteristics

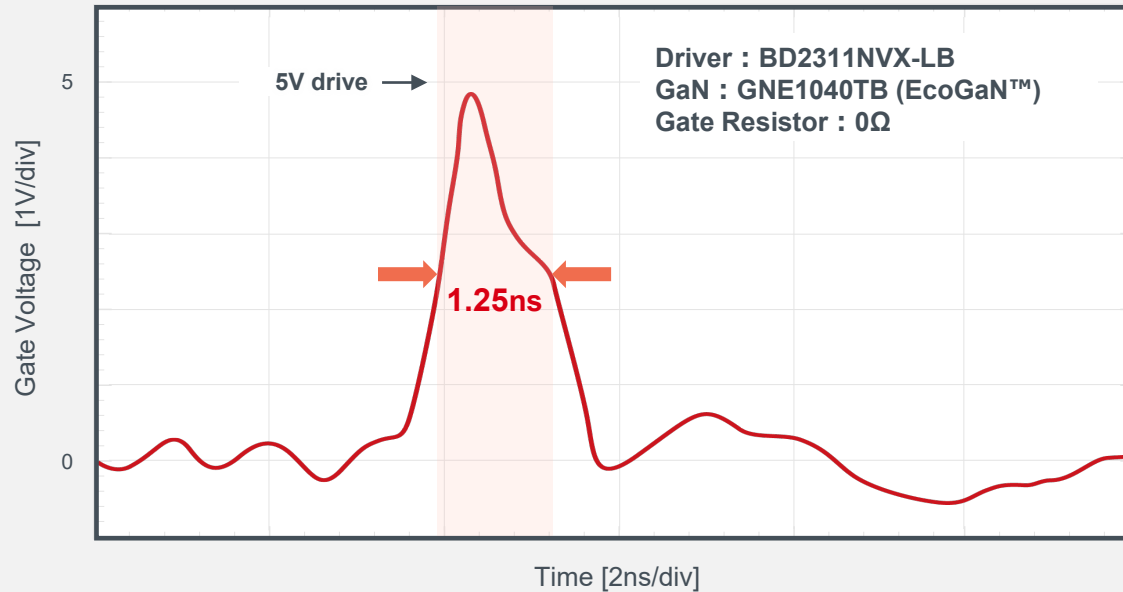

**Capable of driving high-speed switching devices in nanoseconds**

EcoGaN™ is a trademark or registered trademark of ROHM Co., Ltd.

# Application Example that Leverages the Features of Gate Driver IC (BD2311NVX) + GaN HEMT

## Narrow pulse driving (lighting) of laser diodes

# LiDAR

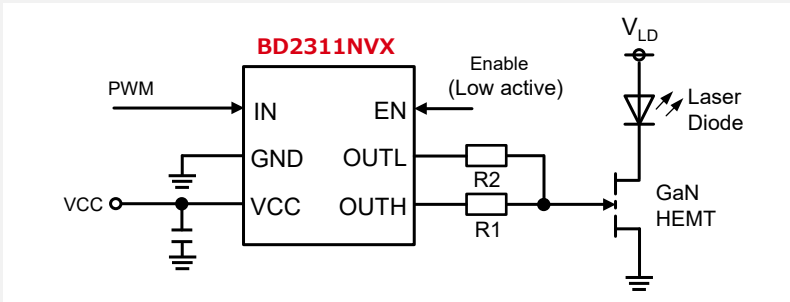

Sharp narrow pulse width enables high resolution



### ROHM's Product: BD2311NVX series + EcoGaN™

Narrow pulse waveform

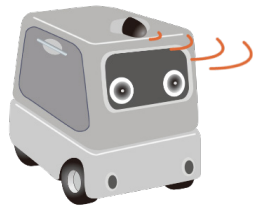



### General Product: Gate Driver + GaN HEMT

Wide pulse waveform



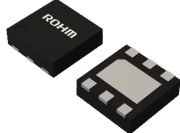

EcoGaN™ is a trademark or registered trademark of ROHM Co., Ltd.

# Ultra-High-Speed Gate Driver ICs for GaN HEMT Drive (Single-Channel)

Part No.	Input Side Supply Voltage [V]	Output Current (Typ) [A]	Delay Time		Min Input Pulse Width (Typ) [ns]	Operating Temperature [°C]	Package [mm]	Automotive-Grade AEC-Q100
			Turn ON	Turn OFF				
			(Typ) [ns]					
<b>New</b> <b>BD2311NVX-LB</b>  	4.5 to 5.5	+7/-5	0.65	0.70	1.25	-40 to +125	 <b>SSON06RX2020</b> 2.0×2.0×0.6(Max)	—
☆ <b>BD2311NVX-C</b>								YES

☆ Under Development

Click on the  icon to access the product page and the  icon to view the datasheet on ROHM's website.

## LiDAR Reference Design

### 3 Onboard Products

High Output Laser Diode  
EcoGaN™ High-Speed Drive  
High-Speed Gate Driver



**REFLD002-1**  
Square Wave Circuit

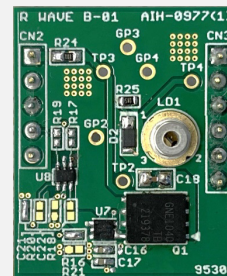

**REFLD002-2**  
Resonant Circuit

### Product Page on ROHM's Website

[REFLD002 Reference Design / Application Evaluation Kit | ROHM Co., Ltd.](#)

EcoGaN™ is a trademark or registered trademark of ROHM Co., Ltd.

## Notice

---

- The information contained in this document is intended to introduce ROHM Group (hereafter referred to as ROHM) products. When using ROHM products, please verify the latest specifications or datasheets before use.
- ROHM does not warrant that the information contained herein is error-free. ROHM shall not be in any way responsible or liable for any damages, expenses, or losses incurred by you or third parties resulting from errors contained in this document.
- The information and data described in this document, including typical application circuits, are examples only and are not intended to guarantee to be free from infringement of third parties intellectual property or other rights. ROHM does not grant any license, express or implied, to implement, use, or exploit any intellectual property or other rights owned or controlled by ROHM or any third parties with respect to the information and data contained herein.
- When exporting ROHM products or technologies described in this document to other countries, you must abide by the procedures and provisions stipulated in all applicable export laws and regulations, such as the Foreign Exchange and Foreign Trade Act and the US Export Administration Regulations, and follow the necessary procedures in accordance with these provisions.
- No part of this document may be reprinted or reproduced in any form by any means without the prior written consent of ROHM.
- The information contained in this document is current as of September 2023 and is subject to change without notice.



**ROHM Co.,Ltd.**

21 Saiin Mizosaki-cho, Ukyo-ku,  
Kyoto 615-8585 Japan

[www.rohm.com](http://www.rohm.com)