

D/A Converters Series

D/A Converters

10 bit 2 channels • 3 channels Type

BD7971xFVM-LB Series

General Description

This product is a rank product for the industrial equipment market. This is the best product for use in these applications.

BD79710FVM-LB and BD79711FVM-LB are 10 bit R-2R-type D/A converters with 2 and 3 channels, respectively. A compact package allows adjacent placement, thereby eliminating deterioration of the D/A converter due to with pattern. A broad power supply voltage range (2.7 V to 5.5 V) is available, providing design flexibility.

Features

- Compact Package Enabling Adjacent Placement
- Built-in Initial Zero Hold Function
- High Speed Output Response Characteristics
- 3-line Serial Interface

Applications

- Industrial Equipment
- Battery Operating Equipment
- Digital Gain Adjustment or Offset Adjustment
- Programmable Voltage Source or Current Source
- Programmable Attenuator

Key Specifications

- Power Source Voltage Range: 2.7 V to 5.5 V
- Current Consumption: 0.7 mA (Typ)
- Differential Non Linearity: ± 0.8 LSB (Max)
- Integral Non Linearity: ± 2.0 LSB (Max)
- Settling Time: 4.5 μ s (Max)
- Max Data Transfer Frequency: 30 MHz (Max)
- Operating Temperature Range: -40 °C to +125 °C

Package

MSOP8

W (Typ) x D (Typ) x H (Max)

2.9 mm x 4.0 mm x 0.9 mm

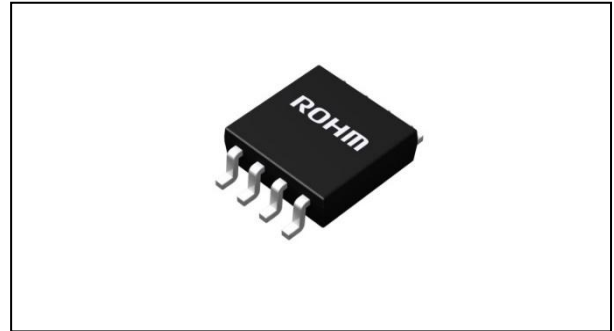

Typical Application Circuits

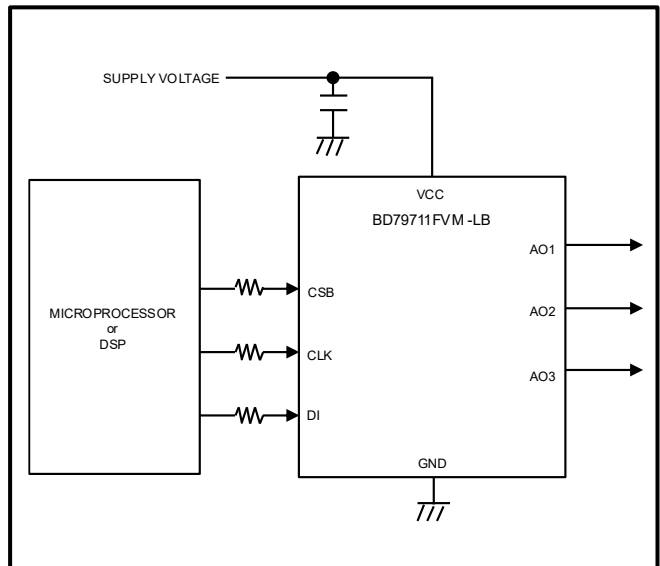
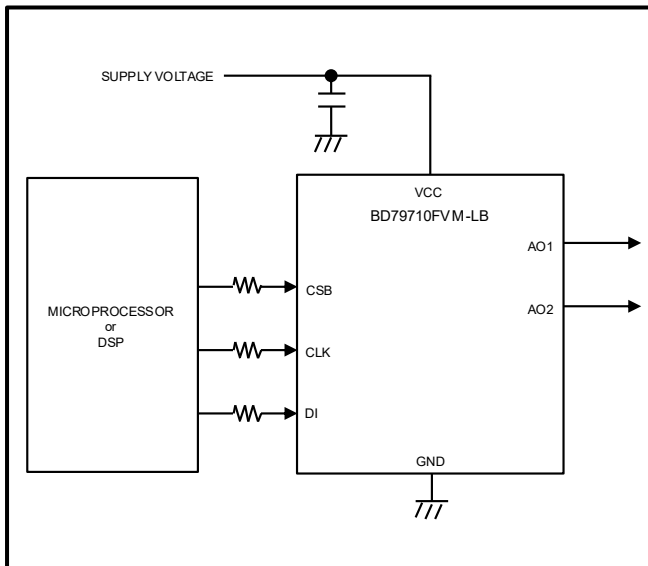

Contents

| | |
|--|----|
| General Description | 1 |
| Features..... | 1 |
| Applications | 1 |
| Key Specifications | 1 |
| Package..... | 1 |
| Typical Application Circuit | 1 |
| Pin Configuration | 3 |
| Pin Descriptions..... | 3 |
| Block Diagram | 3 |
| Absolute Maximum Ratings | 4 |
| Thermal Resistance..... | 4 |
| Recommended Operating Conditions..... | 5 |
| Electrical Characteristics..... | 5 |
| Timing Specifications..... | 6 |
| Typical Performance Curves..... | 7 |
| Power-up Sequence | 12 |
| Communication Format..... | 13 |
| Register Map | 13 |
| Application Example | 15 |
| I/O Equivalence Circuit | 15 |
| Operational Notes..... | 16 |
| Ordering Information..... | 18 |
| Marking Diagram | 18 |
| Physical Dimension and Packing Information | 19 |
| Revision History..... | 20 |

Pin Configurations

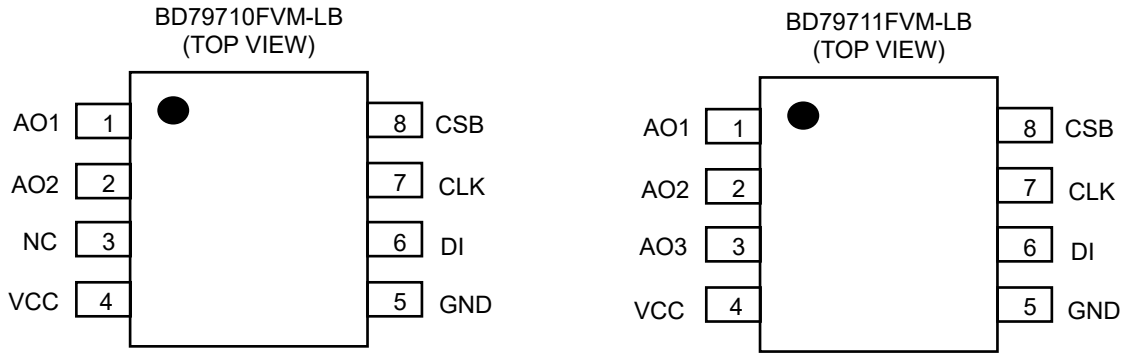

Pin Descriptions

(BD79710FVM-LB)

| Pin No. | Pin Name | Function |
|---------|----------|--------------------------|
| 1 | AO1 | Analog output pin 1. |
| 2 | AO2 | Analog output pin 2. |
| 3 | NC | NC. |
| 4 | VCC | Power supply pin. |
| 5 | GND | Ground pin. |
| 6 | DI | Digital data input pin. |
| 7 | CLK | Digital clock input pin. |
| 8 | CSB | Chip select pin. |

(BD79711FVM-LB)

| Pin No. | Pin Name | Function |
|---------|----------|--------------------------|
| 1 | AO1 | Analog output pin 1. |
| 2 | AO2 | Analog output pin 2. |
| 3 | AO3 | Analog output pin 3. |
| 4 | VCC | Power supply pin. |
| 5 | GND | Ground pin. |
| 6 | DI | Digital data input pin. |
| 7 | CLK | Digital clock input pin. |
| 8 | CSB | Chip select pin. |

Block Diagrams

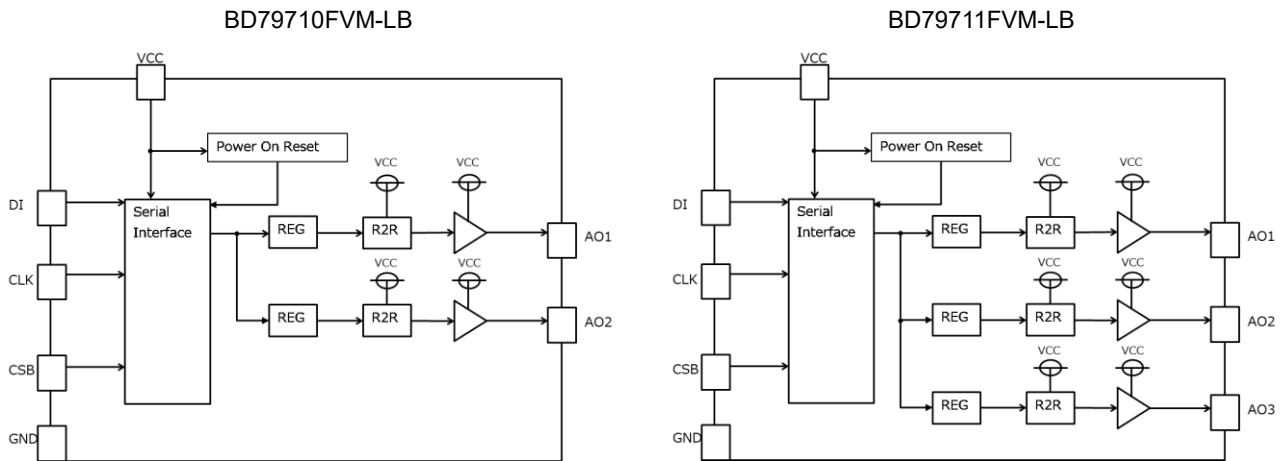

Absolute Maximum Ratings

| Parameter | Symbol | Limit | Unit |
|------------------------------|-------------------|------------------------------|------|
| Supply Voltage | V _{CC} | 7.0 | V |
| Input Voltage | V _{IN} | -0.3 to V _{CC} +0.3 | V |
| Maximum Junction Temperature | T _{Jmax} | 150 | °C |
| Storage Temperature Range | T _{stg} | -55 to +150 | °C |

Caution 1: Operating the IC over the absolute maximum ratings may damage the IC. The damage can either be a short circuit between pins or an open circuit between pins and the internal circuitry. Therefore, it is important to consider circuit protection measures, such as adding a fuse, in case the IC is operated over the absolute maximum ratings.

Caution 2: Should by any chance the maximum junction temperature rating be exceeded the rise in temperature of the chip may result in deterioration of the properties of the chip. In case of exceeding this absolute maximum rating, design a PCB with thermal resistance taken into consideration by increasing board size and copper area so as not to exceed the maximum junction temperature rating.

Thermal Resistance(Note 1)

| Parameter | Symbol | Thermal Resistance (Typ) | | Unit |
|--|-----------------|--------------------------|------------------------|------|
| | | 1s ^(Note 3) | 4s ^(Note 4) | |
| MSOP8 | | | | |
| Junction to Ambient | θ _{JA} | 284.1 | 135.4 | °C/W |
| Junction to Top Characterization Parameter ^(Note 2) | Ψ _{JT} | 21 | 11 | °C/W |

(Note 1) Based on JESD51-2A (Still-Air),

(Note 2) The thermal characterization parameter to report the difference between junction temperature and the temperature at the top center of the outside surface of the component package.

(Note 3) Using a PCB board based on JESD51-3.

(Note 4) Using a PCB board based on JESD51-7.

| Layer Number of Measurement Board | Material | Board Size |
|-----------------------------------|----------|-------------------------------|
| Single | FR-4 | 114.3 mm x 76.2 mm x 1.57 mmt |

| Top | |
|-----------------------|-----------|
| Copper Pattern | Thickness |
| Footprints and Traces | 70 μm |

| Layer Number of Measurement Board | Material | Board Size |
|-----------------------------------|----------|------------------------------|
| 4 Layers | FR-4 | 114.3 mm x 76.2 mm x 1.6 mmt |

| Top | | 2 Internal Layers | | Bottom | |
|-----------------------|-----------|-------------------|-----------|-------------------|-----------|
| Copper Pattern | Thickness | Copper Pattern | Thickness | Copper Pattern | Thickness |
| Footprints and Traces | 70 μm | 74.2 mm x 74.2 mm | 35 μm | 74.2 mm x 74.2 mm | 70 μm |

Recommended Operating Conditions

| Parameter | Symbol | Min | Typ | Max | Unit |
|------------------------|------------|-----|-----|----------|------|
| Supply Voltage | V_{CC} | 2.7 | - | 5.5 | V |
| Input Voltage | V_{IN} | 0 | - | V_{CC} | V |
| Operating Temperature | T_{opr} | -40 | +25 | +125 | °C |
| Serial Clock Frequency | f_{SCLK} | - | 10 | 30 | MHz |
| Load Capacitance Limit | C_L | - | - | 1500 | pF |

Electrical Characteristics

(Unless otherwise specified $V_{CC} = 2.7\text{ V to }5.5\text{ V}$, $T_a = 25\text{ °C}$, $f_{SCLK} = 30\text{ MHz}$)

| Parameter | Symbol | Min | Typ | Max | Unit | Conditions |
|--------------------------------|-----------|-------------|-----------------|-------------|---------------|--|
| <Current Consumption> | | | | | | |
| Power Down Current | I_{PD} | - | 0.3 | - | μA | Power Down Hi-Z, CLK = 0 V, CSB = V_{CC} , DI = V_{CC} |
| Current Consumption | I_{CC} | - | 0.7 | 1.2 | mA | 7800h setting |
| <Logic Interface> | | | | | | |
| L Input Voltage | V_{IL} | GND | - | $0.2V_{CC}$ | V | |
| H Input Voltage | V_{IH} | $0.8V_{CC}$ | - | V_{CC} | V | |
| Input Current | I_{IN} | -10 | - | +10 | μA | |
| <Buffer Amplifier> | | | | | | |
| Zero Scale Output Voltage | V_{ZSO} | - | 10 | - | mV | $V_{CC} = 5\text{ V}$, $I_{OH} = 1\text{ mA}$ |
| Full Scale Output Voltage | V_{FSO} | - | $V_{CC} - 0.05$ | - | V | $V_{CC} = 5\text{ V}$, $I_{OL} = 1\text{ mA}$ |
| <D/A Converter Precision> | | | | | | |
| Differential Non Linearity | DNL | -0.8 | - | +0.8 | LSB | Input range is 00Fh to 3F0h |
| Integral Non Linearity | INL | -2.0 | - | +2.0 | LSB | Input range is 00Fh to 3F0h |
| Power On Reset Release Voltage | V_{POR} | - | 1.2 | - | V | |

Timing Specifications

(Unless otherwise specified $V_{CC} = 2.7\text{ V to }5.5\text{ V}$, $T_a = 25\text{ }^\circ\text{C}$, $f_{SCLK} = 30\text{ MHz}$)

| Parameter | Symbol | Min | Typ | Max | Unit | Conditions |
|--------------------------|------------|-----|-----|-----|---------------|--|
| CLK L Level Time | t_{CLKL} | 10 | - | - | ns | |
| CLK H Level Time | t_{CLKH} | 10 | - | - | ns | |
| DI Setup Time | t_{sDI} | 3.5 | - | - | ns | |
| DI Hold Time | t_{hDI} | 3.5 | - | - | ns | |
| CSB Setup Time | t_{sCSB} | 10 | - | - | ns | |
| CSB Hold Time | t_{hCSB} | 10 | - | - | ns | |
| CSB H Level Time | t_{CSBH} | 10 | - | - | ns | |
| D/A Output Settling Time | t_{OUT} | - | - | 4.5 | μs | $C_L = 200\text{ pF}$, $R_L = 2\text{ k}\Omega$ Set-up Time from 100h to 300h |

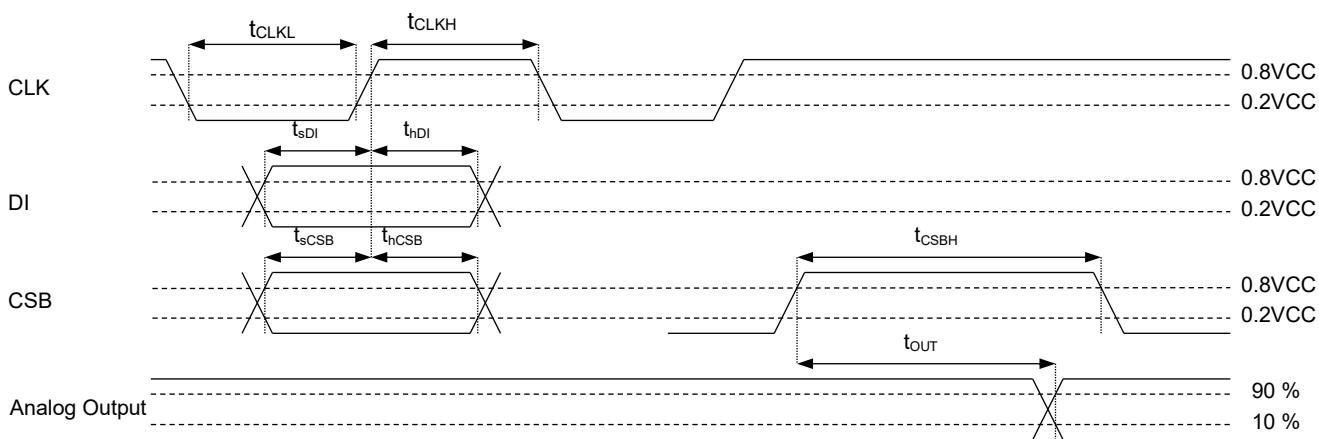

Figure 1. 3-line Serial Bus and Analog Output Timing Chart

Typical Performance Curves

(Reference Data)

Unless otherwise specified $V_{CC} = 3\text{ V}$, $T_a = 25\text{ }^\circ\text{C}$, $f_{SCLK} = 30\text{ MHz}$

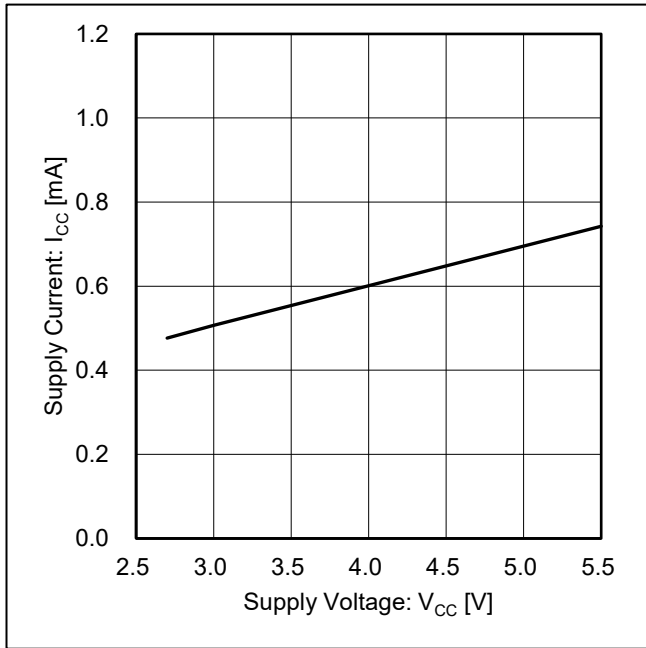

Figure 2. Supply Current vs Supply Voltage (VCC Current Consumption)

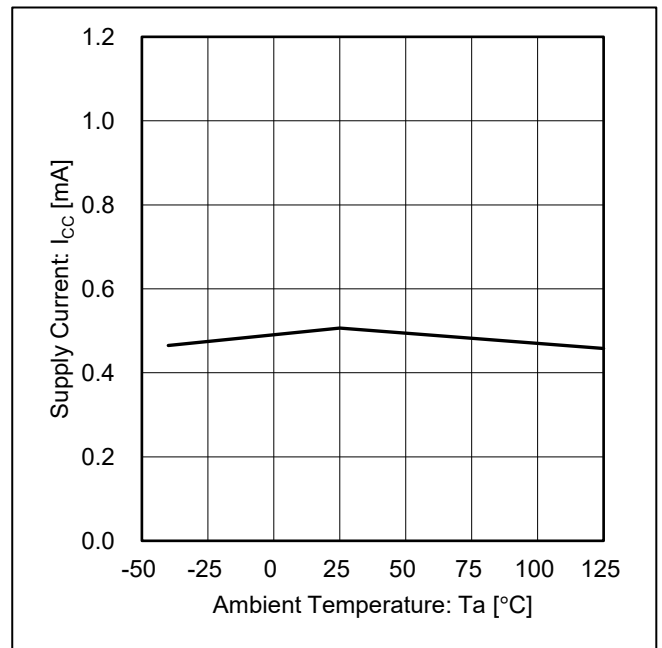

Figure 3. Supply Current vs Ambient Temperature (VCC Current Consumption)

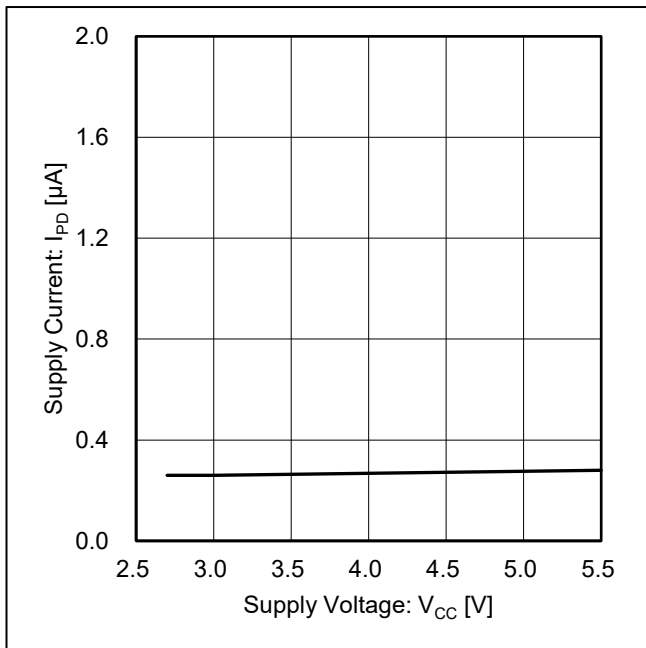

Figure 4. Supply Current vs Supply Voltage (Power Down Current)

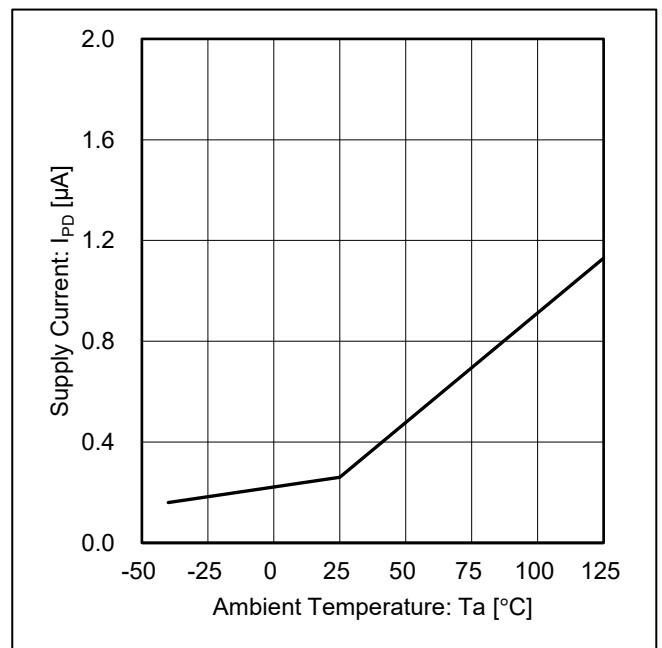

Figure 5. Supply Current vs Ambient Temperature (Power Down Current)

Typical Performance Curves – continued

(Reference Data)

Unless otherwise specified $V_{CC} = 3\text{ V}$, $T_a = 25\text{ }^\circ\text{C}$, $f_{SCLK} = 30\text{ MHz}$

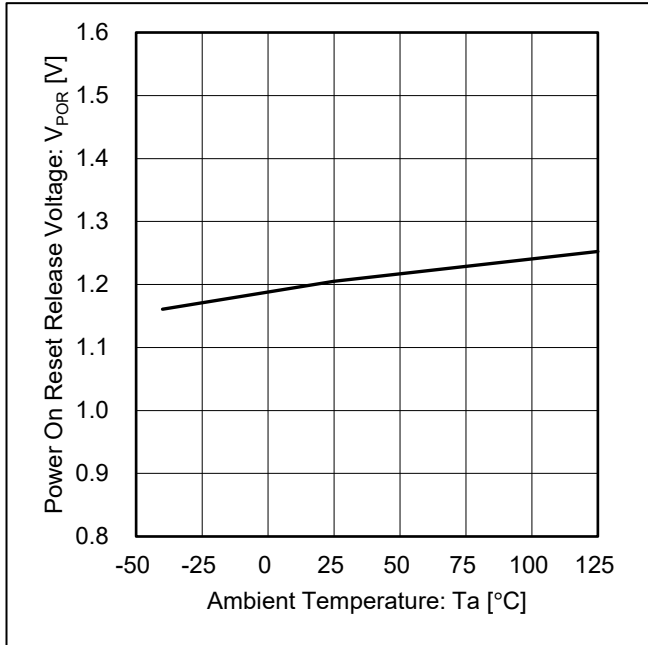

Figure 6. Power On Reset Release Voltage vs Ambient Temperature

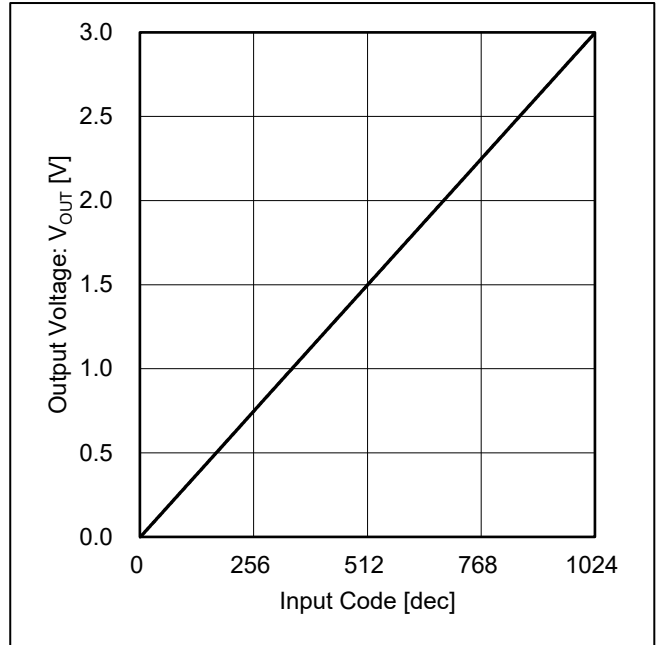

Figure 7. Output Voltage vs Input Code

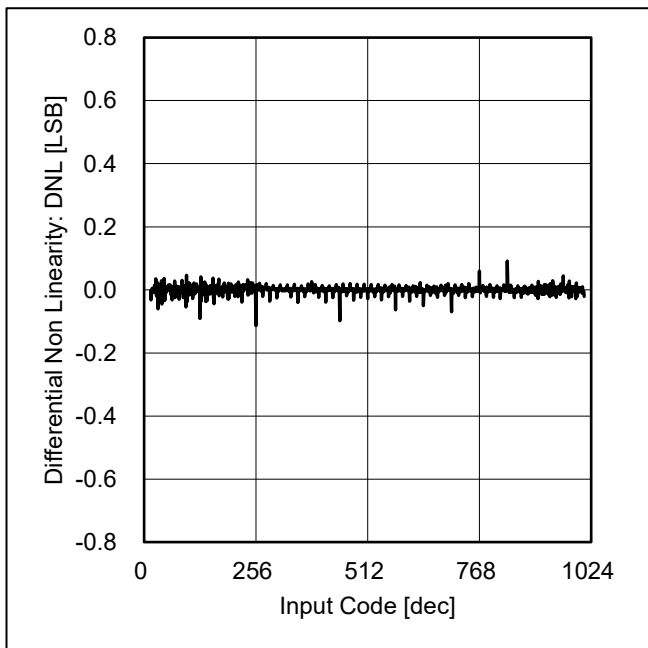

Figure 8. Differential Non Linearity vs Input Code

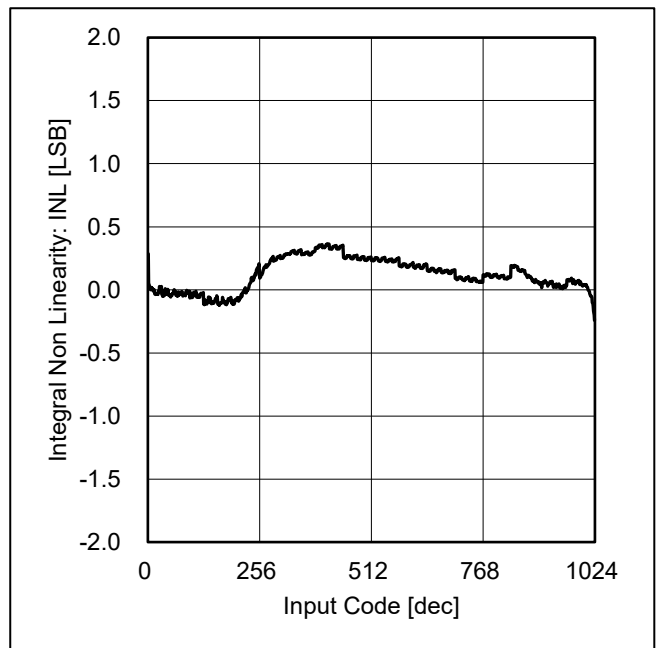

Figure 9. Integral Non Linearity vs Input Code

Typical Performance Curves – continued

(Reference Data)

Unless otherwise specified $V_{CC} = 3\text{ V}$, $T_a = 25\text{ }^\circ\text{C}$, $f_{SCLK} = 30\text{ MHz}$

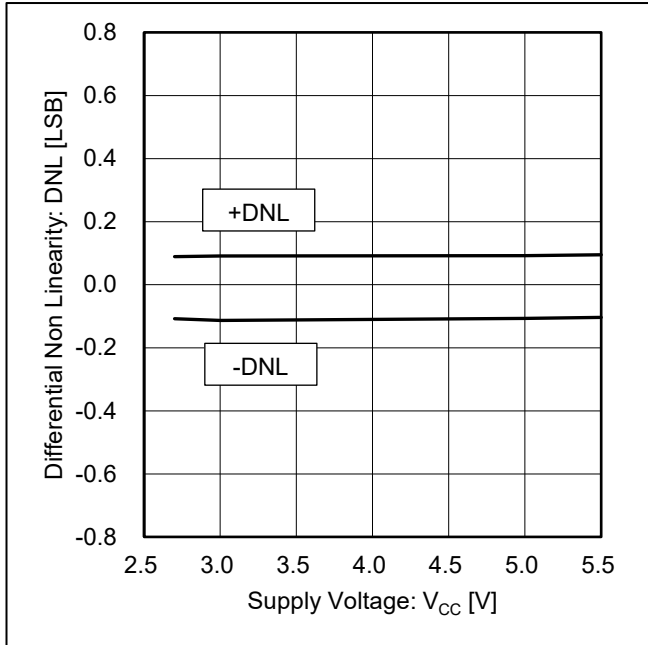

Figure 10. Differential Non Linearity vs Supply Voltage

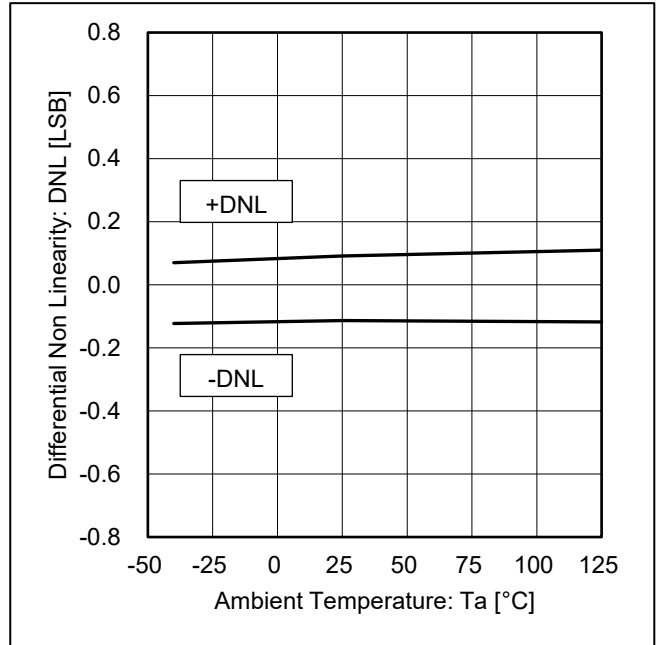

Figure 11. Differential Non Linearity vs Ambient Temperature

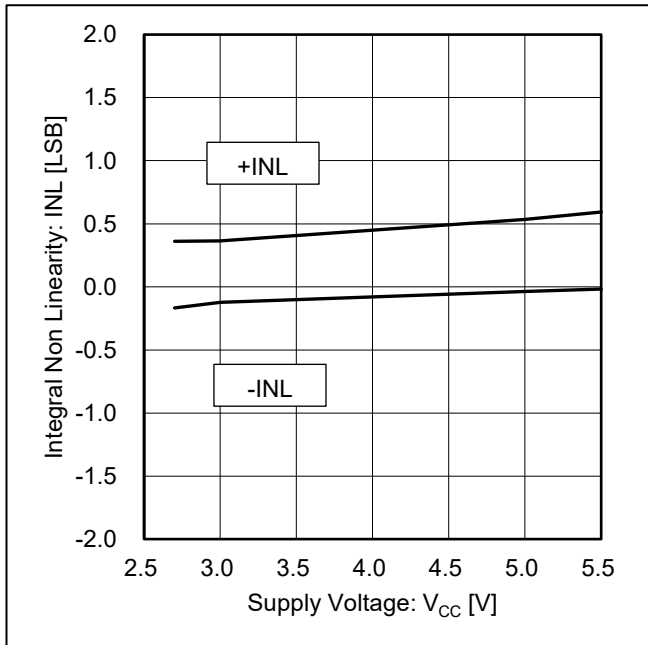

Figure 12. Integral Non Linearity vs Supply Voltage

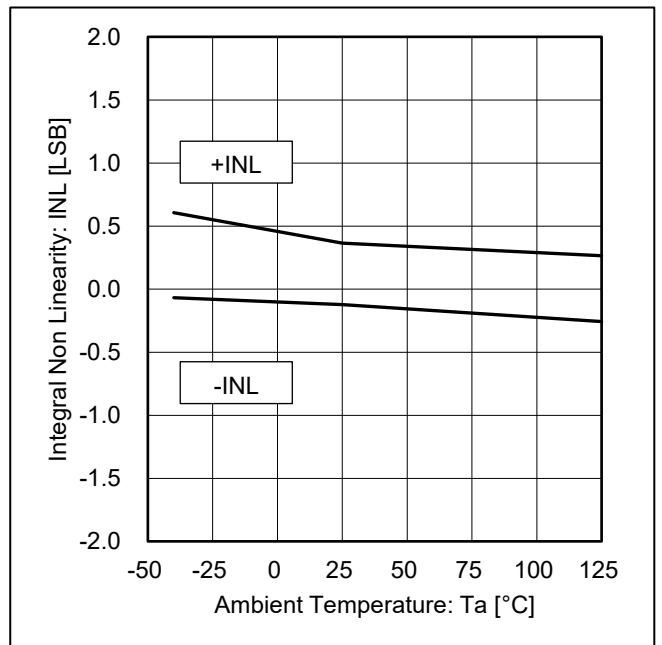

Figure 13. Integral Non Linearity vs Ambient Temperature

Typical Performance Curves – continued

(Reference Data)

Unless otherwise specified $V_{CC} = 3\text{ V}$, $T_a = 25\text{ }^\circ\text{C}$, $f_{SCLK} = 30\text{ MHz}$

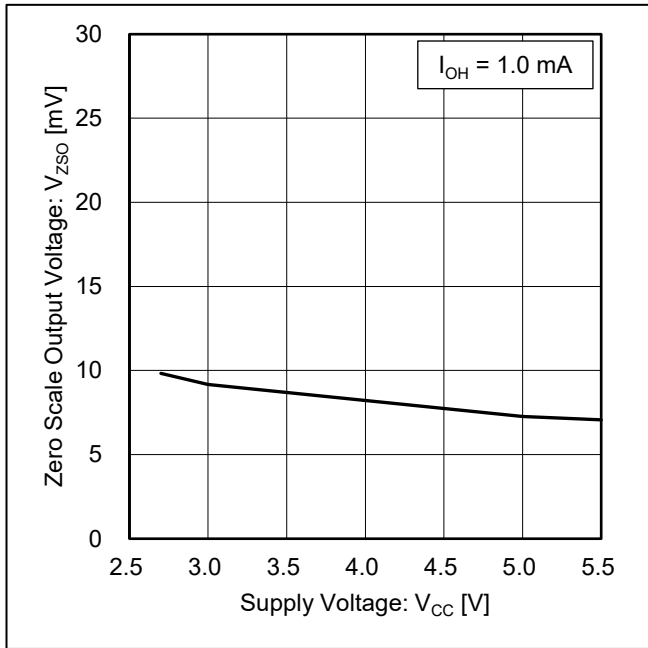

Figure 14. Zero Scale Output Voltage vs Supply Voltage

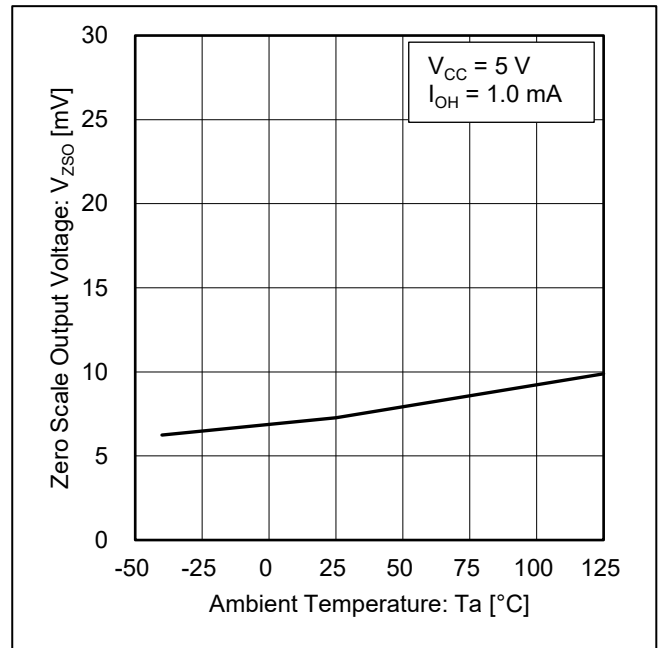

Figure 15. Zero Scale Output Voltage vs Ambient Temperature

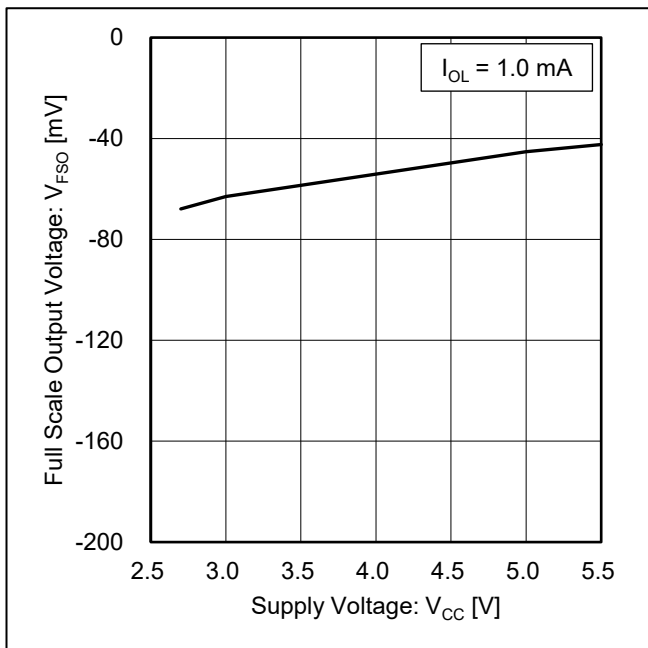

Figure 16. Full Scale Output Voltage vs Supply Voltage

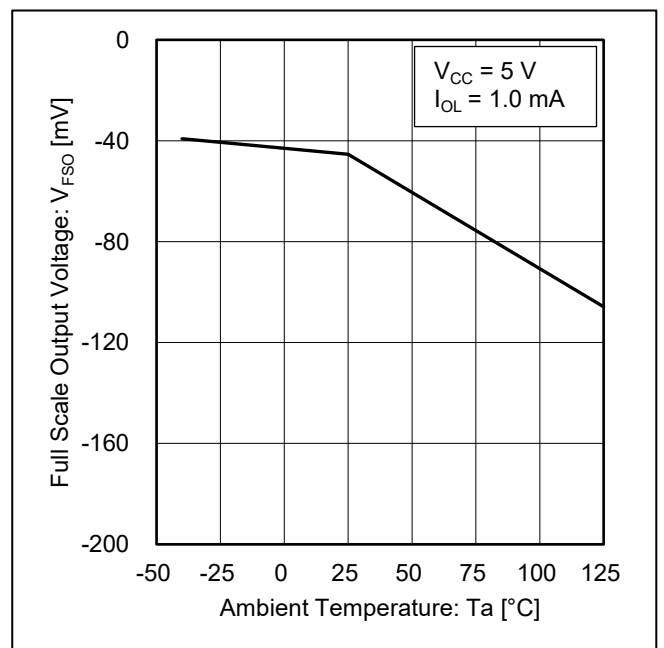

Figure 17. Full Scale Output Voltage vs Ambient Temperature

Typical Performance Curves – continued

(Reference Data)

Unless otherwise specified $V_{CC} = 3\text{ V}$, $T_a = 25\text{ }^\circ\text{C}$, $f_{SCLK} = 30\text{ MHz}$

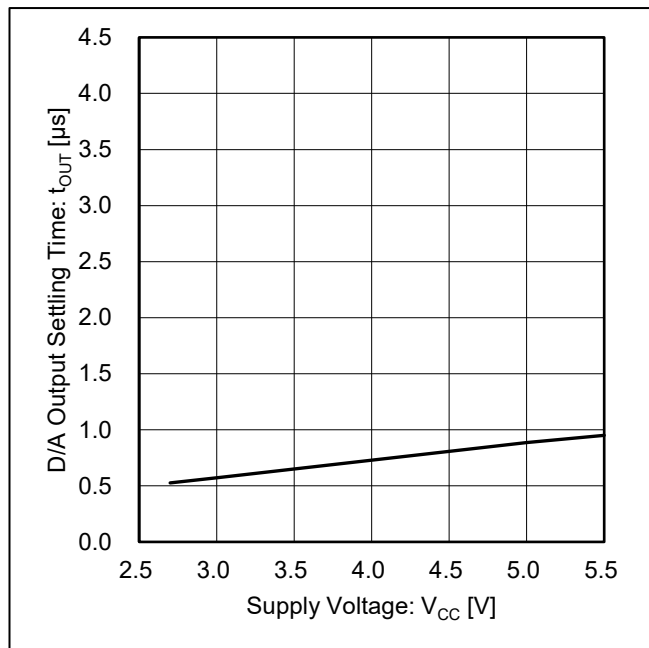

Figure 18. D/A Output Settling Time vs Supply Voltage

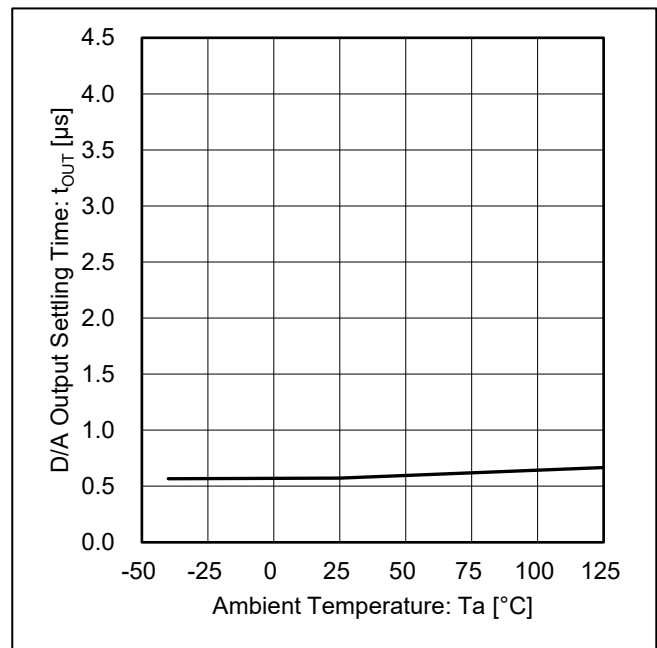

Figure 19. D/A Output Settling Time vs Ambient Temperature

Power-up Sequence

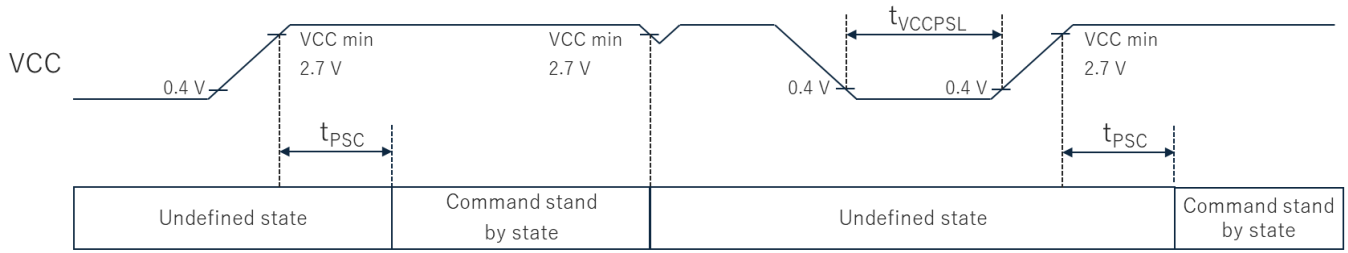

Figure 20. Power-up Timing Chart

(Unless otherwise specified Ta = 25 °C)

| Parameter | Symbol | Min | Typ | Max | Unit |
|--|---------------------|-----|-----|-----|------|
| VCC off time | t _{VCCPSL} | 1 | - | - | ms |
| SPI command available time from Power-up | t _{PSC} | 0.1 | - | - | ms |

After power-on, commands must be issued only after the duration of t_{PSC} has elapsed.
 If the VCC supply voltage drops below the recommended operating range, the IC may enter an undefined state.
 In such cases, power must be turned off completely and then reapplied.
 Before applying VCC, ensure that the VCC voltage remains below 0.4 V for at least the duration of t_{VCCPSL}.

Communication Format

The Serial Control Interface is 3-line 16 bit serial interface (MSB first).
 DI data is read every rising edge of the CLK.
 Last 16 bits of data are latched when CSB goes HIGH.

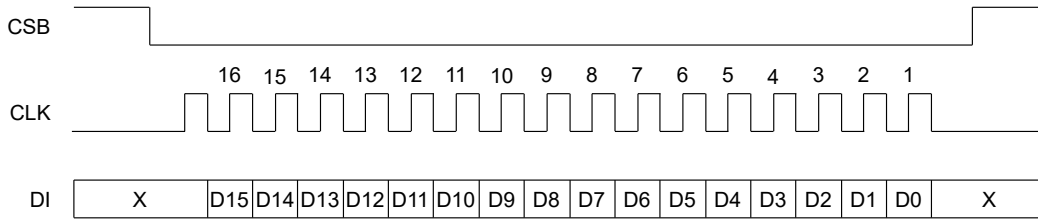

Figure 21. Communication Format

Register Map (Note 5)

Channel setting

| D15 | D14 | D13 | D12 | D11 to D2 | D1 | D0 | BD79710FVM-LB | BD79711FVM-LB |
|-----|-----|-----|-----|----------------|----|----|--------------------------------|--------------------------------|
| 0 | 0 | 0 | 0 | 00_0000_0000 | 0 | 0 | Power Down 100 kΩ | Power Down 100 kΩ |
| 0 | 0 | 0 | 1 | D/A DATA [9:0] | 0 | 0 | AO1 Data Setting and Output | AO1 Data Setting and Output |
| 0 | 0 | 1 | 0 | D/A DATA [9:0] | 0 | 0 | AO2 Data Setting and Output | AO2 Data Setting and Output |
| 0 | 0 | 1 | 1 | D/A DATA [9:0] | 0 | 0 | Not used | AO3 Data Setting and Output |
| 0 | 1 | 0 | 0 | D/A DATA [9:0] | 0 | 0 | Not used | Not used |
| 0 | 1 | 0 | 1 | D/A DATA [9:0] | 0 | 0 | Not used | Not used |
| 0 | 1 | 1 | 0 | D/A DATA [9:0] | 0 | 0 | Not used | Not used |
| 0 | 1 | 1 | 1 | D/A DATA [9:0] | 0 | 0 | All Channel Setting and Output | All Channel Setting and Output |
| 1 | 0 | 0 | 0 | 00_0000_0000 | 0 | 0 | Power Down 2.5 kΩ | Power Down 2.5 kΩ |
| 1 | 0 | 0 | 1 | D/A DATA [9:0] | 0 | 0 | AO1 Data Setting Only | AO1 Data Setting Only |
| 1 | 0 | 1 | 0 | D/A DATA [9:0] | 0 | 0 | AO2 Data Setting Only | AO2 Data Setting Only |
| 1 | 0 | 1 | 1 | D/A DATA [9:0] | 0 | 0 | Not used | AO3 Data Setting Only |
| 1 | 1 | 0 | 0 | D/A DATA [9:0] | 0 | 0 | Not used | Not used |
| 1 | 1 | 0 | 1 | D/A DATA [9:0] | 0 | 0 | Not used | Not used |
| 1 | 1 | 1 | 0 | D/A DATA [9:0] | 0 | 0 | Not used | Not used |
| 1 | 1 | 1 | 1 | 00_0000_0000 | 0 | 0 | Power Down Hi-Z | Power Down Hi-Z |

Data Setting

| D/A DATA [9:0] | | | | | | | | | | Setting |
|----------------|-----|----|----|----|----|----|----|----|----|------------------------|
| D11 | D10 | D9 | D8 | D7 | D6 | D5 | D4 | D3 | D2 | |
| 0 | 0 | 0 | 0 | 0 | 0 | 0 | 0 | 0 | 0 | GND |
| 0 | 0 | 0 | 0 | 0 | 0 | 0 | 0 | 0 | 1 | (Vcc - GND) /1024x1 |
| 0 | 0 | 0 | 0 | 0 | 0 | 0 | 0 | 1 | 0 | (Vcc - GND) /1024x2 |
| 0 | 0 | 0 | 0 | 0 | 0 | 0 | 0 | 1 | 1 | (Vcc - GND) /1024x3 |
| 0 | 0 | 0 | 0 | 0 | 0 | 0 | 1 | 0 | 0 | (Vcc - GND) /1024x4 |
| ⋮ | | | | | | | | | | |
| 1 | 1 | 1 | 1 | 1 | 1 | 1 | 1 | 1 | 0 | (Vcc - GND) /1024x1022 |
| 1 | 1 | 1 | 1 | 1 | 1 | 1 | 1 | 1 | 1 | (Vcc - GND) /1024x1023 |

(Note 5) Do not write '1' to the fields in which value is '0' in above table.

Resister Map – continued

BD79710FVM-LB, BD79711FVM-LB common
(0000h, 8000h, F000h) Power Down Enable

| | |
|--------------------------|---|
| 0000h, Power Down 100 kΩ | All channel are power down mode. Output is 100 kΩ pulldown. |
| 8000h, Power Down 2.5 kΩ | All channel are power down mode. Output is 2.5 kΩ pulldown. |
| F000h, Power Down Hi-Z | All channel are power down mode. Output is Hi-Z state. |

Default value 0x8000

BD79710FVM-LB

(1xxxh to 7xxxh) DAC Output

| | |
|---------------------------|--|
| 1xxxh, AO1 Data Output | Output AO1 with setting data from D11 to D2. |
| 2xxxh, AO2 Data Output | Output AO2 with setting data from D11 to D2. |
| 3xxxh, Not used | Not used |
| 4xxxh, Not used | Not used |
| 5xxxh, Not used | Not used |
| 6xxxh, Not used | Not used |
| 7xxxh, All Channel Output | Output All channel with setting data from D11 to D2. |

Default value 0x0000

(9xxxh to Exxxh) DAC data set only

| | |
|------------------------------|---|
| 9xxxh, AO1 Data Setting Only | Set AO1 DAC code with setting data from D11 to D2. Output is no changed. |
| Axxxh, AO2 Data Setting Only | Set AO2 DAC code with setting data from D11 to D2. Output is no changed. |
| Bxxxh, Not used | Not used |
| Cxxxh, Not used | Not used |
| Dxxxh, Not used | Not used |
| Exxxh, Not used | Not used |

Default value 0x0000

BD79711FVM-LB

(1xxxh to 7xxxh) DAC Output

| | |
|---------------------------|--|
| 1xxxh, AO1 Data Output | Output AO1 with setting data from D11 to D2. |
| 2xxxh, AO2 Data Output | Output AO2 with setting data from D11 to D2. |
| 3xxxh, AO3 Data Output | Output AO3 with setting data from D11 to D2. |
| 4xxxh, Not used | Not used |
| 5xxxh, Not used | Not used |
| 6xxxh, Not used | Not used |
| 7xxxh, All Channel Output | Output All channel with setting data from D11 to D2. |

Default value 0x0000

(9xxxh to Exxxh) DAC data set only

| | |
|------------------------------|---|
| 9xxxh, AO1 Data Setting Only | Set AO1 DAC code with setting data from D11 to D2. Output is no changed. |
| Axxxh, AO2 Data Setting Only | Set AO2 DAC code with setting data from D11 to D2. Output is no changed. |
| Bxxxh, AO3 Data Setting Only | Set AO3 DAC code with setting data from D11 to D2. Output is no changed. |
| Cxxxh, Not used | Not used |
| Dxxxh, Not used | Not used |
| Exxxh, Not used | Not used |

Default value 0x0000

Resister Map – continued

Example Send Command DAC Output

| | Send Command | Command details | AO1 | AO2 |
|----------|--------------|--------------------|-----------------------------------|-----------------------------------|
| Power On | - | - | Power Down 2.5 kΩ | Power Down 2.5 kΩ |
| Step1 | 7800h | Output All channel | Output (V _{CC} - GND) /2 | Output (V _{CC} - GND) /2 |
| Step2 | 1FFCh | Output AO1 | Output V _{CC} | Output (V _{CC} - GND) /2 |

Example Send Command DAC data set only

| | Send Command | Command details | AO1 | AO2 |
|----------|--------------|--|-----------------------------------|-----------------------------------|
| Power On | - | - | Power Down 2.5 kΩ | Power Down 2.5 kΩ |
| Step1 | 7800h | Output All channel | Output (V _{CC} - GND) /2 | Output (V _{CC} - GND) /2 |
| Step2 | A000h | Set AO2 DAC data Output is no changed | Output (V _{CC} - GND) /2 | Output (V _{CC} - GND) /2 |
| Step3 | 1FFCh | Output AO1 All channel update DAC output | Output V _{CC} | Output GND |

Application Examples

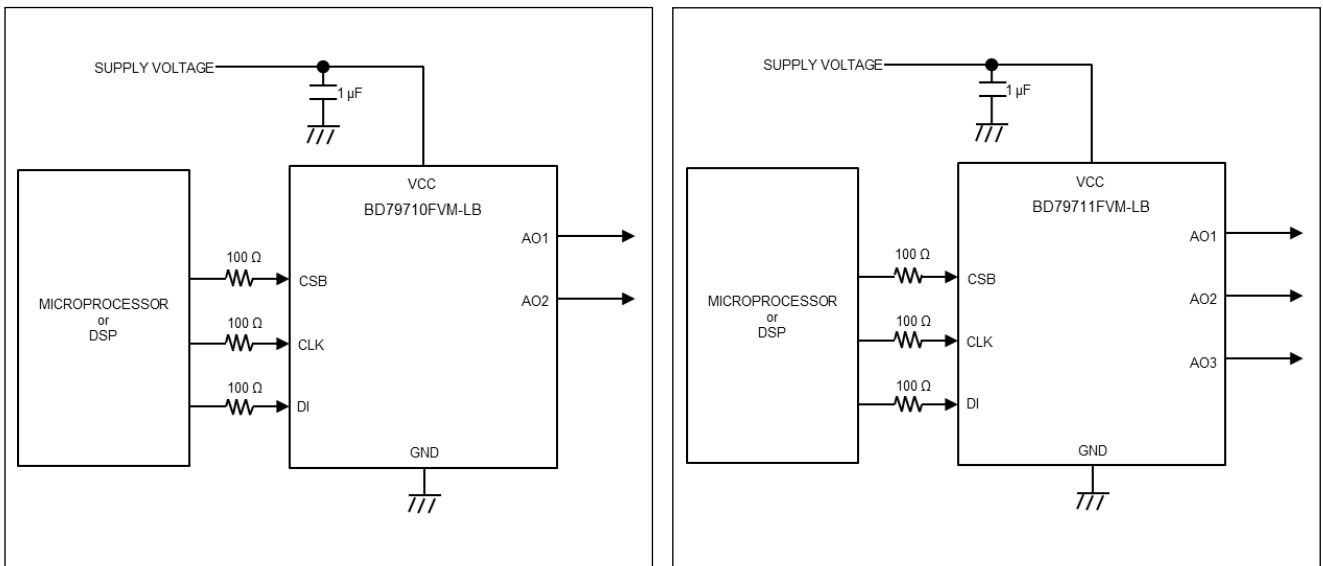

Figure 22. Application Circuit

I/O Equivalence Circuits

| Pin Name | Equivalent Circuit Diagram | Pin Name | Equivalent Circuit Diagram |
|-------------------|----------------------------|------------------|----------------------------|
| AO1 AO2 AO3 | | DI CLK CSB | |

Operational Notes

1. Reverse Connection of Power Supply

Connecting the power supply in reverse polarity can damage the IC. Take precautions against reverse polarity when connecting the power supply, such as mounting an external diode between the power supply and the IC's power supply pins.

2. Power Supply Lines

Design the PCB layout pattern to provide low impedance supply lines. Furthermore, connect a capacitor to ground at all power supply pins. Consider the effect of temperature and aging on the capacitance value when using electrolytic capacitors.

3. Ground Voltage

Ensure that no pins are at a voltage below that of the ground pin at any time, even during transient condition.

4. Ground Wiring Pattern

When using both small-signal and large-current ground traces, the two ground traces should be routed separately but connected to a single ground at the reference point of the application board to avoid fluctuations in the small-signal ground caused by large currents. Also ensure that the ground traces of external components do not cause variations on the ground voltage. The ground lines must be as short and thick as possible to reduce line impedance.

5. Recommended Operating Conditions

The function and operation of the IC are guaranteed within the range specified by the recommended operating conditions. The characteristic values are guaranteed only under the conditions of each item specified by the electrical characteristics.

6. Inrush Current

When power is first supplied to the IC, it is possible that the internal logic may be unstable and inrush current may flow instantaneously due to the internal powering sequence and delays, especially if the IC has more than one power supply. Therefore, give special consideration to power coupling capacitance, power wiring, width of ground wiring, and routing of connections.

7. Testing on Application Boards

When testing the IC on an application board, connecting a capacitor directly to a low-impedance output pin may subject the IC to stress. Always discharge capacitors completely after each process or step. The IC's power supply should always be turned off completely before connecting or removing it from the test setup during the inspection process. To prevent damage from static discharge, ground the IC during assembly and use similar precautions during transport and storage.

8. Inter-pin Short and Mounting Errors

Ensure that the direction and position are correct when mounting the IC on the PCB. Incorrect mounting may result in damaging the IC. Avoid nearby pins being shorted to each other especially to ground, power supply and output pin. Inter-pin shorts could be due to many reasons such as metal particles, water droplets (in very humid environment) and unintentional solder bridge deposited in between pins during assembly to name a few.

9. Unused Input Pins

Input pins of an IC are often connected to the gate of a MOS transistor. The gate has extremely high impedance and extremely low capacitance. If left unconnected, the electric field from the outside can easily charge it. The small charge acquired in this way is enough to produce a significant effect on the conduction through the transistor and cause unexpected operation of the IC. So unless otherwise specified, unused input pins should be connected to the power supply or ground line.

Operational Notes – continued

10. Regarding the Input Pin of the IC

This monolithic IC contains P+ isolation and P substrate layers between adjacent elements in order to keep them isolated. P-N junctions are formed at the intersection of the P layers with the N layers of other elements, creating a parasitic diode or transistor. For example (refer to figure below):

- When GND > Pin A and GND > Pin B, the P-N junction operates as a parasitic diode.
- When GND > Pin B, the P-N junction operates as a parasitic transistor.

Parasitic diodes inevitably occur in the structure of the IC. The operation of parasitic diodes can result in mutual interference among circuits, operational faults, or physical damage. Therefore, conditions that cause these diodes to operate, such as applying a voltage lower than the GND voltage to an input pin (and thus to the P substrate) should be avoided.

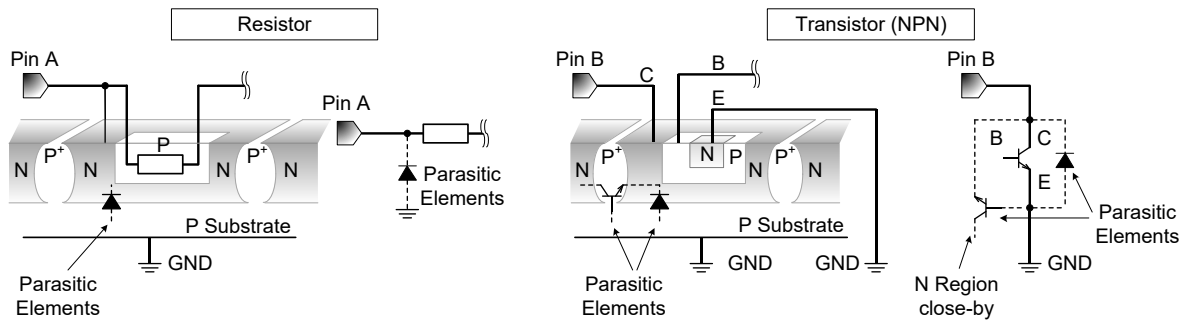
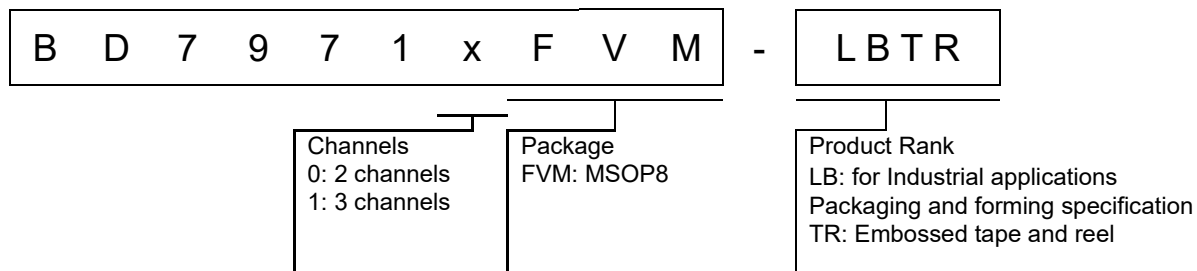

Figure 23. Example of Monolithic IC Structure

11. Ceramic Capacitor

When using a ceramic capacitor, determine a capacitance value considering the change of capacitance with temperature and the decrease in nominal capacitance due to DC bias and others.

Ordering Information



Marking Diagram

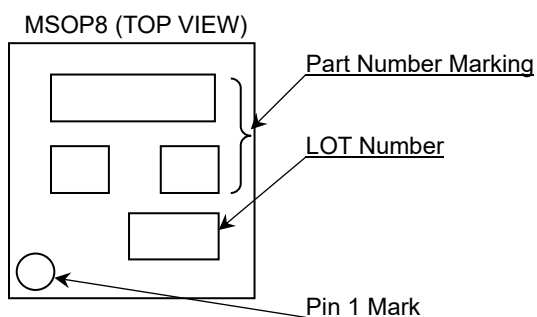

| Part Number Marking | Package | Orderable Part Number |
|---------------------|---------|-----------------------|
| 79710 | MSOP8 | BD79710FVM-LBTR |
| 79711 | | BD79711FVM-LBTR |

Physical Dimension and Packing Information

| | |
|--------------|-------|
| Package Name | MSOP8 |
|--------------|-------|

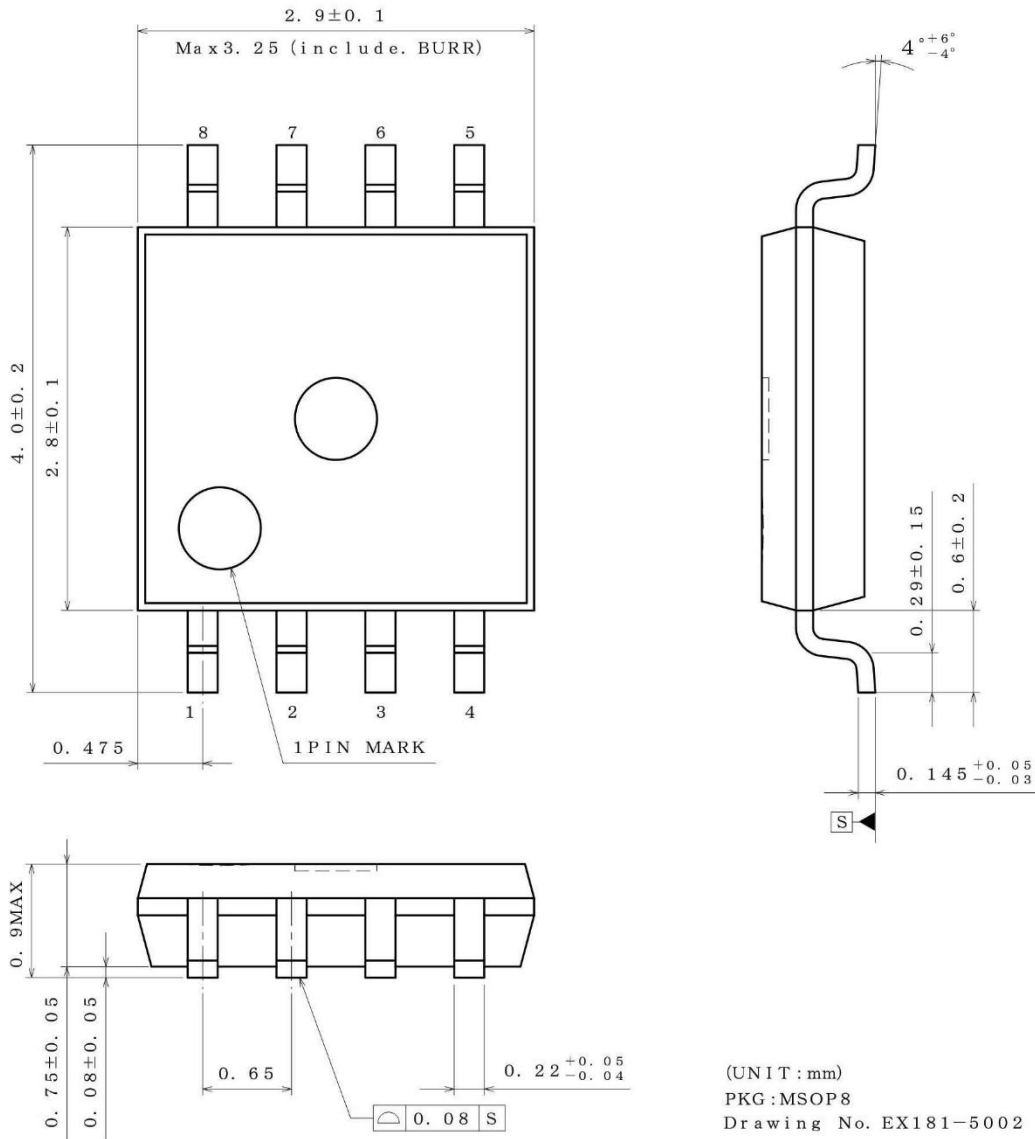

< Tape and Reel Information >

| | |
|-------------------|---|
| Tape | Embossed carrier tape |
| Quantity | 3000pcs |
| Direction of feed | TR (The direction is the 1pin of product is at the upper right when you hold) reel on the left hand and you pull out the tape on the right hand |

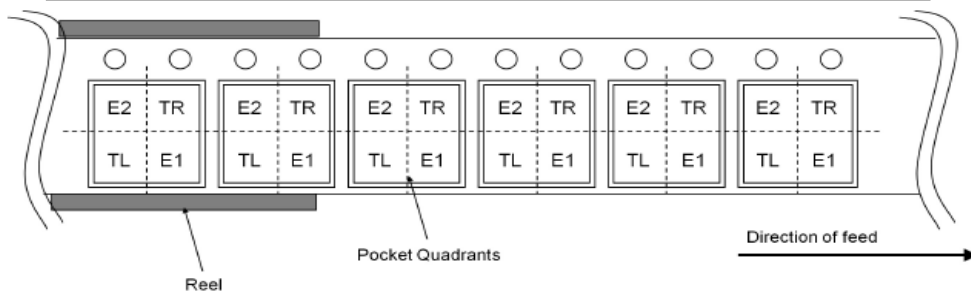

Revision History

| Date | Revision | Changes |
|-------------|----------|-------------|
| 20.Jan.2026 | 001 | New Release |

Notice

Precaution on using ROHM Products

1. If you intend to use our Products in devices requiring extremely high reliability (such as medical equipment ^(Note 1), aircraft/spacecraft, nuclear power controllers, etc.) and whose malfunction or failure may cause loss of human life, bodily injury or serious damage to property ("Specific Applications"), please consult with the ROHM sales representative in advance. Unless otherwise agreed in writing by ROHM in advance, ROHM shall not be in any way responsible or liable for any damages, expenses or losses incurred by you or third parties arising from the use of any ROHM's Products for Specific Applications.

(Note1) Medical Equipment Classification of the Specific Applications

| JAPAN | USA | EU | CHINA |
|-----------|-----------|------------|-----------|
| CLASS III | CLASS III | CLASS II b | CLASS III |
| CLASS IV | | CLASS III | |

2. ROHM designs and manufactures its Products subject to strict quality control system. However, semiconductor products can fail or malfunction at a certain rate. Please be sure to implement, at your own responsibilities, adequate safety measures including but not limited to fail-safe design against the physical injury, damage to any property, which a failure or malfunction of our Products may cause. The following are examples of safety measures:
 - [a] Installation of protection circuits or other protective devices to improve system safety
 - [b] Installation of redundant circuits to reduce the impact of single or multiple circuit failure
3. Our Products are not designed under any special or extraordinary environments or conditions, as exemplified below. Accordingly, ROHM shall not be in any way responsible or liable for any damages, expenses or losses arising from the use of any ROHM's Products under any special or extraordinary environments or conditions. If you intend to use our Products under any special or extraordinary environments or conditions (as exemplified below), your independent verification and confirmation of product performance, reliability, etc. prior to use, must be necessary:
 - [a] Use of our Products in any types of liquid, including water, oils, chemicals, and organic solvents
 - [b] Use of our Products outdoors or in places where the Products are exposed to direct sunlight or dust
 - [c] Use of our Products in places where the Products are exposed to sea wind or corrosive gases, including Cl₂, H₂S, NH₃, SO₂, and NO₂
 - [d] Use of our Products in places where the Products are exposed to static electricity or electromagnetic waves
 - [e] Use of our Products in proximity to heat-producing components, plastic cords, or other flammable items
 - [f] Sealing or coating our Products with resin or other coating materials
 - [g] Use of our Products without cleaning residue of flux (Exclude cases where no-clean type fluxes is used. However, recommend sufficiently about the residue.); or Washing our Products by using water or water-soluble cleaning agents for cleaning residue after soldering
 - [h] Use of the Products in places subject to dew condensation
4. The Products are not subject to radiation-proof design.
5. Please verify and confirm characteristics of the final or mounted products in using the Products.
6. In particular, if a transient load (a large amount of load applied in a short period of time, such as pulse, is applied, confirmation of performance characteristics after on-board mounting is strongly recommended. Avoid applying power exceeding normal rated power; exceeding the power rating under steady-state loading condition may negatively affect product performance and reliability.
7. De-rate Power Dissipation depending on ambient temperature. When used in sealed area, confirm that it is the use in the range that does not exceed the maximum junction temperature.
8. Confirm that operation temperature is within the specified range described in the product specification.
9. ROHM shall not be in any way responsible or liable for failure induced under deviant condition from what is defined in this document.

Precaution for Mounting / Circuit board design

1. When a highly active halogenous (chlorine, bromine, etc.) flux is used, the residue of flux may negatively affect product performance and reliability.
2. In principle, the reflow soldering method must be used on a surface-mount products, the flow soldering method must be used on a through hole mount products. If the flow soldering method is preferred on a surface-mount products, please consult with the ROHM representative in advance.

For details, please refer to ROHM Mounting specification

Precautions Regarding Application Examples and External Circuits

1. If change is made to the constant of an external circuit, please allow a sufficient margin considering variations of the characteristics of the Products and external components, including transient characteristics, as well as static characteristics.
2. You agree that application notes, reference designs, and associated data and information contained in this document are presented only as guidance for Products use. Therefore, in case you use such information, you are solely responsible for it and you must exercise your own independent verification and judgment in the use of such information contained in this document. ROHM shall not be in any way responsible or liable for any damages, expenses or losses incurred by you or third parties arising from the use of such information.

Precaution for Electrostatic

This Product is electrostatic sensitive product, which may be damaged due to electrostatic discharge. Please take proper caution in your manufacturing process and storage so that voltage exceeding the Products maximum rating will not be applied to Products. Please take special care under dry condition (e.g. Grounding of human body / equipment / solder iron, isolation from charged objects, setting of Ionizer, friction prevention and temperature / humidity control).

Precaution for Storage / Transportation

1. Product performance and soldered connections may deteriorate if the Products are stored in the places where:
 - [a] the Products are exposed to sea winds or corrosive gases, including Cl₂, H₂S, NH₃, SO₂, and NO₂
 - [b] the temperature or humidity exceeds those recommended by ROHM
 - [c] the Products are exposed to direct sunshine or condensation
 - [d] the Products are exposed to high Electrostatic
2. Even under ROHM recommended storage condition, solderability of products out of recommended storage time period may be degraded. It is strongly recommended to confirm solderability before using Products of which storage time is exceeding the recommended storage time period.
3. Store / transport cartons in the correct direction, which is indicated on a carton with a symbol. Otherwise bent leads may occur due to excessive stress applied when dropping of a carton.
4. Use Products within the specified time after opening a humidity barrier bag. Baking is required before using Products of which storage time is exceeding the recommended storage time period.

Precaution for Product Label

A two-dimensional barcode printed on ROHM Products label is for ROHM's internal use only.

Precaution for Disposition

When disposing Products please dispose them properly using an authorized industry waste company.

Precaution for Foreign Exchange and Foreign Trade act

Since concerned goods might be fallen under listed items of export control prescribed by Foreign exchange and Foreign trade act, please consult with ROHM in case of export.

Precaution Regarding Intellectual Property Rights

1. All information and data including but not limited to application example contained in this document is for reference only. ROHM does not warrant that foregoing information or data will not infringe any intellectual property rights or any other rights of any third party regarding such information or data.
2. ROHM shall not have any obligations where the claims, actions or demands arising from the combination of the Products with other articles such as components, circuits, systems or external equipment (including software).
3. No license, expressly or implied, is granted hereby under any intellectual property rights or other rights of ROHM or any third parties with respect to the Products or the information contained in this document. Provided, however, that ROHM will not assert its intellectual property rights or other rights against you or your customers to the extent necessary to manufacture or sell products containing the Products, subject to the terms and conditions herein.

Other Precaution

1. This document may not be reprinted or reproduced, in whole or in part, without prior written consent of ROHM.
2. The Products may not be disassembled, converted, modified, reproduced or otherwise changed without prior written consent of ROHM.
3. In no event shall you use in any way whatsoever the Products and the related technical information contained in the Products or this document for any military purposes, including but not limited to, the development of mass-destruction weapons.
4. The proper names of companies or products described in this document are trademarks or registered trademarks of ROHM, its affiliated companies or third parties.

General Precaution

1. Before you use our Products, you are requested to carefully read this document and fully understand its contents. ROHM shall not be in any way responsible or liable for failure, malfunction or accident arising from the use of any ROHM's Products against warning, caution or note contained in this document.
2. All information contained in this document is current as of the issuing date and subject to change without any prior notice. Before purchasing or using ROHM's Products, please confirm the latest information with a ROHM sales representative.
3. The information contained in this document is provided on an "as is" basis and ROHM does not warrant that all information contained in this document is accurate and/or error-free. ROHM shall not be in any way responsible or liable for any damages, expenses or losses incurred by you or third parties resulting from inaccuracy or errors of or concerning such information.