

For 3-phase DC Brushless Motor Level Shifter

BD67891MUV

General Description

BD67891MUV is a level-shifter that converts control logic signals from the ASIC to signals for direct driving of the external FET's gate as well as Hall and FG output signals from the motor side for input signals to the ASIC during 3-phase DC brushless motor driving.

Additional features include a current limit function that enables setting of the OFF time by external CR, a thermal shutdown circuit and under voltage lock out circuit for high reliability operation.

A power save function is also integrated that reduces circuit current during standby, contributing to greater overall energy savings.

Features

- Compatible with 2.5 V to 5.0 V ASICs
- Compatible with a Wide Range of Motor Power Supply Voltage (20 V to 40 V)
- Power Save Function (standby mode circuit current: $I_{MM} = 200 \mu A$ (Max))
- Current Limiter Function (OFF time set by external CR)
- Directly Driving External Pch/Nch FETs
- Built-in Logic Input Pull-down Resistor
- Thermal Shutdown Circuit (TSD)
- Under Voltage Lock Out Circuit (UVLO)
- Microminiature, Ultra-thin and High Heat-radiation (exposed metal type) Package

Applications

- Pre-drivers for 3-phase Motor
- Level Shifter

Package

VQFN032V5050

W (Typ) x D (Typ) x H (Max)

5.0 mm x 5.0 mm x 1.0 mm

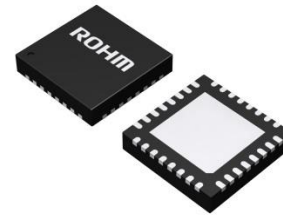

Pin Configuration

(TOP VIEW)

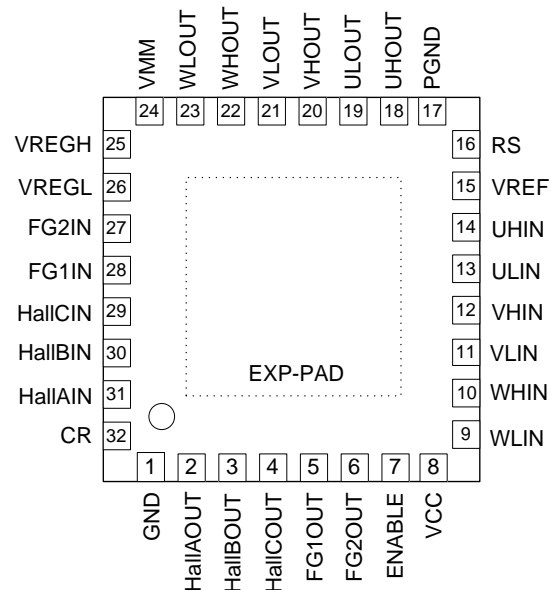

○Product structure : Silicon integrated circuit ○This product has no designed protection against radioactive rays

Pin Description

Pin No.	Pin name	Function	Pin No.	Pin name	Function
1	GND	Ground pin	17	PGND	Ground pin
2	HallAOUT	Hall signal output pin	18	UHOUT	External FET gate driving pin
3	HallBOUT	Hall signal output pin	19	ULOUT	External FET gate driving pin
4	HallCOUT	Hall signal output pin	20	VHOUT	External FET gate driving pin
5	FG1OUT	FG signal output pin	21	VLOUT	External FET gate driving pin
6	FG2OUT	FG signal output pin	22	WHOUT	External FET gate driving pin
7	ENABLE	Power save pin	23	WLOUT	External FET gate driving pin
8	VCC	Power supply pin	24	VMM	Power supply pin
9	WLIN	Logic input pin	25	VREGH	Reference voltage pin for external FET gate driving
10	WHIN	Logic input pin	26	VREGL	Reference voltage pin for external FET gate driving
11	VLIN	Logic input pin	27	FG2IN	FG signal input pin
12	VHIN	Logic input pin	28	FG1IN	FG signal input pin
13	ULIN	Logic input pin	29	HallCIN	Hall signal input pin
14	UHIN	Logic input pin	30	HallBIN	Hall signal input pin
15	VREF	Current limit value setting pin	31	HallAIN	Hall signal input pin
16	RS	Current limit comparator input pin	32	CR	Current limit off-time setting pin
-	EXP-PAD	The EXP-PAD is connected to GND.	-	-	-

Block Diagram and Applications Circuit Diagram

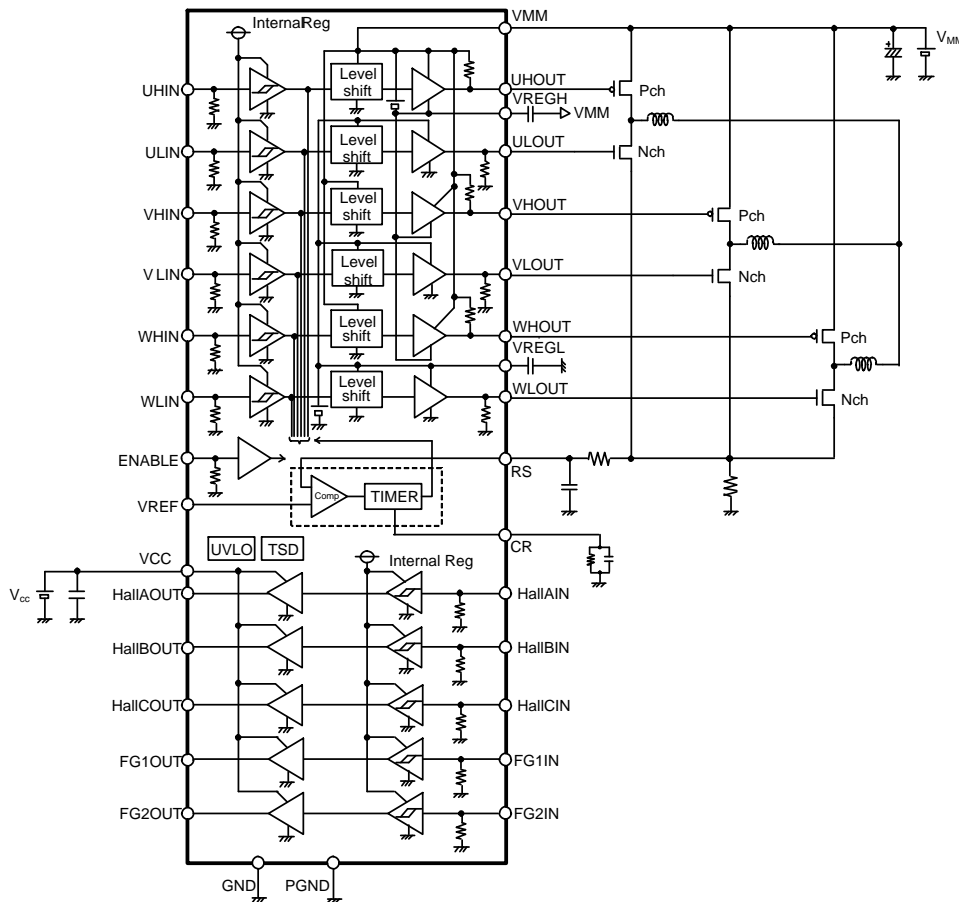

Absolute Maximum Ratings (Ta = 25 °C)

Parameter	Symbol	Limit	Unit
Supply Voltage	V _{MM}	45	V
Supply Voltage	V _{CC}	7	V
Control Input Voltage	V _{IN}	-0.2 to +7.0	V
Power Dissipation	P _d	880 ^(Note 1)	mW
Output Current	I _{OUT(DC)}	50 ^(Note 2)	mA
Storage Temperature Range	T _{stg}	-55 to +150	°C
Maximum Junction Temperature	T _{jmax}	150	°C

Caution 1: Operating the IC over the absolute maximum ratings may damage the IC. The damage can either be a short circuit between pins or an open circuit between pins and the internal circuitry. Therefore, it is important to consider circuit protection measures, such as adding a fuse, in case the IC is operated over the absolute maximum ratings.

Caution 2: Should by any chance the maximum junction temperature rating be exceeded the rise in temperature of the chip may result in deterioration of the properties of the chip. In case of exceeding this absolute maximum rating, design a PCB with power dissipation taken into consideration by increasing board size and copper area so as not to exceed the maximum junction temperature rating.

(Note 1) When mounted on a 74.2 mm × 74.2 mm × 1.6 mm glass epoxy board (Single-layer board with 20.2 mm² copper foil).

Derated at 7.04 mW/°C above Ta = 25 °C.

(Note 2) Do not exceed Pd and T_{jmax} = 150 °C.

Recommended Operating Conditions

Parameter	Symbol	Min	Typ	Max	Unit
Supply Voltage	V _{MM}	20	24	40	V
Supply Voltage	V _{CC}	2.3	3.3	5.5	V
Operating Temperature	T _{opr}	-25	+25	+85	°C

Electrical Characteristics (Unless otherwise specified $V_{MM} = 24\text{ V}$, $T_a = 25\text{ }^\circ\text{C}$, $V_{CC} = 3.3\text{ V}$)

Parameter	Symbol	Limit			Unit	Conditions
		Min	Typ	Max		
[Overall]						
Circuit Current 1	I_{MM1}	-	2.5	4.0	mA	ENABLE = L
Circuit Current 2	I_{MM2}	-	90	200	μA	ENABLE = H
Circuit Current 3	I_{CC}	-	65	200	μA	
[Driver Block]						
<Input> (UHIN, ULIN, VHIN, VLIN, WHIN, WLIN)						
High Level Input Current	I_{INH}	40	55	80	μA	$x_{HIN} = 5.5\text{ V}$, $x_{LIN} = 5.5\text{ V}$
High Level Input Voltage	V_{INH}	2.0	-	V_{CC}	V	
Low Level Input Voltage	V_{INL}	0	-	0.8	V	
<High Side FET Driver> (UHOUT, VHOUT, WHOUT, VREGH)						
VREGH Voltage	V_{REGH}	$V_{MM} - 8.95$	$V_{MM} - 8.15$	$V_{MM} - 7.35$	V	
High Level Output Voltage	$V_{OH\text{HOUT}}$	$V_{MM} - 0.50$	$V_{MM} - 0.25$	$V_{MM} - 0.10$	V	$I_o = -10\text{ mA}$
Low Level Output Voltage	$V_{OL\text{HOUT}}$	$V_{MM} - 8.75$	$V_{MM} - 7.80$	$V_{MM} - 6.75$	V	$I_o = 10\text{ mA}$
<Low Side FET Driver> (ULOUT, VLOUT, WLOUT, VREGL)						
VREGL Voltage	V_{REGL}	7.35	8.15	8.95	V	
High Level Output Voltage	$V_{OH\text{LOUT}}$	6.75	7.80	8.75	V	$I_o = -10\text{ mA}$
Low Level Output Voltage	$V_{OL\text{LOUT}}$	0.10	0.25	0.50	V	$I_o = 10\text{ mA}$
[Current Limit Block]						
RS Input Current	I_{RS}	-2.0	-0.1	-	μA	$RS = 0\text{ V}$, $V_{REF} = 1.0\text{ V}$
VREF Input Current	I_{VREF}	-2.0	-0.1	-	μA	$RS = 1.0\text{ V}$, $V_{REF} = 0\text{ V}$
VREF Input Voltage	V_{REF}	0	-	1.0	V	
Comparator Input Offset Voltage	V_{OFS}	-8	-	8	mV	$T_a = -25\text{ }^\circ\text{C}$ to $+85\text{ }^\circ\text{C}$
[Hall/FG Signal Block] (HallAIN, HallBIN, HallCIN, FG1IN, FG2IN, HallAOUT, HallBOUT, HallCOUT, FG1OUT, FG2OUT)						
High Level Input Current	I_{INH}	40	55	80	μA	$HallxIN = 5.5\text{ V}$, $FGxIN = 5.5\text{ V}$
High Level Input Voltage	V_{INH}	2.0	-	5.5	V	
Low Level Input Voltage	V_{INL}	0	-	0.8	V	
High Level Output Voltage	V_{OH}	$V_{CC} - 0.08$	$V_{CC} - 0.04$	-	V	$I_o = -1\text{ mA}$
Low Level Output Voltage	V_{OL}	-	0.04	0.08	V	$I_o = 1\text{ mA}$
[ENABLE Signal Block]						
High Level Input Current	I_{ENH}	70	100	140	μA	ENABLE = 5.5 V
High Level Input Voltage	V_{ENH}	2.0	-	V_{CC}	V	
Low Level Input Voltage	V_{ENL}	0	-	0.8	V	

Function Explanation

1 **ENABLE Pin**

This pin is used to saving power. Supplying H voltage to the ENABLE pin initiates power save mode and reduces the circuit current I_{MM} to 200 μ A or less. In power save mode, all pre-driver outputs are OFF. But the external FET does not turn on because a pull-down or pull-up resistor is integrated. Be careful because there is a delay of 40 μ s (Max) before it is returned from standby state to normal state and the pre-driver output becomes ACTIVE.

ENABLE	State
L	ACTIVE
H	STAND-BY

2 **UHIN, ULIN, VHIN, VLIN, WHIN, WLIN Pin**

These pins control the logic of the pre-driver output.

ENABLE	xHIN	xLIN	xHOUT	xLOUT
L	L	L	V_{MM}	0 V
L	L	H	V_{MM}	8.15 V (Typ)
L	H	L	$V_{MM} - 8.15$ V (Typ)	0 V
L	H	H	V_{MM}	0 V
H	Don't care	Don't care	V_{MM} (OPEN)	0 V (OPEN)

A pull-down resistor of 100 k Ω is integrated, along with a hysteresis function (200 mV (Typ)). In order to prevent malfunction and/or damage due to simultaneous ON, all external FETs are turned OFF when (xHIN, xLIN) is (H, H). Dead time that occurs during simultaneous ON while the motor is in operation can be controlled by ASIC signals.

3 **VREGH Pin**

This internally generated reference voltage is used for driving external high side Pch FET gate. The VREGH pin should be decoupled with a 0.1 μ F to 0.22 μ F capacitor to V_{MM} .

4 **VREGL Pin**

This internally generated reference voltage is used for driving external low side Nch FET gate. The VREGL pin should be decoupled with a 0.1 μ F to 0.22 μ F capacitor to GND.

5 **UHOUT, VHOUT, WHOUT Pin**

These pins drive the gate of the external high side Pch FET. A pull-up resistor of 200 k Ω is integrated between the output pin and V_{MM} .

6 **ULOUT, VLOUT, WLOUT Pin**

These pins drive the gate of the external low side Nch FET. A pull-down resistor of 200 k Ω is integrated between the output pin and GND.

7 **HallAIN, HallBIN, HallCIN, FG1IN, FG2IN Pin**

These pins are used for inputting the Hall and FG signals. A pull-down resistor of 100 k Ω is integrated, along with hysteresis (200 mV (Typ)).

8 **HallAOUT, HallBOUT, HallCOUT, FG1OUT, FG2OUT Pin**

The signals inputted to the HallAIN, HallBIN, HallCIN, FG1IN, and FG2IN pins are output from these pins through the level shifter circuit. The output H voltage is approx the V_{cc} . Therefore, connecting the VCC pin to the ASIC power supply will cause the voltages to be equal and ensure that the signals output from the IC is matched to the ASIC.

Function Explanation – continued

9 VREF Pin

This pin is used to set the value of the current limit.

The current limit value (I_{LIMIT}) can be set by the VREF pin voltage and current-detecting resistor(RNF), be expressed the following equation:

$$I_{LIMIT} = \{(V_{REF} + V_{OFS})\} \times \frac{1}{RNF} \quad [A]$$

I_{LIMIT} : is the output current.
 V_{REF} : is the voltage of output current value-setting pin.
 V_{OFS} : is comparator input offset voltage.
 RNF : is the current-detecting resistor.

Set the VREF pin voltage to within the VREF input voltage range (0 V to 1 V).

Avoid leaving the VREF pin open, since doing so may cause the input to become unstable and VREF pin voltage to increase, which may lead to over-current and, ultimately, malfunction and/or damage. In addition, take into consideration the outflow current (2 μ A (Max)) when selecting the resistor value for the resistor divider.

10 RS Pin

This pin is used to input the voltage transformed by the current-detecting resistor from the current flowing through the motor. The current-detecting resistor should be connected between the RS pin and GND.

In addition, select a resistor value for the current-detecting resistor so that the power consumption $W = I_{OUT}^2 \cdot R$ [W] does not exceed the rated power dissipation of the resistor. Current limiting operation is performed by comparing the VREF pin voltage with the RS pin voltage. Note that signals input to the RS pin may include PWM switching noise contained in the RS pin voltage. Therefore, it is recommended that the voltage input to the RS pin be processed by a low pass filter. Consideration must also be given to the wiring pattern in order to minimize impedance and prevent common impedance from occurring with other Ground patterns. Because the motor drive current flows from the Source pin of the external Nch FET through the current detection resistor to GND.

11 CR Pin

This pin is used to set the OFF time during current limiting operation.

Connect the external C (330 pF to 1500 pF) and R (15 k Ω to 200 k Ω) between the CR pin and GND.

The following formula is used to determine the OFF time:

$$t_{OFF} [s] = C \cdot R \cdot 0.916$$

Configure the circuit so that other Ground patterns do not share common impedance with the pattern between the external CR circuit and Ground. And implement designs in such a way that steep pulses (i.e. square waves) are not generated or noise introduced.

12 IC Back metal

The VQFN032V5050 package has a metal for heat dissipation on the back of the IC. Since it is assumed to be used by applying heat dissipation treatment to this metal, always GND on the substrate connect with the plane and solder, and use the GND pattern widely to ensure sufficient heat dissipation area. In addition, the backside metal is short with the back of the IC chip, so it has become a GND potential. Because there is a possibility of malfunction and destruction when it is short and the potential other than GND, never pass the wiring pattern other than GND on the back of the IC.

Current Limiting Function

1 Current Limit Operation

The motor rotates by switching ON and OFF the external FET, which causes current to flow through the motor. This current is transformed by voltage by the current detecting resistor, then passed through a CR filter before being input to the RS pin (since it most likely contains PWM switching noise). If the motor current increases and the RS pin voltage reaches the VREF pin voltage, the current limit comparator will activate and turn OFF the external FET. The output will be turned ON once the OFF time (t_{OFF}) is reached (determined by the CR timer).

2 Minimum ON time

During this time current limit operation is in effect and the output stage will turn ON after the OFF time has elapsed. The minimum ON time is determined by the external CR timer.

3 Current Limit Value Setting Example

First let us suppose that the current detecting resistor (RNF) is 0.05Ω with an output current of 5 A: If the Comparator Input Offset Voltage is 0 mV, the formula becomes:

$$5 [A] = V_{REF} / 0.05 [\Omega] \rightarrow V_{REF} = 0.25 [V]$$

The VREF pin voltage should be set 0.25 V by resistors.

The outflow current at the VREF pin is $2 \mu A$ (Max). It is important to set a bias current that will not cause fluctuation of the reference potential of the resistor division due to this outflow current.

For example, we will consider the effects of supplying a current 100 times larger than $2 \mu A$ ($200 \mu A$).

If the voltage applied to the resistor division is 5 V:

$$5 [V] / 200 [\mu A] = 25 [k\Omega]$$

This resistor value is then broken up among two resistors,

$$(R_1 + R_2 = 25 [k\Omega])$$

Therefore, to ensure a VREF pin voltage of 0.25 V,

$$5 [V] \times \frac{R_2}{R_1 + R_2} = 0.25 [V]$$

$$\therefore R_2 = 1.25 [k\Omega]$$

From the total resistor requirement above, we arrive at the appropriate resistor values:

$$R_1 = 23.75 k\Omega \text{ and } R_2 = 1.25 k\Omega$$

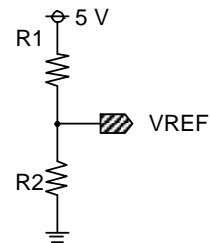

4 CR Timer

The CR filter connected to the CR pin is repeatedly charged and discharged between the VCRH and VCRL levels. The output of the internal comparator is masked while charging from VCRL to VCRH in order to cancel noise. This period defines the minimum ON-time of the motor output transistor. The CR pin begins discharging once the voltage reaches VCRH. When the output current reaches the current limit during this period (i.e. RS voltage reaches the VREF pin voltage), then the output is switched turn off. The CR continues to discharge during this period until it reaches VCRL, at which point the IC output is switched back ON. The current output and CR pin begin charging simultaneously. The CR charge time (t_{ONMIN}) and discharge time ($t_{DISCHARGE}$) are set by external components, according to the following formulas (Typ).

$$t_{ONMIN} \cong C \times \frac{R' \times R}{R' + R} \times \ln \left(\frac{V_{CR} - 1.0}{V_{CR} - 2.5} \right) [s]$$

- t_{ONMIN} : is the minimum ON-time.
- C : is the capacitance of the CR Pin.
- R : is the resistance of the CR Pin.
- R' : is the CR Pin internal impedance $5 k\Omega$ (Typ)
- V_{CR} : is the CR Pin voltage.

$$V_{CR} = V \times \frac{R}{R' + R} [V]$$

- V : is the internal regulator voltage 5 V (Typ)

$$t_{DISCHARGE} \cong C \times R \times 0.916 [s]$$

- $t_{DISCHARGE}$: is the CR discharge time.

4 CR Timer – continued

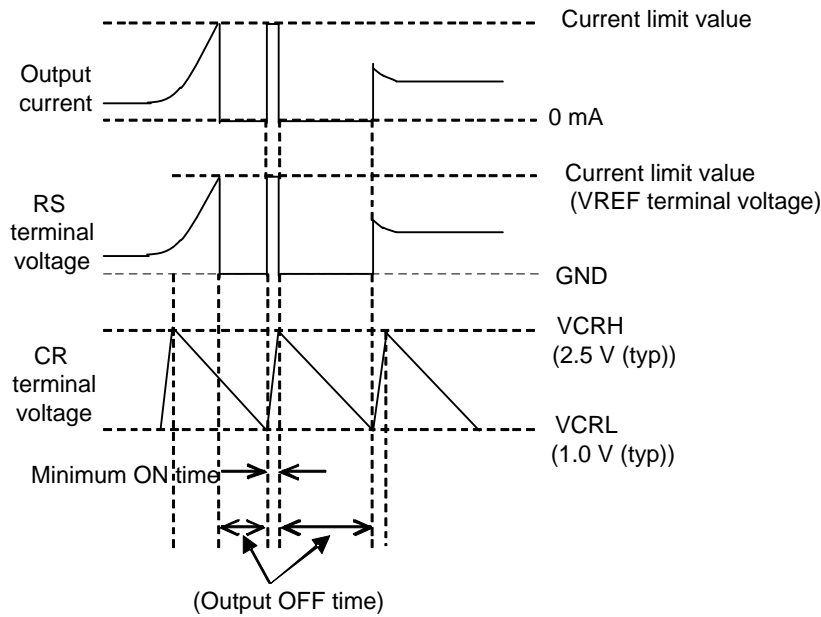

Input/Output Delay Times

Parameter	Symbol	Limit			Unit	Condition
		Min	Typ	Max		
Driver block						
<High side FET driver> (UHOUT, VHOUT, WHOUT)						
Propagation delay time 1	t_{1H}	-	50	100	ns	
Propagation delay time 2	t_{2H}	-	60	100	ns	
<Low side FET driver> (ULOUT, VLOUT, WLOUT)						
Propagation delay time 1	t_{1L}	-	40	100	ns	
Propagation delay time 2	t_{2L}	-	50	100	ns	
Hall/FG signal block (HallAIN, HallBIN, HallCIN, FG1IN, FG2IN, HallAOUT, HallBOUT, HallCOUT, FG1OUT, FG2OUT)						
Propagation delay time 1	t_1	-	20	100	ns	
Propagation delay time 2	t_2	-	50	100	ns	

Input control signals after taking into consideration the delay time of the driver block in order to prevent turning on the external FETs simultaneously, which may result in malfunction and/or damage.

Rise/Fall times

Parameter	Symbol	Limit			Unit	Condition
		Min	Typ	Max		
Driver block						
<High side FET driver> (UHOUT, VHOUT, WHOUT)						
Output transition time 1	t_{rH}	-	60	200	ns	<p>load = 1000 pF//3.8 MΩ</p>
Output transition time 2	t_{fH}	-	80	200	ns	
<Low side FET driver> (ULOUT, VLOUT, WLOUT)						
Output transition time 1	t_{rL}	-	70	200	ns	<p>load = 1000 pF//3.8 MΩ</p>
Output transition time 2	t_{fL}	-	70	200	ns	

Lengthen the times by connecting external CR circuits as shown below.

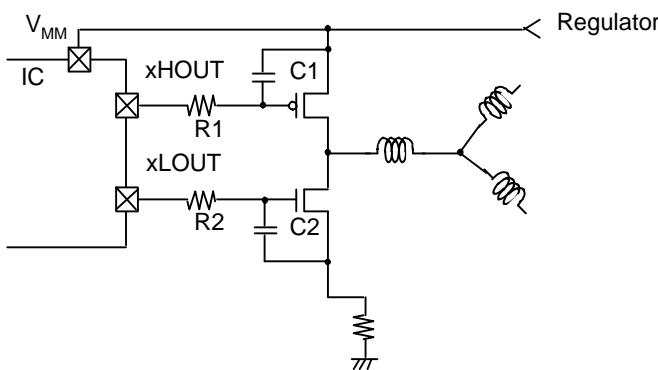

Protection Circuits

1 Thermal Shutdown (TSD)

A thermal shutdown circuit is built in for protection against overheating. When the chip temperature rises 175 °C (Typ) or more, the output of pre-driver is controlled as the external FETs turns OFF. Normal operation automatically resumes once the temperature decreases to 150 °C (Typ) or less. Note that if heat is externally added damage may occur, even if TSD is in operation.

2 Under Voltage Lock Out (UVLO)

This IC has a built-in under voltage lock out function to prevent false operation such as IC output during power supply under voltage. When the applied voltage to the VMM pin goes to 15 V (Typ) or less, the output of pre-driver is controlled as the external FETs turn OFF. This switching voltage has 1 V (Typ) hysteresis to prevent false operation by noise etc. Be aware that this circuit does not operate during power save mode.

I/O Equivalence Circuit

No.	Pin Name	Equivalence Circuit	No.	Pin Name	Equivalence Circuit
31	HallAIN		2	HallAOUT	
30	HallBIN				
29	HallCIN				
28	FG1IN				
27	FG2IN				
18	UHOUT			15	
20	VHOUT				
22	WHOUT				
25	VREGH				
19	ULOUT		7	ENABLE	
21	VLOUT				
23	WLOUT				
26	VREGL				
14	UHIN		32	CR	
13	ULIN				
12	VHIN				
11	VLIN				
10	WHIN				
9	WLIN				

Operational Notes

1 Reverse Connection of Power Supply

Connecting the power supply in reverse polarity can damage the IC. Take precautions against reverse polarity when connecting the power supply, such as mounting an external diode between the power supply and the IC's power supply pins.

2 Power Supply Lines

Design the PCB layout pattern to provide low impedance supply lines. Furthermore, connect a capacitor to ground at all power supply pins. Consider the effect of temperature and aging on the capacitance value when using electrolytic capacitors.

3 Ground Voltage

Ensure that no pins are at a voltage below that of the ground pin at any time, even during transient condition.

4 Ground Wiring Pattern

When using both small-signal and large-current ground traces, the two ground traces should be routed separately but connected to a single ground at the reference point of the application board to avoid fluctuations in the small-signal ground caused by large currents. Also ensure that the ground traces of external components do not cause variations on the ground voltage. The ground lines must be as short and thick as possible to reduce line impedance.

5 Recommended Operating Conditions

The function and operation of the IC are guaranteed within the range specified by the recommended operating conditions. The characteristic values are guaranteed only under the conditions of each item specified by the electrical characteristics.

6 Inrush Current

When power is first supplied to the IC, it is possible that the internal logic may be unstable and inrush current may flow instantaneously due to the internal powering sequence and delays, especially if the IC has more than one power supply. Therefore, give special consideration to power coupling capacitance, power wiring, width of ground wiring, and routing of connections.

7 Testing on Application Boards

When testing the IC on an application board, connecting a capacitor directly to a low-impedance output pin may subject the IC to stress. Always discharge capacitors completely after each process or step. The IC's power supply should always be turned off completely before connecting or removing it from the test setup during the inspection process. To prevent damage from static discharge, ground the IC during assembly and use similar precautions during transport and storage.

8 Inter-pin Short and Mounting Errors

Ensure that the direction and position are correct when mounting the IC on the PCB. Incorrect mounting may result in damaging the IC. Avoid nearby pins being shorted to each other especially to ground, power supply and output pin. Inter-pin shorts could be due to many reasons such as metal particles, water droplets (in very humid environment) and unintentional solder bridge deposited in between pins during assembly to name a few.

9 Unused Input Pins

Input pins of an IC are often connected to the gate of a MOS transistor. The gate has extremely high impedance and extremely low capacitance. If left unconnected, the electric field from the outside can easily charge it. The small charge acquired in this way is enough to produce a significant effect on the conduction through the transistor and cause unexpected operation of the IC. So unless otherwise specified, unused input pins should be connected to the power supply or ground line.

Operational Notes – continued

10 Regarding the Input Pin of the IC

This monolithic IC contains P+ isolation and P substrate layers between adjacent elements in order to keep them isolated. P-N junctions are formed at the intersection of the P layers with the N layers of other elements, creating a parasitic diode or transistor. For example (refer to figure below):

- When $GND > Pin\ A$ and $GND > Pin\ B$, the P-N junction operates as a parasitic diode.
- When $GND > Pin\ B$, the P-N junction operates as a parasitic transistor.

Parasitic diodes inevitably occur in the structure of the IC. The operation of parasitic diodes can result in mutual interference among circuits, operational faults, or physical damage. Therefore, conditions that cause these diodes to operate, such as applying a voltage lower than the GND voltage to an input pin (and thus to the P substrate) should be avoided.

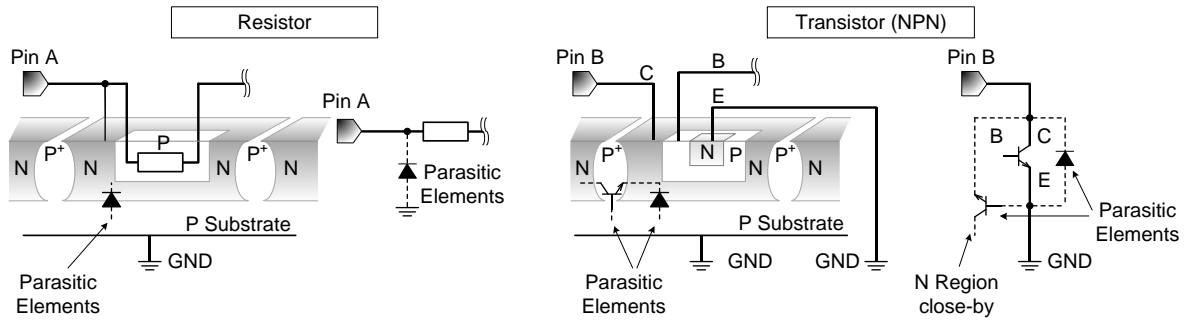

Example of Monolithic IC Structure

11 Ceramic Capacitor

When using a ceramic capacitor, determine a capacitance value considering the change of capacitance with temperature and the decrease in nominal capacitance due to DC bias and others.

12 Thermal Shutdown Circuit (TSD)

This IC has a built-in thermal shutdown circuit that prevents heat damage to the IC. Normal operation should always be within the IC's maximum junction temperature rating. If however the rating is exceeded for a continued period, the junction temperature (T_j) will rise which will activate the TSD circuit that will turn OFF power output pins. When the T_j falls below the TSD threshold, the circuits are automatically restored to normal operation.

Note that the TSD circuit operates in a situation that exceeds the absolute maximum ratings and therefore, under no circumstances, should the TSD circuit be used in a set design or for any purpose other than protecting the IC from heat damage.

13 Over Current Protection Circuit (OCP)

This IC incorporates an integrated overcurrent protection circuit that is activated when the load is shorted. This protection circuit is effective in preventing damage due to sudden and unexpected incidents. However, the IC should not be used in applications characterized by continuous operation or transitioning of the protection circuit.

Ordering Information

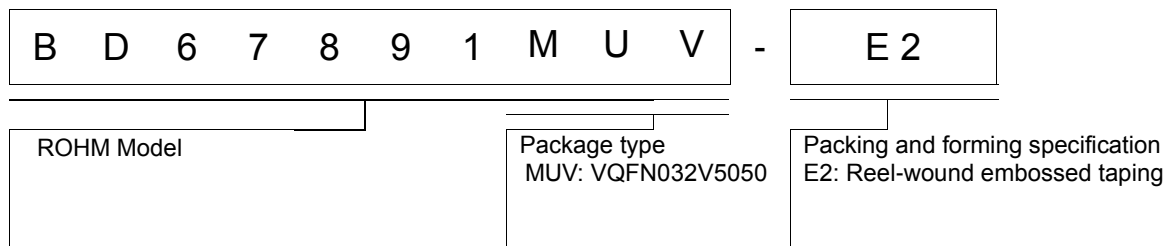

Marking Diagram

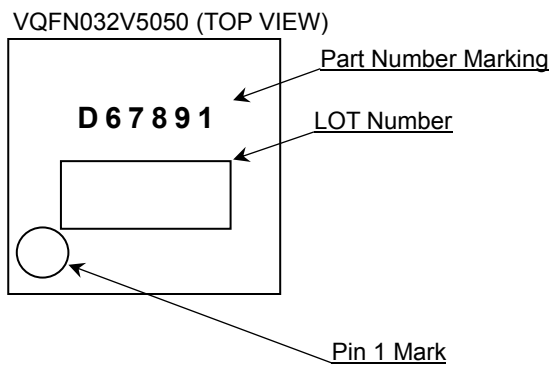

Physical Dimension and Packing Information

Package Name	VQFN032V5050
--------------	--------------

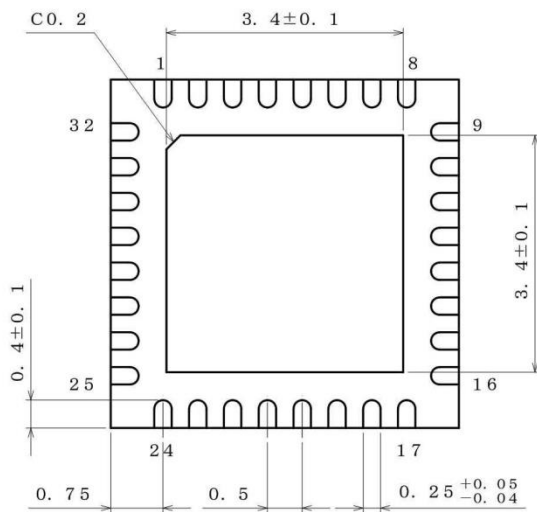
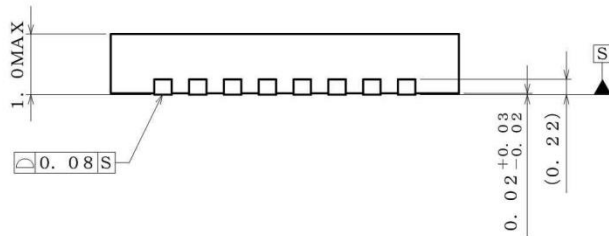
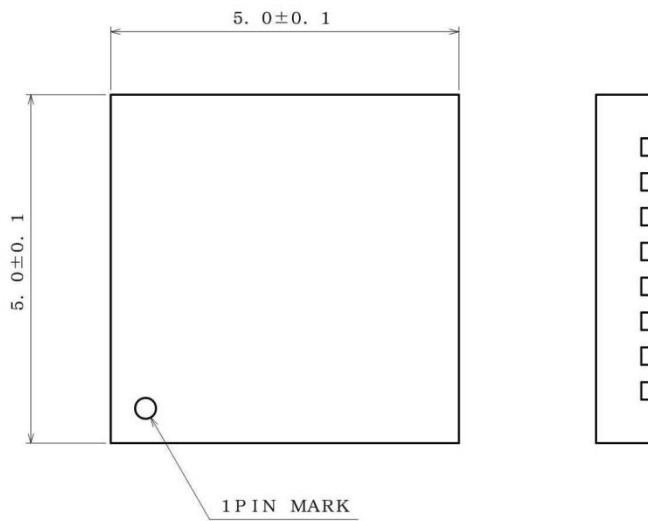

(UNIT : mm)
 PKG : VQFN032V5050
 Drawing No. EX461-5001-2

< Tape and Reel Information >

Tape	Embossed carrier tape
Quantity	2500pcs
Direction of feed	E2 The direction is the pin 1 of product is at the upper left when you hold reel on the left hand and you pull out the tape on the right hand

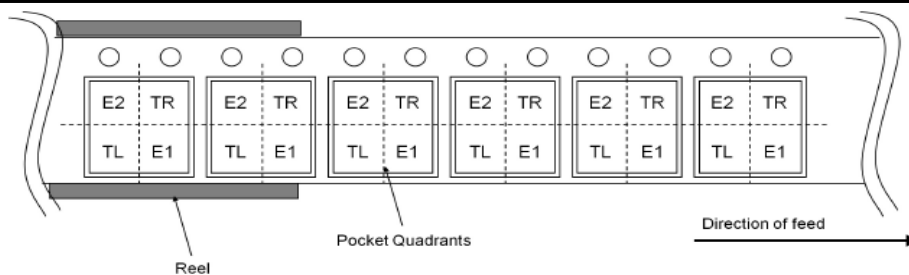

Revision History

Date	Revision	Changes
21.Dec.2020	001	New Release

Ordering Information

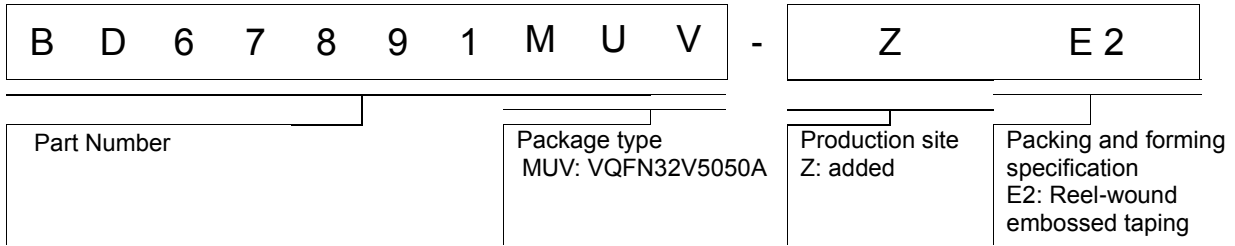

Marking Diagram

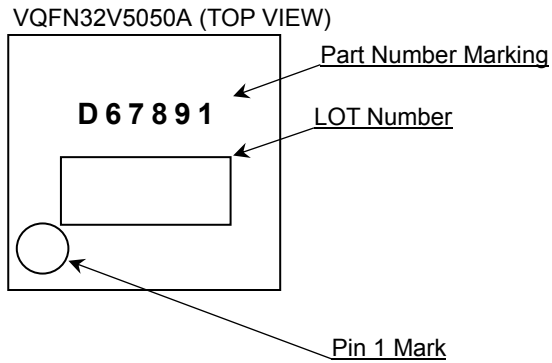

Physical Dimension and Packing Information

Package Name	VQFN32V5050A
--------------	--------------

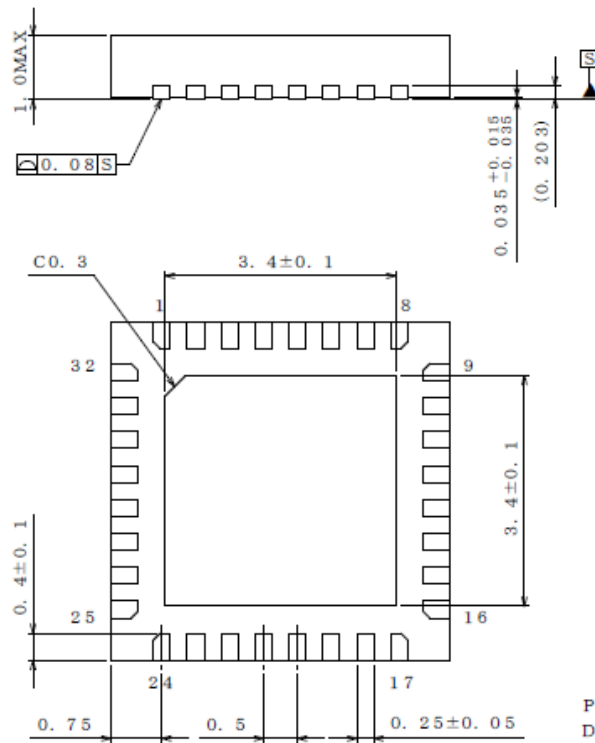
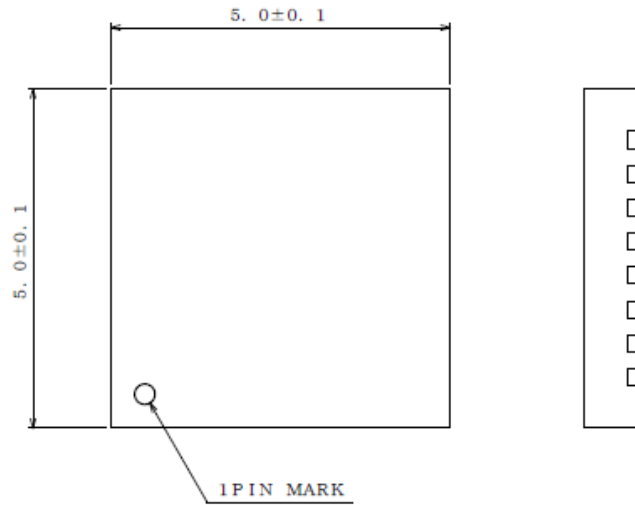

(UNIT : mm)

PKG : VQFN32V5050A
Drawing No. EX001-0030

< Tape and Reel Information >

Tape	Embossed carrier tape
Quantity	2500pcs
Direction of feed	E2 The direction is the pin 1 of product is at the upper left when you hold reel on the left hand and you pull out the tape on the right hand

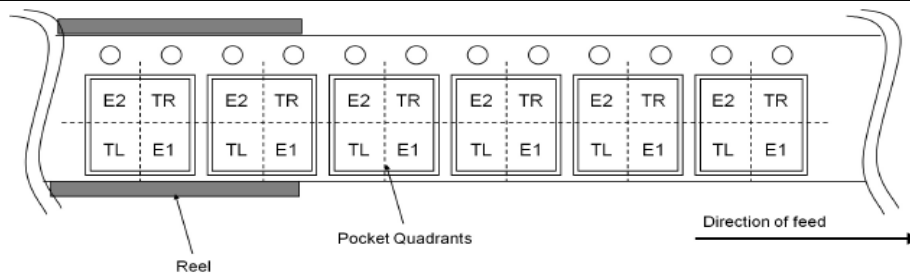

Notice

Precaution on using ROHM Products

- Our Products are designed and manufactured for application in ordinary electronic equipment (such as AV equipment, OA equipment, telecommunication equipment, home electronic appliances, amusement equipment, etc.). If you intend to use our Products in devices requiring extremely high reliability (such as medical equipment ^(Note 1), transport equipment, traffic equipment, aircraft/spacecraft, nuclear power controllers, fuel controllers, car equipment including car accessories, safety devices, etc.) and whose malfunction or failure may cause loss of human life, bodily injury or serious damage to property ("Specific Applications"), please consult with the ROHM sales representative in advance. Unless otherwise agreed in writing by ROHM in advance, ROHM shall not be in any way responsible or liable for any damages, expenses or losses incurred by you or third parties arising from the use of any ROHM's Products for Specific Applications.

(Note1) Medical Equipment Classification of the Specific Applications

JAPAN	USA	EU	CHINA
CLASS III	CLASS III	CLASS II b	CLASS III
CLASS IV		CLASS III	

- ROHM designs and manufactures its Products subject to strict quality control system. However, semiconductor products can fail or malfunction at a certain rate. Please be sure to implement, at your own responsibilities, adequate safety measures including but not limited to fail-safe design against the physical injury, damage to any property, which a failure or malfunction of our Products may cause. The following are examples of safety measures:
 - Installation of protection circuits or other protective devices to improve system safety
 - Installation of redundant circuits to reduce the impact of single or multiple circuit failure
- Our Products are designed and manufactured for use under standard conditions and not under any special or extraordinary environments or conditions, as exemplified below. Accordingly, ROHM shall not be in any way responsible or liable for any damages, expenses or losses arising from the use of any ROHM's Products under any special or extraordinary environments or conditions. If you intend to use our Products under any special or extraordinary environments or conditions (as exemplified below), your independent verification and confirmation of product performance, reliability, etc. prior to use, must be necessary:
 - Use of our Products in any types of liquid, including water, oils, chemicals, and organic solvents
 - Use of our Products outdoors or in places where the Products are exposed to direct sunlight or dust
 - Use of our Products in places where the Products are exposed to sea wind or corrosive gases, including Cl₂, H₂S, NH₃, SO₂, and NO₂
 - Use of our Products in places where the Products are exposed to static electricity or electromagnetic waves
 - Use of our Products in proximity to heat-producing components, plastic cords, or other flammable items
 - Sealing or coating our Products with resin or other coating materials
 - Use of our Products without cleaning residue of flux (Exclude cases where no-clean type fluxes is used. However, recommend sufficiently about the residue.) ; or Washing our Products by using water or water-soluble cleaning agents for cleaning residue after soldering
 - Use of the Products in places subject to dew condensation
- The Products are not subject to radiation-proof design.
- Please verify and confirm characteristics of the final or mounted products in using the Products.
- In particular, if a transient load (a large amount of load applied in a short period of time, such as pulse, is applied, confirmation of performance characteristics after on-board mounting is strongly recommended. Avoid applying power exceeding normal rated power; exceeding the power rating under steady-state loading condition may negatively affect product performance and reliability.
- De-rate Power Dissipation depending on ambient temperature. When used in sealed area, confirm that it is the use in the range that does not exceed the maximum junction temperature.
- Confirm that operation temperature is within the specified range described in the product specification.
- ROHM shall not be in any way responsible or liable for failure induced under deviant condition from what is defined in this document.

Precaution for Mounting / Circuit board design

- When a highly active halogenous (chlorine, bromine, etc.) flux is used, the residue of flux may negatively affect product performance and reliability.
- In principle, the reflow soldering method must be used on a surface-mount products, the flow soldering method must be used on a through hole mount products. If the flow soldering method is preferred on a surface-mount products, please consult with the ROHM representative in advance.

For details, please refer to ROHM Mounting specification

Precautions Regarding Application Examples and External Circuits

1. If change is made to the constant of an external circuit, please allow a sufficient margin considering variations of the characteristics of the Products and external components, including transient characteristics, as well as static characteristics.
2. You agree that application notes, reference designs, and associated data and information contained in this document are presented only as guidance for Products use. Therefore, in case you use such information, you are solely responsible for it and you must exercise your own independent verification and judgment in the use of such information contained in this document. ROHM shall not be in any way responsible or liable for any damages, expenses or losses incurred by you or third parties arising from the use of such information.

Precaution for Electrostatic

This Product is electrostatic sensitive product, which may be damaged due to electrostatic discharge. Please take proper caution in your manufacturing process and storage so that voltage exceeding the Products maximum rating will not be applied to Products. Please take special care under dry condition (e.g. Grounding of human body / equipment / solder iron, isolation from charged objects, setting of Ionizer, friction prevention and temperature / humidity control).

Precaution for Storage / Transportation

1. Product performance and soldered connections may deteriorate if the Products are stored in the places where:
 - [a] the Products are exposed to sea winds or corrosive gases, including Cl₂, H₂S, NH₃, SO₂, and NO₂
 - [b] the temperature or humidity exceeds those recommended by ROHM
 - [c] the Products are exposed to direct sunshine or condensation
 - [d] the Products are exposed to high Electrostatic
2. Even under ROHM recommended storage condition, solderability of products out of recommended storage time period may be degraded. It is strongly recommended to confirm solderability before using Products of which storage time is exceeding the recommended storage time period.
3. Store / transport cartons in the correct direction, which is indicated on a carton with a symbol. Otherwise bent leads may occur due to excessive stress applied when dropping of a carton.
4. Use Products within the specified time after opening a humidity barrier bag. Baking is required before using Products of which storage time is exceeding the recommended storage time period.

Precaution for Product Label

A two-dimensional barcode printed on ROHM Products label is for ROHM's internal use only.

Precaution for Disposition

When disposing Products please dispose them properly using an authorized industry waste company.

Precaution for Foreign Exchange and Foreign Trade act

Since concerned goods might be fallen under listed items of export control prescribed by Foreign exchange and Foreign trade act, please consult with ROHM in case of export.

Precaution Regarding Intellectual Property Rights

1. All information and data including but not limited to application example contained in this document is for reference only. ROHM does not warrant that foregoing information or data will not infringe any intellectual property rights or any other rights of any third party regarding such information or data.
2. ROHM shall not have any obligations where the claims, actions or demands arising from the combination of the Products with other articles such as components, circuits, systems or external equipment (including software).
3. No license, expressly or implied, is granted hereby under any intellectual property rights or other rights of ROHM or any third parties with respect to the Products or the information contained in this document. Provided, however, that ROHM will not assert its intellectual property rights or other rights against you or your customers to the extent necessary to manufacture or sell products containing the Products, subject to the terms and conditions herein.

Other Precaution

1. This document may not be reprinted or reproduced, in whole or in part, without prior written consent of ROHM.
2. The Products may not be disassembled, converted, modified, reproduced or otherwise changed without prior written consent of ROHM.
3. In no event shall you use in any way whatsoever the Products and the related technical information contained in the Products or this document for any military purposes, including but not limited to, the development of mass-destruction weapons.
4. The proper names of companies or products described in this document are trademarks or registered trademarks of ROHM, its affiliated companies or third parties.