

# 36 V High-performance, High-Reliability Unipolar Stepping Motor Driver

## BM6343AFS-Z

### General Description

BM6343AFS-Z is a unipolar stepping motor driver. Rated power supply voltage of the device is 36 V, rated output voltage is 100 V, and rated output current is 3.0 A. CLK-IN Driving Mode and 3-wire Serial Communication Mode is adopted for input interface, and excitation mode is corresponding to FULL STEP mode, HALF STEP mode and QUARTER STEP mode via a built-in DAC. In addition, the power supply may be driven by one single system, which simplifies the design.

### Key Specifications

- Rated Input Voltage: 36 V
- Rated Output Voltage: 100 V
- Rated Output Current (Continuous): 3.0 A/ phase
- Rated Output Current (Peak Value): 3.5 A/ phase
- Operating Temperature Range: -25 °C to +85 °C
- Output ON Resistance: 0.1 Ω (Typ)

### Package

SSOP-A54\_36A

### W (Typ) x D (Typ) x H (Max)

22.0 mm x 14.1 mm x 2.4 mm

### Features

- Single Power Supply Input (Rated Voltage of 36 V)
- Rated Output Current: 3.0 A
- Rated Output Current (Peak): 3.5 A
- Low ON Resistance DMOS Output
- Power Save Function
- Power-on Reset Function
- CLK-IN Drive Mode
- 3-wire Serial Communication Mode
- PWM Constant Current Control (Current Limit Function)
- Built-in Spike Noise Cancel Function (External Noise Filter is Unnecessary)
- FULL STEP, HALF STEP and QUARTER STEP Functionality
- Freely Timing Excitation Mode Switch
- Normal Rotation & Reverse Rotation Switching Function
- Built-in Logic Input Pull-Down Resistor
- Thermal Shutdown Circuit (TSD)
- Under Voltage Lock Out Circuit (UVLO)
- Over Voltage Lock Out Circuit (OVLO)
- Protects Against Malfunction when Power Supply is Disconnected (Ghost Supply Prevention Function)

### Application

- Carry Paper Currency, Ticket Machine, Amuse, PPC, Multi-Function Printer, Laser Beam Printer



### Typical Application Circuit

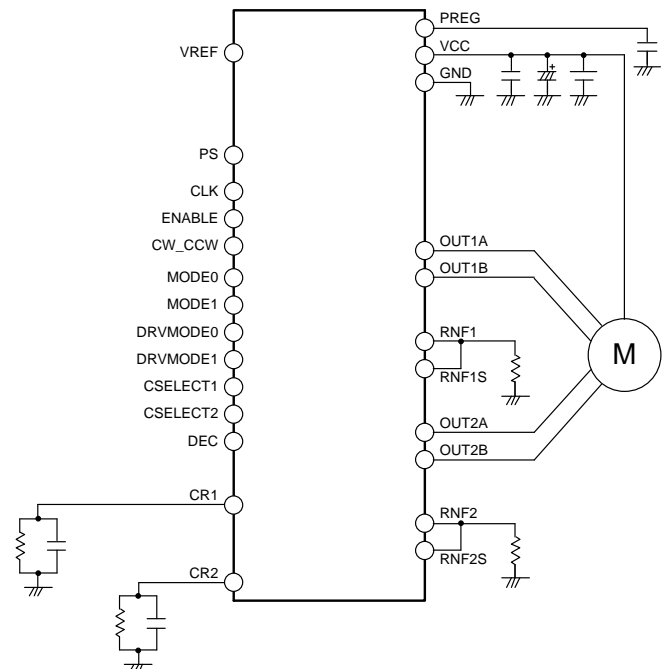

Pin Configuration

[TOP VIEW]

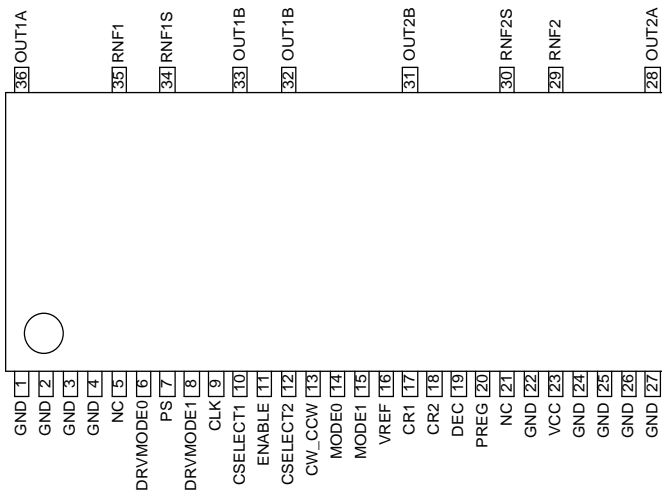

Block Diagram

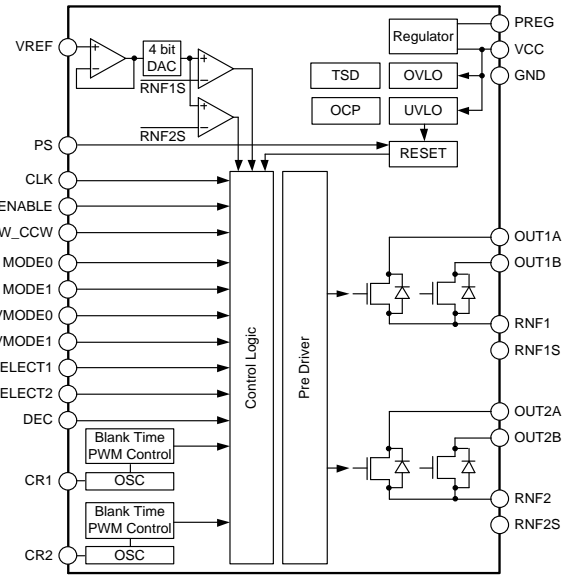

Pin Description

Pin No.	Pin Name	Function	Pin No.	Pin Name	Function
1	GND	Ground pin	28	OUT2A	Open drain output pin
2	GND	Ground pin	-	-	-
3	GND	Ground pin	-	-	-
4	GND	Ground pin	-	-	-
5	NC	No connection	29	RNF2	Connection pin of resistor for output current detection
6	DRVMODE0	Input interface setting pin	-	-	-
7	PS	Power save pin	30	RNF2S	Input pin of current detection comparator
8	DRVMODE1	Input interface setting pin	-	-	-
9	CLK	CLK input pin for advancing the electrical angle	-	-	-
10	CSELECT1	ID setting pin	-	-	-
11	ENABLE	Output enable pin	31	OUT2B	Open drain output pin
12	CSELECT2	ID setting pin	-	-	-
13	CW_CCW	Motor rotating direction setting pin	-	-	-
14	MODE0	Motor excitation mode setting pin	-	-	-
15	MODE1	Motor excitation mode setting pin	-	-	-
16	VREF	Output current value setting pin	32	OUT1B	Open drain output pin
17	CR1	Connection pin of CR for setting chopping frequency	-	-	-
18	CR2	Connection pin of CR for setting chopping frequency	33	OUT1A	Open drain output pin
19	DEC	Synchronous rectification setting pin	-	-	-
20	PREG	IC internal voltage	-	-	-
21	NC	No connection	34	RNF1S	Input pin of current detection comparator
22	GND	Ground pin	-	-	-
23	VCC	Power supply pin	35	RNF1	Connection pin of resistor for output current detection
24	GND	Ground pin	-	-	-
25	GND	Ground pin	-	-	-
26	GND	Ground pin	-	-	-
27	GND	Ground pin	36	OUT1A	Open drain output pin

Function Explanation

1 **VCC: Power supply pin**

Motor's drive current is flowing in it, so please connect it in such a way that the wire is thick & short and has low impedance. VCC voltage may have great fluctuation, so please connect the bypass capacitor (100 μF to 470 μF) as close as possible to the pin. Adjust in such a way that the VCC voltage is stable. Please increase the capacitance if needed, especially when large current or motors that have great back electromotive force are used.

In addition, to reduce the power supply's impedance in wide frequency bandwidth, parallel connection of multi-layered ceramic capacitor (0.01 μF to 0.1 μF) is recommended. Extreme care must be observed to make sure that the VCC voltage does not exceed the rating even for a moment.

Moreover, there is a built-in clamp device in the output pin to prevent electrostatic destruction. If sudden pulse or surge voltage of more than the maximum absolute rating is applied, the clamp device operates which can result to destruction. Please be sure to not exceed the maximum absolute rating. It is effective to mount a Zener diode with maximum absolute rating. Also, diode is inserted between VCC pin and GND pin to prevent electrostatic destruction. If reverse voltage is applied between VCC pin and GND pin, there is a danger of IC destruction so please be careful.

2 **GND: Ground pin**

In order to reduce the noise caused by switching current and to stabilize the internal reference voltage of IC, please connect it in such a way that the wiring impedance from this pin is made as low as possible to achieve the lowest electrical potential under any operating condition.

Design the pattern so that it does not have a common impedance with other GND patterns.

3 **PREG: IC internal voltage**

This is the regulator output pin for driving output transistors. PREG voltage may have great fluctuation, so please connect the capacitor (0.1 μF) as close as possible to the pin. Adjust in such a way that the PREG voltage is stable.

4 **PS: Power save pin**

The PS pin can make circuit in STANDBY state and make motor output OPEN.

In STANDBY state, translator circuit is RESET (initialized) and electrical angle is initialized.

When PS = L to H, be careful because there is a delay of 40 μs (Max) before it is returned from STANDBY state to normal state and the motor output becomes ACTIVE (Refer to [P.14](#)). During this time, the motor output logic is not fixed.

PS	Status
L	STANDBY (RESET)
H	ACTIVE

The electrical angle (initial electrical angle) of each excitation mode immediately after RESET is as follows (Refer to [P.15, 16](#)).

Excitation Mode	Initial Electrical Angle
FULL STEP A	45°
HALF STEP A	45°
HALF STEP B	45°
QUARTER STEP	45°

5 **ENABLE: Output enable pin**

When using CLK-IN Drive Mode, turn off forcibly all the output transistors (motor output is open).

The translator circuit stop and the electrical angle doesn't advance in the section of ENABLE = L. Because CLK input is blocked.

However, during excitation modes (MODE0, MODE1) switch within the interval of ENABLE = L, as ENABLE = L to H is reset, the new mode upon switch will be applied for excitation (Refer to [P.18](#)).

ENABLE	Motor Output
L	OPEN(electrical angle maintained)
H	ACTIVE

When using 3-wire Serial Communication Mode, connect this pin to GND.

6 **CLK: CLK input pin for advancing the electrical angle**

Trigger is CLK's rising edge. The Electrical angle advances by one for each CLK input. Motor's misstep will occur if noise is picked up at the CLK pin, so design the pattern in such a way that there is no noise plunging in.

Function Explanation - continued

7 CW\_CCW: Motor rotating direction setting pin

When using CLK-IN Drive Mode, sets the motor's rotating direction.  
Change in setting is reflected at the CLK rising edge immediately after the change in setting (Refer to P.17).

CW_CCW	Rotating Direction
L	Clockwise (CH2's current is outputted with a phase lag of 90° in regard to CH1's current)
H	Counter Clockwise(CH2's current is outputted with a phase lead of 90° in regard to CH1's current)

When using 3-wire Serial Communication Mode, input CSB signal (Refer to P.11).

8 MODE0, MODE1: Motor excitation mode setting pin

Set the motor excitation mode.

MODE0	MODE1	Excitation Mode
L	L	FULL STEP A
H	L	HALF STEP A
L	H	HALF STEP B
H	H	QUARTER STEP

Refer to the P.15, 16 for the timing chart and motor torque vector of various excitation modes.

The excitation mode setting changes regardless of CLK signal (Refer to P.18).

When using 3-wire Serial Communication Mode, input SCL signal to MODE0 pin and SDA signal to MODE1 pin (Refer to P.11).

9 DEC: Synchronous rectification setting pin

In current decay mode, set the synchronous rectification (Refer to P.10).

DEC	Setting
L	No synchronous rectification
H	Synchronous rectification implemented

10 DRVMODE0, DRVMODE1: Input interface setting pin

Set the input interface mode.

DRVMODE0	DRVMODE1	Input Interface
L	L	CLK-IN Drive Mode
L	H	3-wire Serial Communication Mode A
H	X <sup>(Note 1)</sup>	3-wire Serial Communication Mode B

Fix the logic of DRVMODEx pin at PS = L state or before UVLO release, and do not change during operation.

Refer to P.11 for the various input interface mode.

(Note 1) x = L or H

11 CSELECT1, CSELECT2: ID setting pin

Set the IC's ID.

When using 3-wire Serial Communication Mode, you can choose which IC to send the serial data to.

CSELECT1	CSELECT2	ID
L	L	No.0
M	L	No.1
H	L	No.2
L	M	No.3
M	M	No.4
H	M	No.5
L	H	No.6

CSELECTx <sup>(Note 2)</sup> Input Voltage [V]	Logic
0 to 0.7	L
1.2 to 1.9	M
2.4 to 5.0	H

Fix the logic of CSELECTx pin at PS = L state or before UVLO release, and do not change during operation.

(Note 2) x = 1, 2

12 OUT1A, OUT1B, OUT2A, OUT2B: Open drain output pin

Motor's drive current is flowing in this pin, design the wire in such a way that it is thick enough, as short as possible and has low impedance. It is also effective to add a Schottky diode when the output has large positive and negative fluctuations when large current is used, for example when the back electromotive voltage is large.

## Function Explanation – continued

**13 RNF1, RNF2: Connection pin of resistor for output current detection**

Insert current detecting resistor of 0.13 Ω to 0.28 Ω between RNF<sub>x</sub><sup>(Note 1)</sup> and GND.

The power consumption of current detecting resistor (W) can be calculated by the motor output current value (I<sub>OUT</sub>) and resistance for current detecting resistor (R<sub>RNF</sub>).

$$W = I_{OUT}^2 \times R_{RNF} \quad [W]$$

Where:

W : is the power consumption of current detecting resistor [W]  
 I<sub>OUT</sub> : is the motor output current value [A]  
 R<sub>RNF</sub> : is the current-detecting resistor [Ω]

To avoid exceeding the rated power consumption of the resistor, consider its power consumption. In addition, design it in such a way that it has low impedance and does not have a common impedance with other GND patterns because motor's drive current flows through this pattern from the RNF<sub>x</sub> pin to current-detecting resistor to GND. Do not exceed the rating because there is the possibility of circuits' malfunction etc., if the RNF<sub>x</sub> voltage has exceeded the maximum rating (1.0 V). Moreover, be careful because if the RNF<sub>x</sub> pin is shorted to GND, large current flows without normal PWM constant current control, then there is the danger that OCP or TSD will operate. If the RNF<sub>x</sub> pin is open, then there is the possibility of such malfunction as output current does not flow either, so do not let it open.

(Note 1) x = 1, 2

**14 RNF1S, RNF2S: Input pin of current detection comparator**

In this IC, the RNF<sub>x</sub>S<sup>(Note 2)</sup> pin, which is the input pin of current detection comparator, is independently arranged in order to decrease the lowering of the current-detecting accuracy caused by the wire impedance inside the IC of the RNF<sub>x</sub><sup>(Note 2)</sup> pin. Therefore, be sure to connect the RNF<sub>x</sub> pin and the RNF<sub>x</sub>S pin together when using the device in the case of PWM constant current control. In addition, impedance of board pattern between the RNF<sub>x</sub> pin and the current-detecting resistor can decrease accuracy, so connect RNF<sub>x</sub>S pattern in such a way it is connected near the current-detecting resistor so accuracy can be increased. Moreover, design the pattern in such a way that there is no noise plunging in. In addition, be careful because if the RNF<sub>x</sub>S pin is shorted to GND, large current flows without normal PWM constant current control and, then there is the danger that OCP or TSD will operate.

(Note 2) x = 1 or 2

**15 VREF: Output current value setting pin**

This is the pin to set the output current value. It can be set by VREF voltage (V<sub>VREF</sub>) and current-detecting resistor (R<sub>RNF</sub>).

$$I_{OUT} = \frac{V_{VREF}}{5} \times \frac{1}{R_{RNF}} \quad [A]$$

Where:

I<sub>OUT</sub> : is the output current. [A]  
 V<sub>VREF</sub> : is the voltage of output current value-setting pin. [V]  
 R<sub>RNF</sub> : is the current-detecting resistor. [Ω]

Avoid using the VREF pin open because input becomes unsettled, and the VREF voltage increases, and then there is the possibility of such malfunctions as the setting current increases and a large current flows etc. Keep to the input voltage range because if the voltage of above 3 V is applied on the VREF pin, then there is also the danger that a large current flows in the output and so OCP or TSD will operate. Besides, take into consideration the outflow current (2 μA (Max)) if the input used is a resistor divider. The minimum current, which can be controlled by VREF voltage, is determined by motor coil's L, R values and minimum ON time because there is a minimum ON time in PWM drive.

**16 CR1, CR2: Connection pin of CR for setting chopping frequency**

This is the pin to set the chopping frequency of output. Connect the external C (220 pF to 8000 pF) and R (2 kΩ to 400 kΩ) between this pin and GND. Refer to [P.9](#).

Make the connection from external components to GND in such a way that there is no common impedance with other GND patterns. In addition, keep the pattern away from steep pulses like square waves, etc. and there is no noise plunging in. When CR<sub>x</sub><sup>(Note 3)</sup> pin is open or it is biased from the outside, it is not possible to control normal PWM constant current, so if it is used in PWM constant current control, always put both C and R parts.

(Note 3) x = 1, 2

**17 NC: No connection**

This pin is unconnected electrically with IC internal circuit.

## Protection Circuits

### 1 Thermal Shutdown (TSD)

This IC has a built-in thermal shutdown circuit for thermal protection. When the IC's controller chip temperature rises 150 °C (Typ) or more, the motor output becomes OPEN. Also, when the temperature returns to 125 °C (Typ) or less, it automatically returns to normal operation. However, even when TSD is in operation, if heat is continued to be added externally, heat overdrive can lead to destruction.

It is not possible to follow the output transistor junction temperature rising rapidly because it is a controller chip that monitors the temperature and it is likely not to function effectively.

### 2 Over Current Protection (OCP)

This IC has a built-in over current protection circuit as a provision against destruction when VCC-motor output is shorted. This circuit latches the motor output to OPEN condition when the  $RNF_x$ <sup>(Note 1)</sup> voltage exceeds 2.5 V (Typ) for 4 μs (Typ). It returns with power reactivation or a reset by the PS pin. The over current protection circuit's only aim is to prevent the destruction of the IC from irregular situations such as motor output shorts, and is not meant to be used as protection or security for the set. Therefore, sets should not be designed to take into account this circuit's functions. After OCP operating, if irregular situations continue and the return by power reactivation or a reset by the PS pin, then OCP operates repeatedly and the IC may generate heat or otherwise deteriorate. When the L value of the wiring is great due to the wiring being long, the motor outputs are shorted each other or VCC-motor output or motor output-GND is shorted., if the output pin voltage jumps up and the absolute maximum values can be exceeded after the over current has flowed, there is a possibility of destruction. Also, when current which is the output current rating or more and the OCP detection current or less flows, the IC can heat up to  $T_{jmax} = 150$  °C exceeds and can deteriorate, so current which or more the output rating should not be applied.

(Note 1) x = 1, 2

### 3 Under Voltage Lock Out (UVLO)

This IC has a built-in under voltage lock out function to prevent false operation such as IC output during power supply under voltage is low. When the applied voltage to the VCC pin goes 5 V (Typ) or less, the motor output is set to OPEN. This switching voltage has a 1 V (Typ) hysteresis to prevent false operation by noise etc. Be aware that this circuit does not operate during power save mode. Also, the electrical angle is reset when the UVLO circuit operates.

### 4 Over Voltage Lock Out (OVLO)

This IC has a built-in over voltage lock out function to protect the IC output and the motor during power supply over voltage. When the applied voltage to the VCC pin goes 32 V (Typ) or more, the motor output is set to OPEN. This switching voltage has a 1 V (Typ) hysteresis and a 4 μs (Typ) mask time to prevent false operation by noise etc. Although this over voltage locked out circuit is built-in, there is a possibility of destruction if the absolute maximum value for power supply voltage is exceeded. Therefore, the absolute maximum value should not be exceeded. Be aware that this circuit does not operate during power save mode.

### 5 Protects against malfunction when power supply is disconnected (Ghost Supply Prevention Function)

If a control signal<sup>(Note 2)</sup> is input when there is no power supplied to this IC, there is a function which prevents a malfunction where voltage is supplied to power supply of this IC or other IC in the set via the electrostatic destruction prevention diode from these input pins to the  $VCC_x$ . Therefore, there is no malfunction of the circuit even when voltage is supplied to these input pins while there is no power supply.

(Note 2) control signal = PS, ENABLE, CLK, CW\_CCW, MODE0, MODE1, DEC, DRVMODE0, DRVMODE1, CSELECT1, CSELECT2, VREF

### 6 Operation Under Strong Electromagnetic Field

The IC is not designed for using in the presence of strong electromagnetic field. Be sure to confirm that no malfunction is found when using the IC in a strong electromagnetic field.

**Absolute Maximum Ratings**

Item	Symbol	Rated Value	Unit
Supply Voltage Range	V <sub>CC</sub>	-0.2 to +36.0	V
Input Voltage Range for Control Pin <sup>(Note 1)</sup>	V <sub>IN</sub>	-0.2 to +5.5	V
RNF <sub>x</sub> <sup>(Note 2)</sup> Maximum Voltage	V <sub>RNF</sub>	1.0	V
Output Voltage	V <sub>OUT</sub>	100	V
Output Current (Continuous)	I <sub>OUT</sub>	3.0 <sup>(Note 3)</sup>	A/Phase
Output Current (Peak Value)	I <sub>OUTPEAK</sub>	3.5 <sup>(Note 3)</sup>	A/Phase
Storage Temperature Range	T <sub>stg</sub>	-55 to +150	°C
Maximum Junction Temperature	T <sub>jmax</sub>	+150	°C

(Note 1) Input Voltage for Control Pin = PS, ENABLE, CLK, CW\_CCW, MODE0, MODE1, DEC, DRVMODE0, DRVMODE1, CSELECT1, CSELECT2, VREF

(Note 2) x = 1, 2

(Note 3) Do not exceed T<sub>jmax</sub> = 150 °C.

**Caution 1:** Operating the IC over the absolute maximum ratings may damage the IC. The damage can either be a short circuit between pins or an open circuit between pins and the internal circuitry. Therefore, it is important to consider circuit protection measures, such as adding a fuse, in case the IC is operated over the absolute maximum ratings.

**Caution 2:** Should by any chance the maximum junction temperature rating be exceeded the rise in temperature of the chip may result in deterioration of the properties of the chip. In case of exceeding this absolute maximum rating, design a PCB with thermal resistance taken into consideration by increasing board size and copper area so as not to exceed the maximum junction temperature rating.

**Recommended Operating Condition**

Item	Symbol	Min	Typ	Max	Unit
Supply Voltage	V <sub>CC</sub>	8	24	28	V
Operating Temperature	T <sub>opr</sub>	-25	+25	+85	°C
Maximum Output Current (Continuous)	I <sub>OUT</sub>	-	-	2.4 <sup>(Note 4)</sup>	A/Phase

(Note 4) Do not exceed T<sub>jmax</sub> = 150 °C.

**Thermal Resistance** <sup>(Note 5)</sup>

Parameter	Symbol	Thermal Resistance (Typ)		Unit
		1s <sup>(Note 7)</sup>	2s2p <sup>(Note 8)</sup>	
SSOP-A54_36A				
Junction to Ambient	θ <sub>JA</sub>	74.8	52.1	°C/W
Junction to Top Characterization Parameter <sup>(Note 6)</sup>	Ψ <sub>JT</sub>	39	32	°C/W

(Note 5) Based on JESD51-2A (Still-Air), using a BM6343AFS-Z Chip.

(Note 6) The thermal characterization parameter to report the difference between junction temperature and the temperature at the top center of the outside surface of the component package.

(Note 7) Using a PCB board based on JESD51-3.

(Note 8) Using a PCB board based on JESD51-7.

Layer Number of Measurement Board	Material	Board Size
Single	FR-4	114.3 mm x 76.2 mm x 1.57 mmt

Top	
Copper Pattern	Thickness
Footprints and Traces	70 μm

Layer Number of Measurement Board	Material	Board Size
4 Layers	FR-4	114.3 mm x 76.2 mm x 1.6 mmt

Top		2 Internal Layers		Bottom	
Copper Pattern	Thickness	Copper Pattern	Thickness	Copper Pattern	Thickness
Footprints and Traces	70 μm	74.2 mm x 74.2 mm	35 μm	74.2 mm x 74.2 mm	70 μm

Electrical Characteristics (Unless otherwise specified  $V_{CC} = 24\text{ V}$ ,  $T_a = 25\text{ }^\circ\text{C}$ )

Item	Symbol	Specification			Unit	Condition
		Min	Typ	Max		
<b>[Whole]</b>						
Circuit Current at Standby	$I_{CCST}$	-	0	10	$\mu\text{A}$	PS = L
Circuit Current	$I_{CC}$	-	5.0	6.5	mA	PS = H, VREF = 3 V
<b>[Control Logic Input<sup>(Note 1)</sup>]</b>						
H-level Input Voltage	$V_{INH}$	2.0	-	-	V	
L-level Input Voltage	$V_{INL}$	-	-	0.8	V	
H-level Input Current	$I_{INH}$	35	50	100	$\mu\text{A}$	$V_{IN} = 5\text{ V}$
L-level Input Current	$I_{INL}$	-10	0	-	$\mu\text{A}$	$V_{IN} = 0\text{ V}$
<b>[Output<sup>(Note 2)</sup>]</b>						
Output ON Resistance	$R_{ON}$	-	0.10	0.20	$\Omega$	$I_{OUT} = 1.0\text{ A}$
Output Leak Current	$I_{LEAK}$	-	-	10	$\mu\text{A}$	
<b>[Current Control]</b>						
RNF <sub>x</sub> S <sup>(Note 3)</sup> Input Current	$I_{RNFS}$	-2.0	-0.1	-	$\mu\text{A}$	$RNF_{xS} = 0\text{ V}$
VREF Input Current	$I_{VREF}$	-2.0	-0.1	-	$\mu\text{A}$	$V_{REF} = 0\text{ V}$
VREF Input Voltage Range	$V_{VREF}$	0	-	3.0	V	
Minimum ON Time (Cancel time)	$t_{ONMIN}$	1.0	2.6	5.2	$\mu\text{s}$	$C = 1000\text{ pF}$ , $R = 39\text{ k}\Omega$
Comparator Threshold	$V_{CTH}$	0.579	0.600	0.621	V	$V_{REF} = 3\text{ V}$

(Note 1) Control Logic Input = PS, ENABLE, CLK, CW\_CCW, MODE0, MODE1, DEC, DRVMODE0, DRVMODE1

(Note 2) Output = OUT1A, OUT1B, OUT2A, OUT2B

(Note 3) x = 1, 2



**PWM Constant Current Control**

**1 Current Control Operation**

When the output transistor is turned on, the output current increases. The output current is converted to voltage due to the connected external resistance to the RNF<sub>x</sub><sup>(Note 1)</sup> pin. When the voltage on the RNF<sub>x</sub> pin reaches the voltage value set by the VREF input voltage, the current limit comparator operates and enters current decay mode. Output turns on again after changing the CR Timer to charge state from discharge state. The process repeats itself with chopping period t<sub>CHOP</sub>.  
 (Note 1) x = 1, 2

**2 Noise Cancel Function**

In order to avoid misdetection of current detection comparator due to RNF spike noise that may occur when the output turns ON, the IC has the minimum ON time t<sub>ONMIN</sub> (Cancel Time). The current detection is invalid from the output transistor turned on to t<sub>ONMIN</sub>. This allows for constant-current drive without the need for an external filter.

**3 CR Timer**

The external capacitor and resistor connected to the CR<sub>x</sub><sup>(Note 2)</sup> pin is repeatedly charged and discharged between the V<sub>CRH</sub> and V<sub>CRL</sub> levels. The CR<sub>x</sub> pin voltage decides in IC and it is V<sub>CRL</sub> = 0.4 V, V<sub>CRH</sub> = 0.8 V respectively. The output of the current detection comparator is masked while charging from V<sub>CRL</sub> to V<sub>CRH</sub>. As mentioned above, this period defines the minimum ON-time. When the output current reaches the current limit, the IC enters decay mode and the CR<sub>x</sub> pin begins discharging once the voltage reaches V<sub>CRH</sub>. The CR continues to discharge during this period until it reaches V<sub>CRL</sub>, at which point the IC output is switched back ON. The current output and the CR pin begin charging simultaneously. The CR charge time (t<sub>ONMIN</sub>) and discharge time (t<sub>DISCHARGE</sub>) are set by external components, according to the following formulas.

$$t_{ONMIN} \cong C \times \frac{R' \times R}{R' + R} \times \ln \left( \frac{V_{CR} - 0.4}{V_{CR} - 0.8} \right) \text{ [s]}$$

- t<sub>ONMIN</sub> : is the minimum ON-time. [s]
- C : is the capacitance of the CR Pin. [F]
- R : is the resistance of the CR Pin. [Ω]
- R' : is the CR<sub>x</sub> Pin internal impedance 5 kΩ (Typ)
- V<sub>CR</sub> : is the CR<sub>x</sub> Pin voltage. [V]

$$V_{CR} = V \times \frac{R}{R' + R} \text{ [V]}$$

- V : is the internal regulator voltage 5 V (Typ).

$$t_{DISCHARGE} \cong C \times R \times \ln \left( \frac{0.8 + \alpha}{0.4} \right) \text{ [s]}$$

- t<sub>DISCHARGE</sub> : is the CR discharge time. [s]
- α : Refer to the right graph.

(Note 2) x = 1, 2

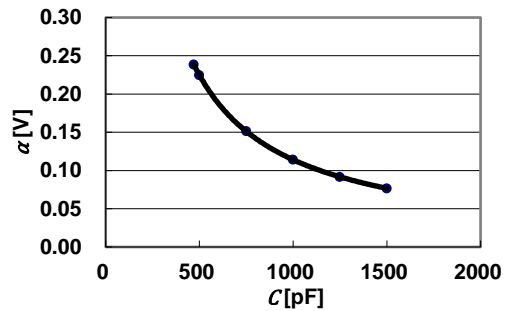

Figure 1. CR Coefficient for Calculation of Discharge Time

PWM Constant Current Control – continued

3 CR Timer – continued

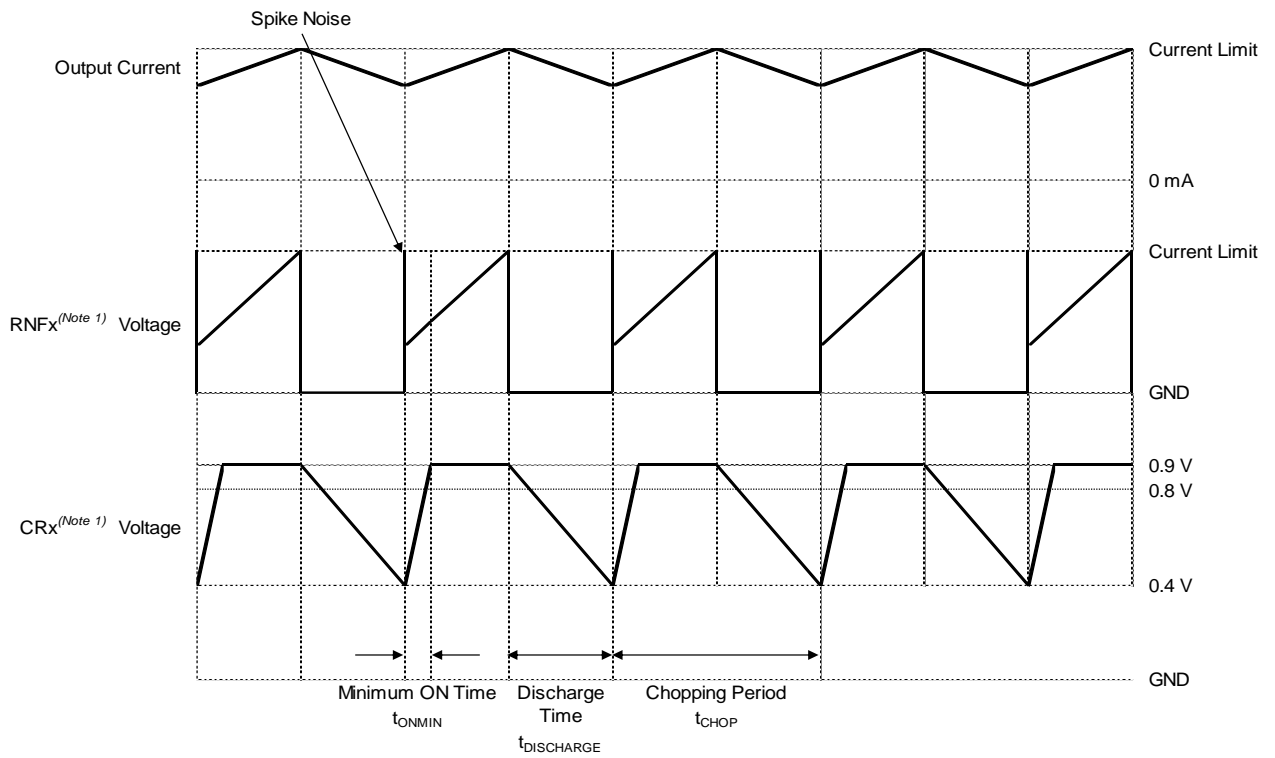

Figure 2. Timing Chart of CRx Voltage, RNFX Voltage and Output Current

Attach a resistor of at least 2 kΩ to the CRx Pin (2 kΩ to 400 kΩ recommended) as lower values may keep the CRx from reaching the V<sub>CRH</sub> voltage level. A capacitor in the range of 220 pF to 8000 pF is also recommended. Using capacitance value of several thousand pF or more, however, the noise-masking period (t<sub>ONMIN</sub>) also increases, and there is a risk that the output current may exceed the setting value due to the internal L and R components of the output motor coil. Also, ensure that the chopping period t<sub>CHOP</sub> is not set longer than necessary, as doing so will increase the output ripple, thereby decreasing the average output current and yielding lower output rotation efficiency. Select optimal value so that motor drive sound, and distortion of output current waveform can be minimized.

(Note 1) x = 1, 2

4 Synchronous Rectification

PWM Constant Current Control can be optionally set the synchronous rectification by the logic of DEC pin. The following diagrams show the state of each output transistor and the regenerative current path during the current decay for each setting.

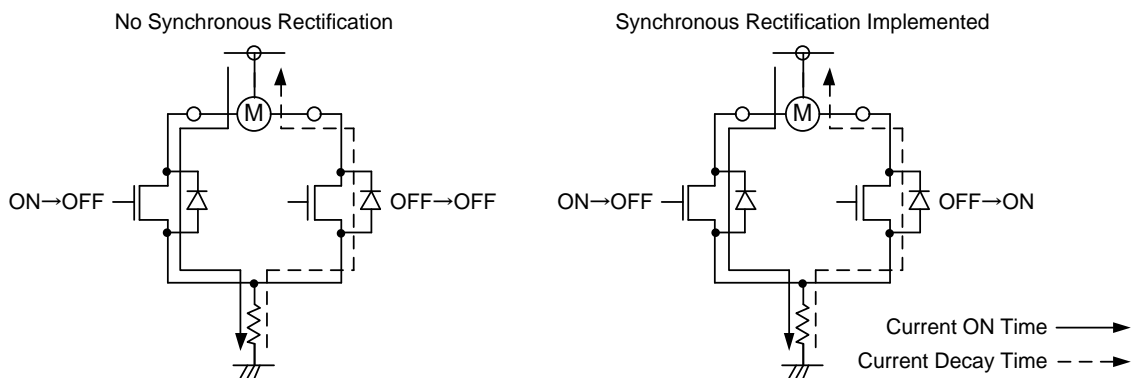

Figure 3. The State of Each Transistor and The Regenerative Current Path during The Current Decay

### 3-wire Serial Communication

This chip is equipped with 8-bit 3-wire Serial Communication Mode as an input interface for controlling the drive of the motor. In L section of the CSB pin, the SDI logic is sent to the internal shift register at the rising edge of SCL pin. The input order of serial data is D7→D0. The input waveform image is shown below.

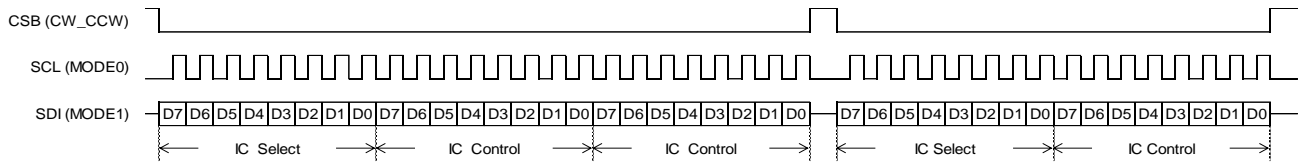
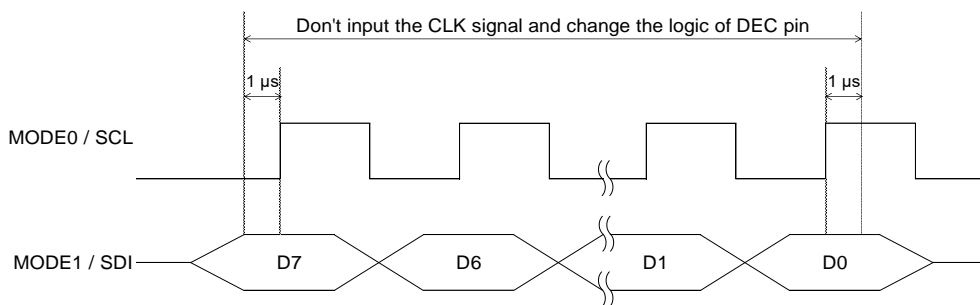

Figure 4. 3-wire Serial Communication Input Waveform

IC selection is performed with 8 bits immediately after the falling of CSB, and IC is controlled with the subsequent 8 bits. If CSB starts in the middle of 8-bit cycle, the data for that cycle will not be transmitted. In IC select, the IC can be selected by setting the ID of IC to which the signal is wanted to be sent to "1". The IC control signal is sent only to IC for which the selected ID is set. Also, multiple IDs can be selected.

In addition, during 8 bit serial signal, don't input the CLK signal and change the logic of DEC pin at the timing shown in the below.



#### 1 3-wire Serial Communication Mode A

When DRVMODE0 = L and DRVMODE1 = H, the 3-wire Serial Communication Mode A is enabled (Refer to P.4). The input bit assignment is shown below.

bit	IC Select	IC Control	
	ID	Parameter	Initial
D0	No.0	MODE0	0
D1	No.1	MODE1	0
D2	No.2	CW_CCW	0
D3	No.3	ENABLE	0
D4	No.4	-	-
D5	No.5	-	-
D6	No.6	-	-
D7	-	-	-

\* Use D7 at 0.

\* Use D4~D7 at 0.

The IC installed translator circuit will operate (Refer to P.14). For details of each parameter in IC control, refer to P.3.

3-wire Serial Communication – continued

2 3-wire Communication Mode B

When DRVMODE0 = H, the 3-wire Serial Communication Mode B is enabled (Refer to P.4).  
The input bit assignment is shown below.

bit	IC Select	IC Control	
	ID	Parameter	Initial
D0	No.0	I02	0
D1	No.1	I12	0
D2	No.2	I01	0
D3	No.3	I11	0
D4	No.4	PHASE1	0
D5	No.5	PHASE2	0
D6	No.6	-	-
D7	-	-	-

\* Use D7 at 0.

\* Use D6, D7 at 0.

The IC installed translator circuit will not operate.

2.1 PHASE1, PHASE2 /Phase Switching Parameter

These are parameters that determine the output logic.

PHASE1	PHASE2	OUT1A	OUT1B	OUT2A	OUT2B
0	0	0	1	0	1
1	0	1	0	0	1
0	1	0	1	1	0
1	1	1	0	1	0

2.2 I01, I11, I02, I12 /VREF Division Ratio Setting Parameter

The VREF pin voltage is inputted to 2-bit DAC inside the IC, and is a parameter that sets the division ratio of 2-bit DAC.

Set 1Ch output by I01 and I11, and 2Ch output by I02 and I12.

I0x <sup>(Note 1)</sup>	I1x <sup>(Note 1)</sup>	Output Current Level [%]
0	0	100
1	0	67
0	1	33
1	1	0

If (I0x, I1x) = (H, H), set each motor output to OPEN.

(Note 1) x = 1, 2

3-wire Serial Communication – continued

3 Input Timing

The write timing of the serial port is shown below.

Signal	Parameters	Symbol	Ratings			Unit
			Min	Typ	Max	
CSB	CSB "H" Pulse Width	$t_{CHW}$	400	-	-	ns
	CSB-SCL Time	$t_{CSS}$ (Note 2)	200	-	-	ns
		$t_{CSH}$ (Note 3)	200	-	-	ns
SCL	Serial Clock Cycle	$t_{SCYC}$	1000	-	-	ns
	SCL "H" Pulse Width	$t_{SHW}$	500	-	-	ns
	SCL "L" Pulse Width	$t_{SLW}$	500	-	-	ns
	SCL Rising Edge Time	$t_r$	-	-	50	ns
	SCL Falling Edge Time	$t_f$	-	-	50	ns
SDI	Data Setup Time	$t_{SDS}$	250	-	-	ns
	Data Hold Time	$t_{SDH}$	250	-	-	ns

(Note 2) The time from CSB falling edge to the first SCL rising edge.

(Note 3) The time from last SCL rising edge to the CSB rising edge.

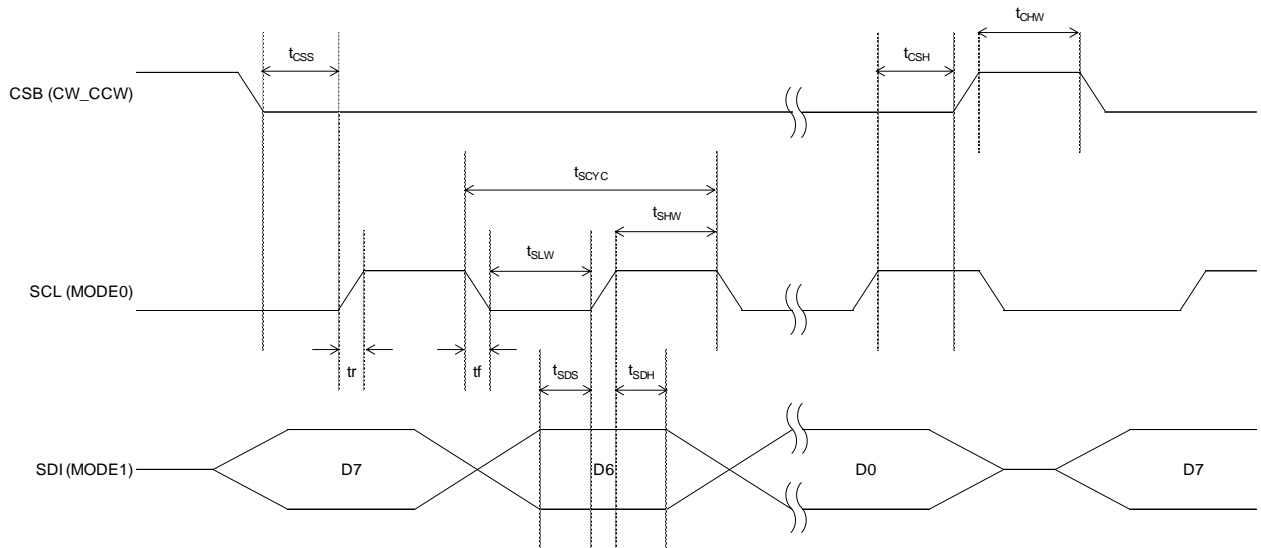

Figure 5. Input Timing

**Translator Circuit**

This series has a built in translator circuit and can drive stepping motor.  
The operation of the translator circuit in CLK-IN Drive Mode or 3-wire Serial Communication Mode A is described as below.

**1 Reset Operation**

The translator circuit is initialized by Power ON Reset Function and the PS pin.

**1.1 Initializing Operation when Power Supply is Turned On**

**1.1.1 If Power Supply is Turned On at PS = L (Use this sequence as a general rule)**

When power supply is turned on, the Power ON Reset Function is initialized and operates the IC, but as long as it is PS = L, the motor output is the OPEN state. After power supply is turned on, the motor output becomes ACTIVE state by changing PS = L to H, and the excitation is started at the initial electrical angle. But at the time of PS = L to H, it returns from the STANDBY state to the normal state and there is a delay of 40 μs (Max) until the motor output has become the ACTIVE state.

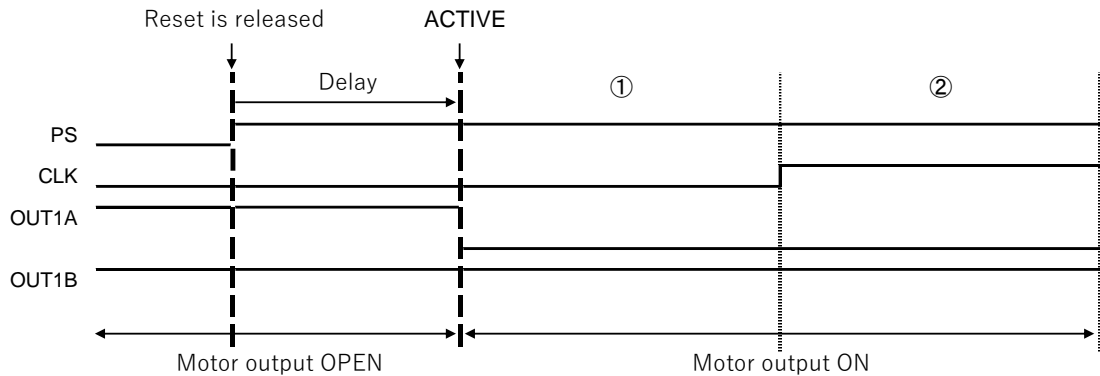

**1.1.2 If Power Supply is Turned On at PS = H**

When power supply is turned on and the Power ON Reset Function in IC operates, and be initialized before the motor output becomes the ACTIVE state during ENABLE = H, and the excitation is started at the initial electrical angle.

**1.2 Initializing Operation during Motor Operating**

Enter a reset signal to the PS pin to initialize the translator circuit during motor operation. (Refer to P.17) But at the time of PS = L to H, it returns from the STANDBY state to the normal state and there is a delay of 40 μs (Max) until the motor output has become the ACTIVE state, so within this delay interval there is no phase advance operation even if CLK is inputted.

**2 Control Input Timing**

Shown below is the operation of the translator circuit at the rising edge of CLK signal. If you disobey this timing and input, then there is the possibility that the translator circuit does not operate as expected. In addition, at the time of PS = L to H, it returns from the STANDBY state to the normal state and there is a delay of 40 μs (Max) until the motor output has become the ACTIVE state, so within this delay interval there is no phase advance operation even if CLK is inputted.

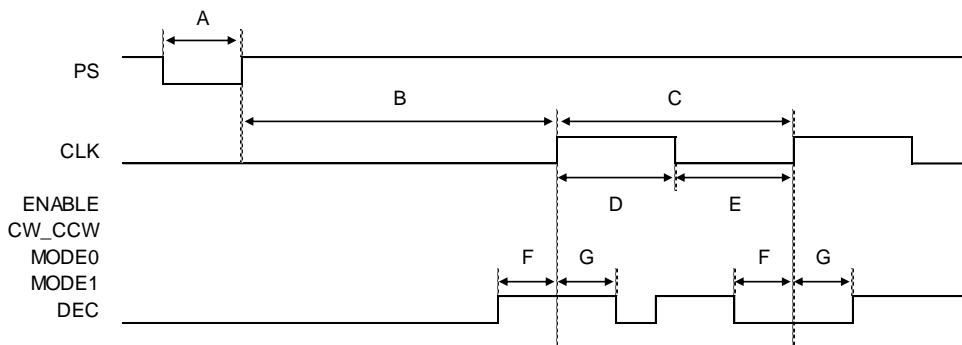

- A: PS Minimum Input Pulse Width ... 20 μs
- B: PS Rising Edge to CLK Rising Edge Input Possible Maximum Delay Time ... 40 μs
- C: CLK Minimum Period ... 4 μs
- D: CLK Minimum Input H Pulse Width ... 2 μs
- E: CLK Minimum Input L Pulse Width ... 2 μs
- F: ENABLE, CW\_CCW, MODE0, MODE1, DEC Set-Up Time ... 1 μs
- G: ENABLE, CW\_CCW, MODE0, MODE1, DEC Hold Time ... 1 μs

Translator Circuit – continued

3 FULL STEP (MODE0 = L, MODE1 = L, CW\_CCW = L, ENABLE = H)

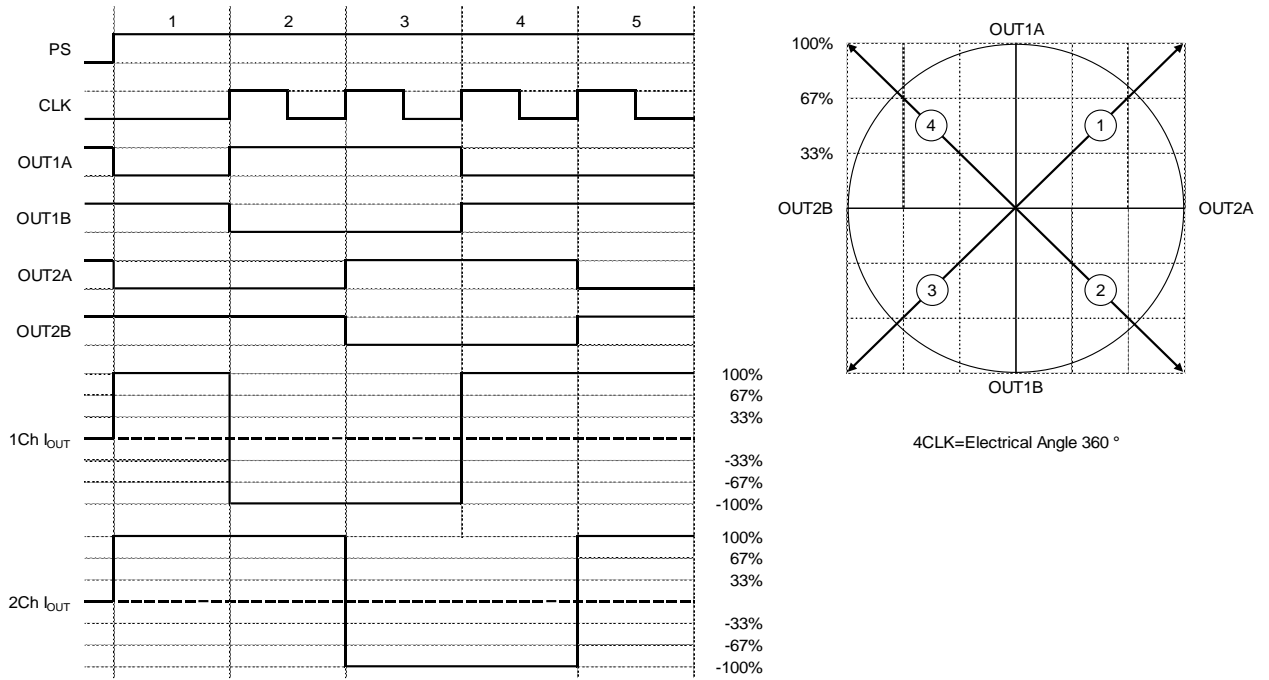

4 HALF STEP A (MODE0 = H, MODE1 = L, CW\_CCW = L, ENABLE = H)

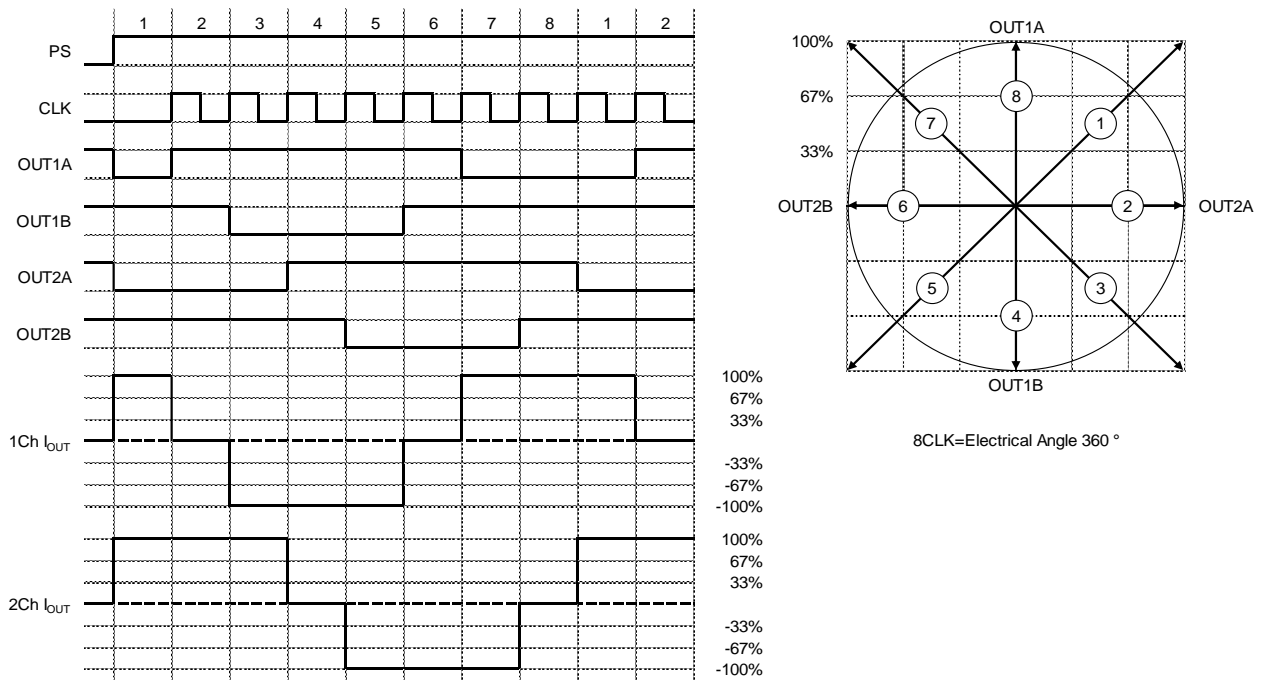

Translator Circuit – continued

5 HALF STEP B (MODE0 = L, MODE1 = H, CW\_CCW = L, ENABLE = H)

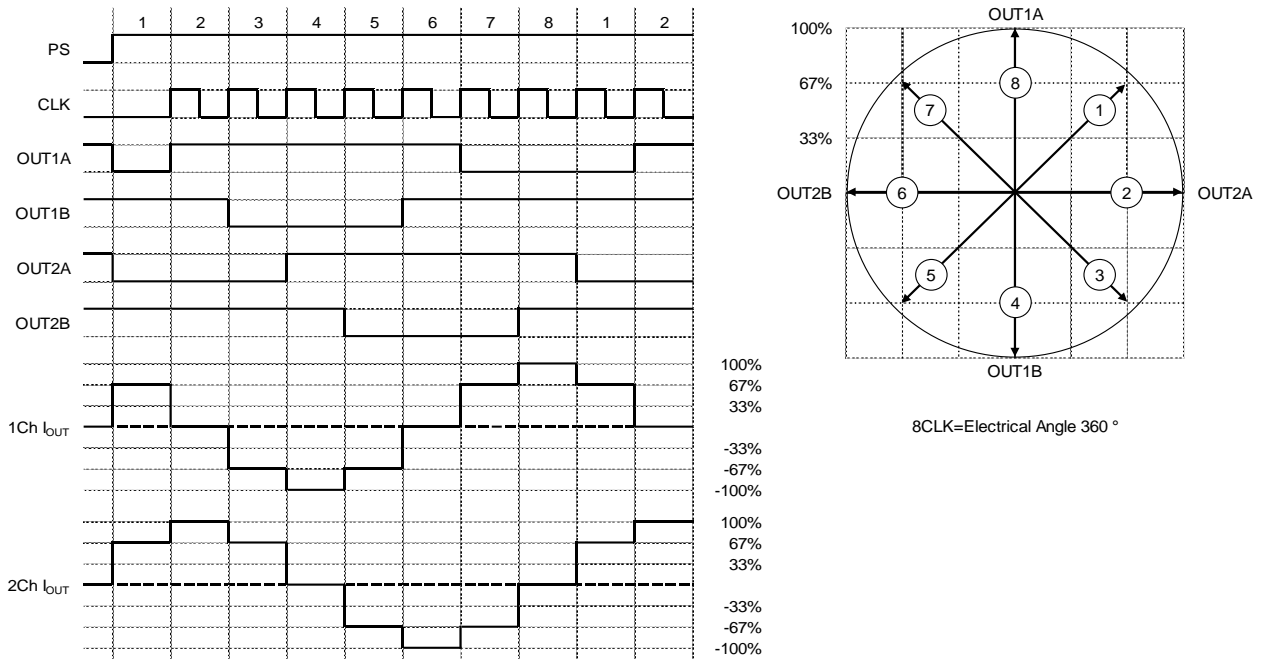

6 QUARTER STEP (MODE0 = H, MODE1 = H, CW\_CCW = L, ENABLE = H)

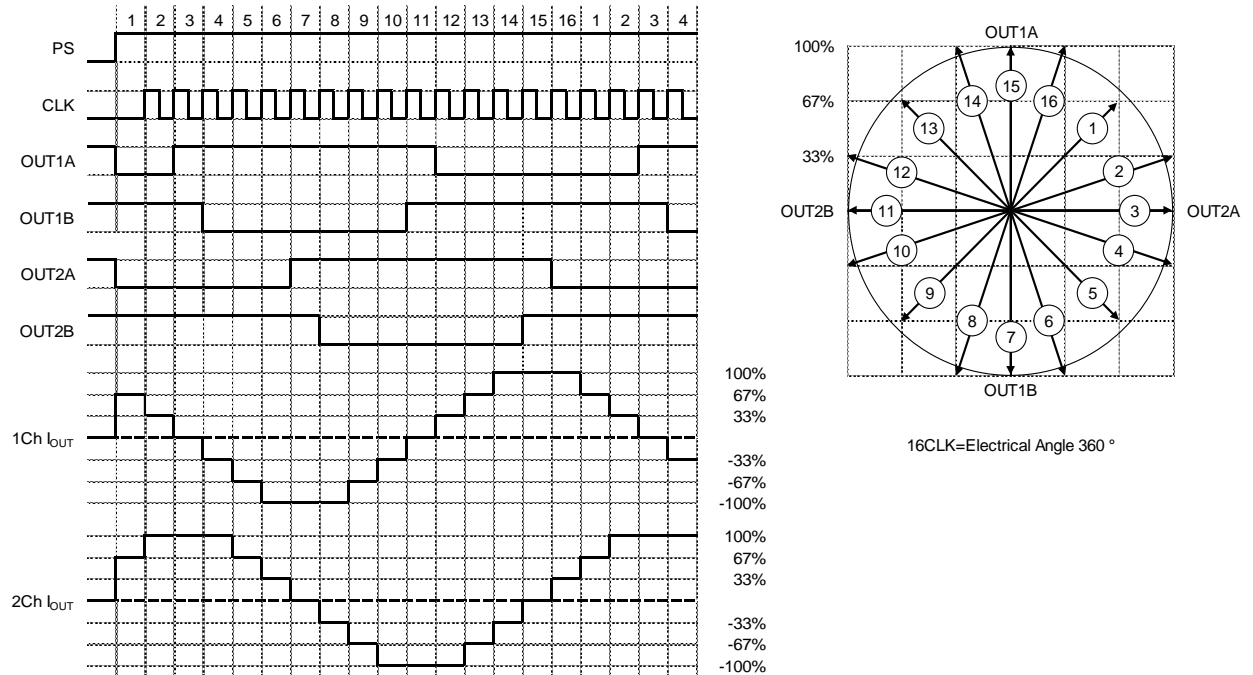



Translator Circuit – continued

7 Reset Timing Chart (FULL STEP, MODE0 = L, MODE1 = L, CW\_CCW = L, ENABLE = H)

To reset the translator circuit during motor operation regardless of the other input signals, enter the PS pin input to L. At this time, IC internal circuit enters the STANDBY mode, and makes the motor output OPEN.

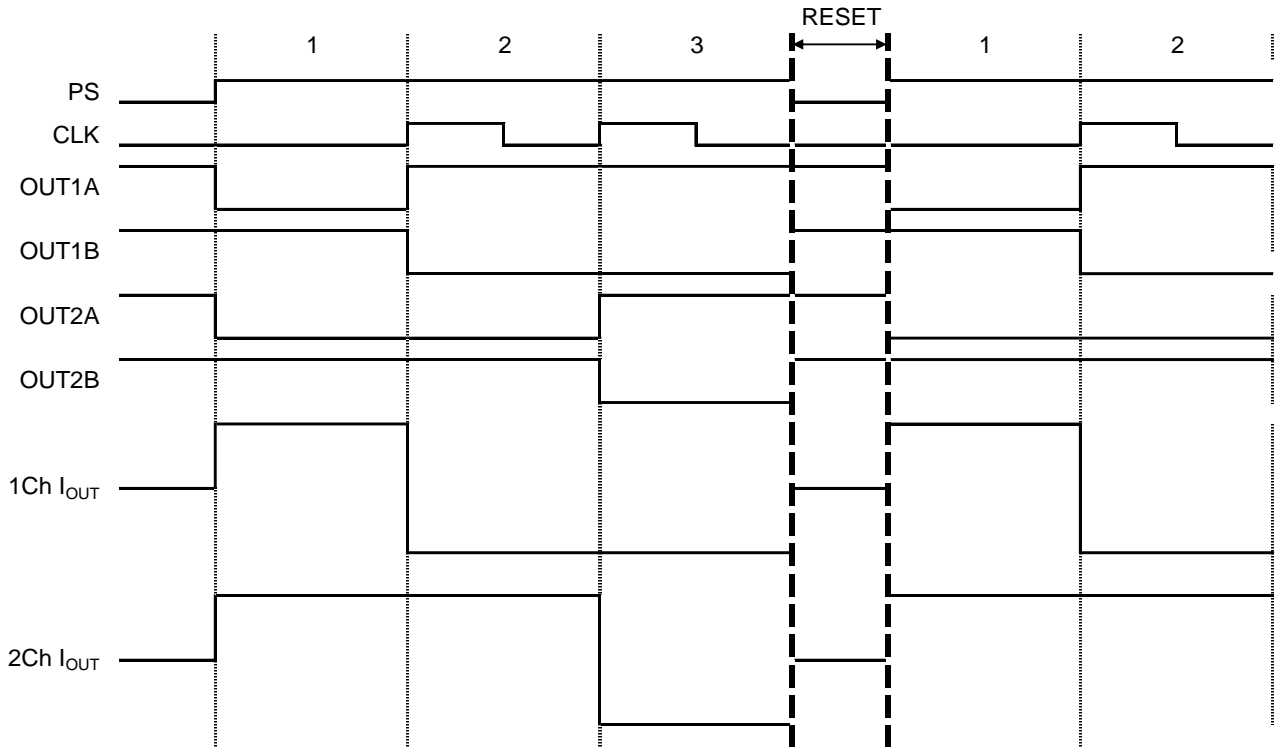

8 CW\_CCW Switch Timing Chart (FULL STEP, MODE0 = L, MODE1 = L, ENABLE = H)

The switch of CW\_CCW is reflected by the rising edge of CLK that comes immediately after CW\_CCW signal has changed. However, depending on the state of operation of the motor at the time of switching, the motor cannot follow even if the control on driver IC corresponds. There are possibilities of step-out and mistake step in motor, so evaluate the sequence of the switch enough.

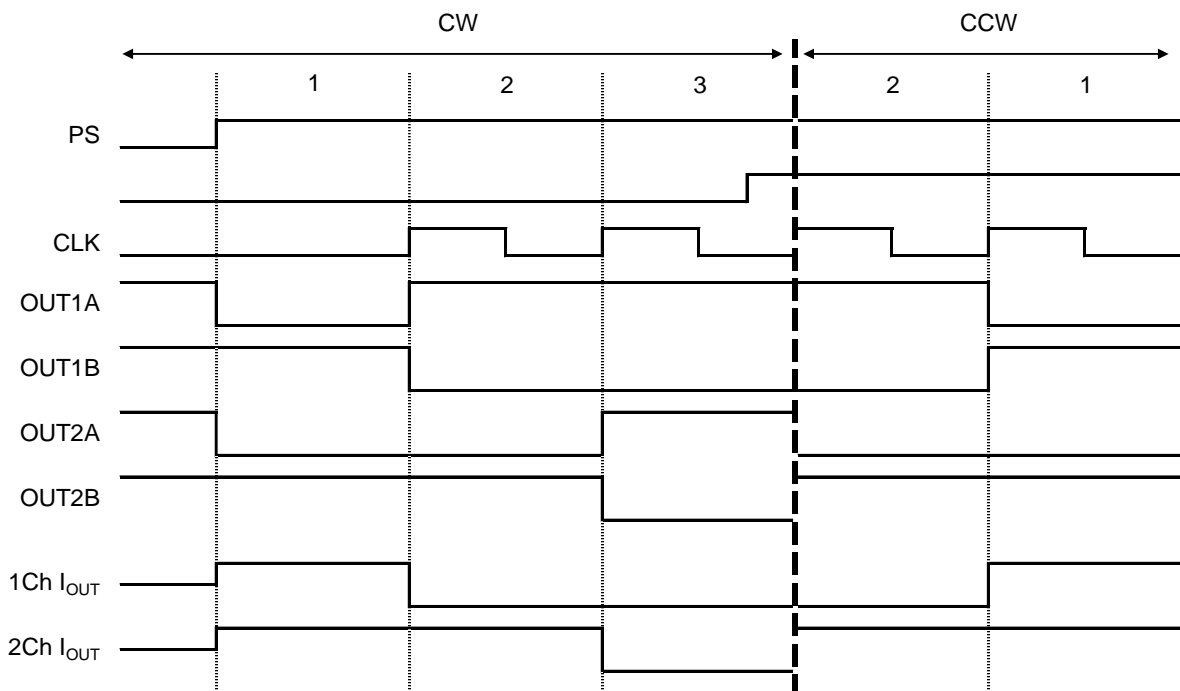

Translator Circuit – continued

9 ENABLE Switch Timing Chart (FULL STEP, MODE0 = L, MODE1 = L,)

The switch of the ENABLE signal is reflected by the change in the ENABLE signal with regardless of other input signals. The translator circuit stop and the electrical angle doesn't advance in the section of ENABLE = L. Because the output for motor is OPEN and CLK input is blocked. When ENABLE = L to H, the output state returns immediately to the last state before the input of ENABLE = L. Excitation mode (MODE0, MODE1) also switches within ENABLE = L interval. Where excitation mode switched within ENABLE = L interval, restoring of ENABLE = L to H was done in the excitation mode after switch.

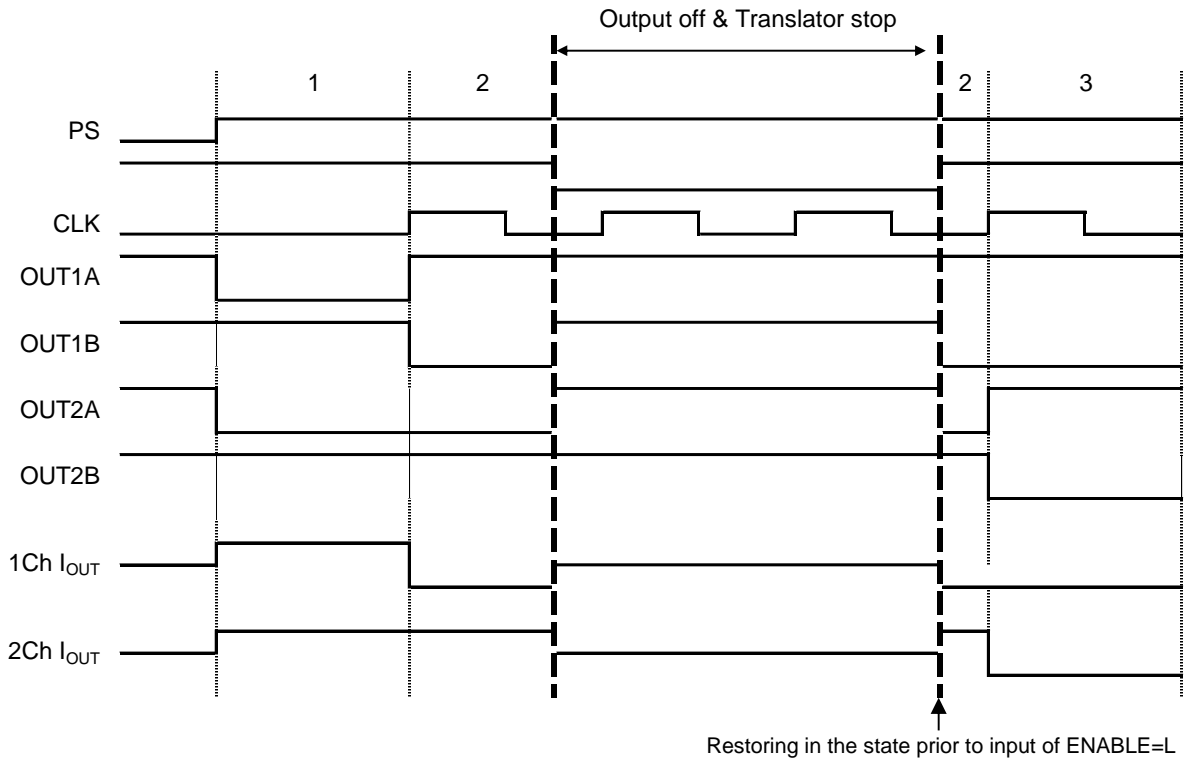

10 About the Switch of the Motor Excitation Mode

The switch of the excitation mode can be done with regardless of the CLK signal at the same time as changing of the signal MODE0 and MODE1. The following built-in function can prevent motor out-of-step caused by discrepancies of torque vector of transitional excitations during switch between excitation modes. Depending on the state of operation of the motor at the switch the motor cannot follow even if the control on driver IC side is correspondent and there are possibilities of step-out and mistake step in motor. Therefore, switch sequence shall be evaluated sufficiently before any decision.

11 Cautions of Bidirectional Switch of CW\_CCW and Excitation Modes (MODE0, MODE1)

As shown in the figure below, the area between the end of reset discharge (PS = L to H) and beginning of the first CLK signal input is defined as interval A, while the area until the end of the first CLK signal input is defined as interval B.

Interval A => For CW\_CCW, no limitation is applied on switch of excitation mode.

Interval B => In CLK1 period, or within ENABLE = L interval, CW\_CCW and excitation mode can't be switched together. Violation of this restriction may lead to false step (with one extra leading phase) or out-of-step. Therefore, in case that CW\_CCW and excitation modes are switched simultaneously, the PS pin must be input with reset signal. Then start to operate in interval A before carrying out such bidirectional switch.

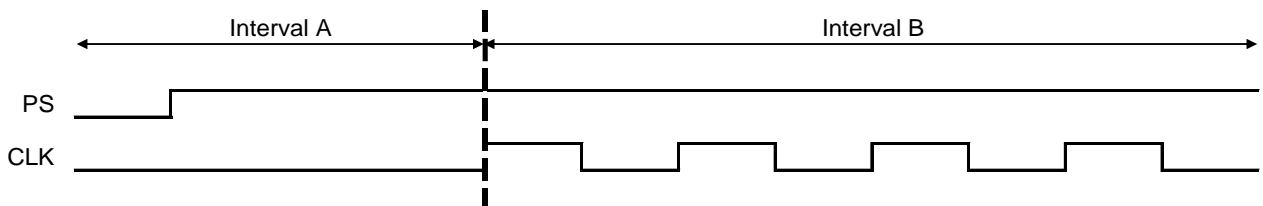

**Power Dissipation**

In consideration of the IC's power consumption (W), thermal resistance (°C/W), and ambient temperature (Ta), confirm that the IC's chip temperature Tj is not over 150 °C. When Tj = 150 °C is exceeded, the functions as a semiconductor do not operate and problems such as parasitism and leaks occur. Constant use under these circumstances leads to deterioration and eventually destruction of the IC. Tjmax = 150 °C must be strictly obeyed under all circumstances.

**Thermal Calculation**

The IC's consumed power can be estimated roughly with the power supply voltage (Vcc), circuit current (Icc), output ON resistance (RON) and motor output current value (IOUT).

The calculation method during FULL STEP drive (No synchronous rectification) mode is shown here:

$$W_{VCC} = V_{CC} \times I_{CC} \text{ [W]}$$

Where:

- W<sub>VCC</sub> : Is the consumed power of the V<sub>CC</sub> [W]
- V<sub>CC</sub> : Is the power supply voltage. [V]
- I<sub>CC</sub> : Is the circuit current. [A]

$$W_{DMOS} = W_{ON} + W_{DECAY} \text{ [W]}$$

$$W_{ON} = R_{ON} \times I_{OUT}^2 \times 2 \times on\_duty \text{ [W]}$$

$$W_{DECAY} = Vf \times I_{OUT} \times 2 \times (1 - on\_duty) \text{ [W]}$$

Where:

- W<sub>DMOS</sub> : is the consumed power of the output DMOS. [W]
- W<sub>ON</sub> : is the consumed power during output ON. [W]
- W<sub>DECAY</sub> : is the consumed power during current decay. [W]
- R<sub>ON</sub> : is the N-channel DMOS ON-resistance. [Ω]
- I<sub>OUT</sub> : is the motor output current value. [A]
- on\_duty : PWM on duty =  $t_{ON} / t_{CHOP}$

t<sub>ON</sub> varies depending on the L and R values of the motor coil and the current set value. Confirm by actual measurement, or make an approximate calculation.

t<sub>CHOP</sub> is the chopping period, which depends on the CRx<sup>(Note 1)</sup> pin. Refer to [P.9](#) for details.

(Note 1) x = 1, 2

IC Number	Nch DMOS ON Resistance R <sub>ON</sub> [Ω] (Typ)
BM6343AFS-Z	0.10

$$W_{total} = W_{VCC} + W_{DMOS} \text{ [W]}$$

$$Tj = Ta + \theta ja \times W_{total} \text{ [°C]}$$

Where:

- W<sub>total</sub> : is the consumed total power of IC. [W]
- Tj : is the junction temperature. [°C]
- Ta : is the ambient temperature. [°C]
- θja : is the thermal resistance value. [°C/W]

However, the thermal resistance value θja [°C/W] differs greatly depending on circuit board conditions. The calculated values above are only theoretical. For actual thermal design, perform sufficient thermal evaluation for the application board used, and create the thermal design with enough margin not to exceed Tjmax = 150 °C.

Application Example

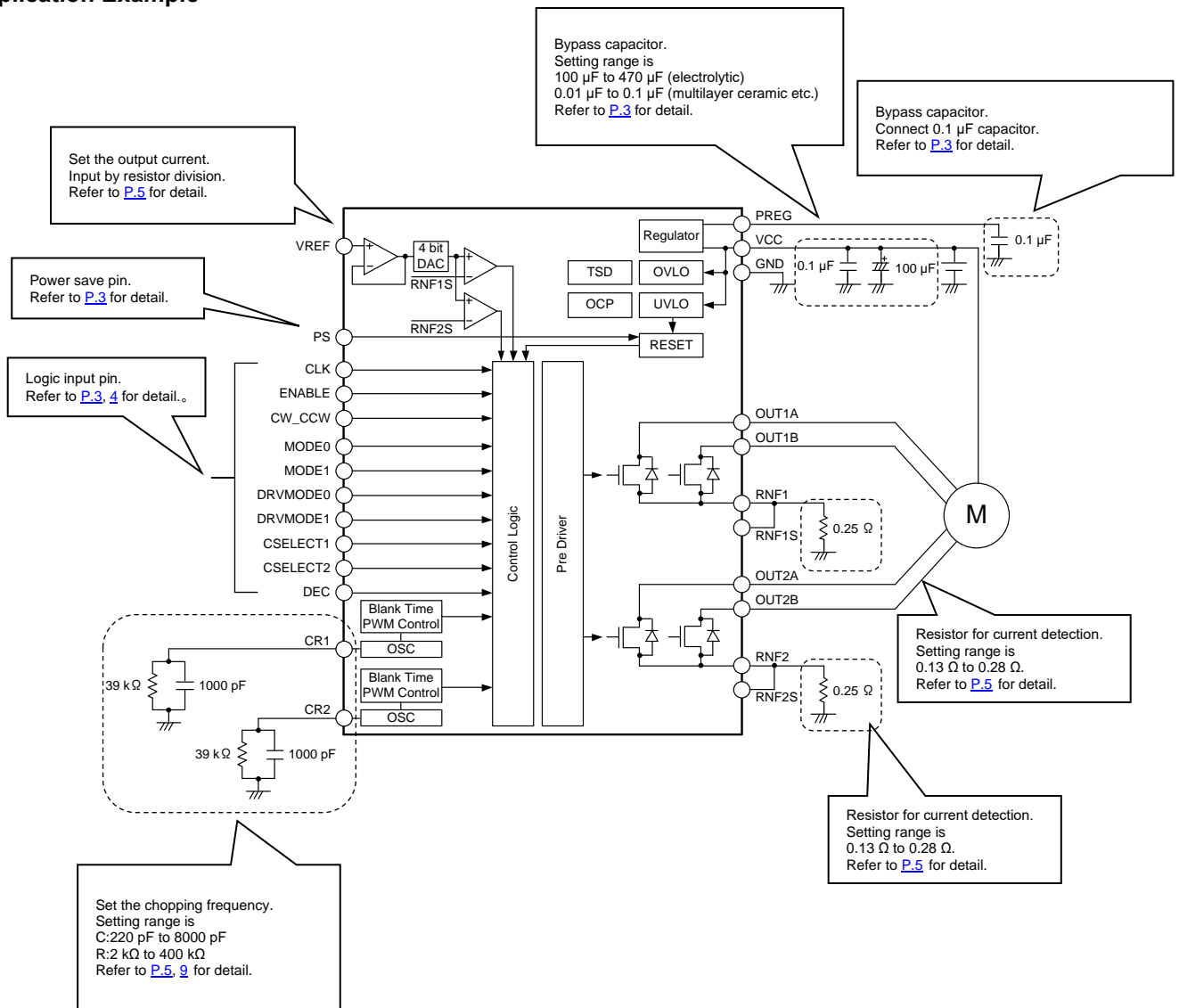

I/O Equivalence Circuit

Pin No.	Pin Name	Equivalence Circuit	Pin No.	Pin Name	Equivalence Circuit		
7	PS		16	VREF			
11	ENABLE						
9	CLK						
13	CW_CCW						
14	MODE0						
15	MODE1						
19	DEC						
6	DRVMODE0						
8	DRVMODE1						
10	CSELECT1		36	OUT1A			
						33	OUT1B
						28	OUT2A
						31	OUT2B
						35	RNF1
						29	RNF2
12	CSELECT2						
34	RNF1S		17	CR1			
						30	RNF2S
18	CR2						

## Operational Notes

### 1 Reverse Connection of Power Supply

Connecting the power supply in reverse polarity can damage the IC. Take precautions against reverse polarity when connecting the power supply, such as mounting an external diode between the power supply and the IC's power supply pins.

### 2 Power Supply Lines

Design the PCB layout pattern to provide low impedance supply lines. Furthermore, connect a capacitor to ground at all power supply pins. Consider the effect of temperature and aging on the capacitance value when using electrolytic capacitors.

### 3 Ground Voltage

Ensure that no pins are at a voltage below that of the ground pin at any time, even during transient condition.

### 4 Ground Wiring Pattern

When using both small-signal and large-current ground traces, the two ground traces should be routed separately but connected to a single ground at the reference point of the application board to avoid fluctuations in the small-signal ground caused by large currents. Also ensure that the ground traces of external components do not cause variations on the ground voltage. The ground lines must be as short and thick as possible to reduce line impedance.

### 5 Recommended Operating Conditions

The function and operation of the IC are guaranteed within the range specified by the recommended operating conditions. The characteristic values are guaranteed only under the conditions of each item specified by the electrical characteristics.

### 6 Inrush Current

When power is first supplied to the IC, it is possible that the internal logic may be unstable and inrush current may flow instantaneously due to the internal powering sequence and delays, especially if the IC has more than one power supply. Therefore, give special consideration to power coupling capacitance, power wiring, width of ground wiring, and routing of connections.

### 7 Testing on Application Boards

When testing the IC on an application board, connecting a capacitor directly to a low-impedance output pin may subject the IC to stress. Always discharge capacitors completely after each process or step. The IC's power supply should always be turned off completely before connecting or removing it from the test setup during the inspection process. To prevent damage from static discharge, ground the IC during assembly and use similar precautions during transport and storage.

### 8 Inter-pin Short and Mounting Errors

Ensure that the direction and position are correct when mounting the IC on the PCB. Incorrect mounting may result in damaging the IC. Avoid nearby pins being shorted to each other especially to ground, power supply and output pin. Inter-pin shorts could be due to many reasons such as metal particles, water droplets (in very humid environment) and unintentional solder bridge deposited in between pins during assembly to name a few.

### 9 Unused Input Pins

Input pins of an IC are often connected to the gate of a MOS transistor. The gate has extremely high impedance and extremely low capacitance. If left unconnected, the electric field from the outside can easily charge it. The small charge acquired in this way is enough to produce a significant effect on the conduction through the transistor and cause unexpected operation of the IC. So unless otherwise specified, unused input pins should be connected to the power supply or ground line.

Operational Notes – continued

10 Regarding the Input Pin of the IC

This monolithic IC contains P+ isolation and P substrate layers between adjacent elements in order to keep them isolated. P-N junctions are formed at the intersection of the P layers with the N layers of other elements, creating a parasitic diode or transistor. For example (refer to figure below):

- When GND > Pin A and GND > Pin B, the P-N junction operates as a parasitic diode.
- When GND > Pin B, the P-N junction operates as a parasitic transistor.

Parasitic diodes inevitably occur in the structure of the IC. The operation of parasitic diodes can result in mutual interference among circuits, operational faults, or physical damage. Therefore, conditions that cause these diodes to operate, such as applying a voltage lower than the GND voltage to an input pin (and thus to the P substrate) should be avoided.

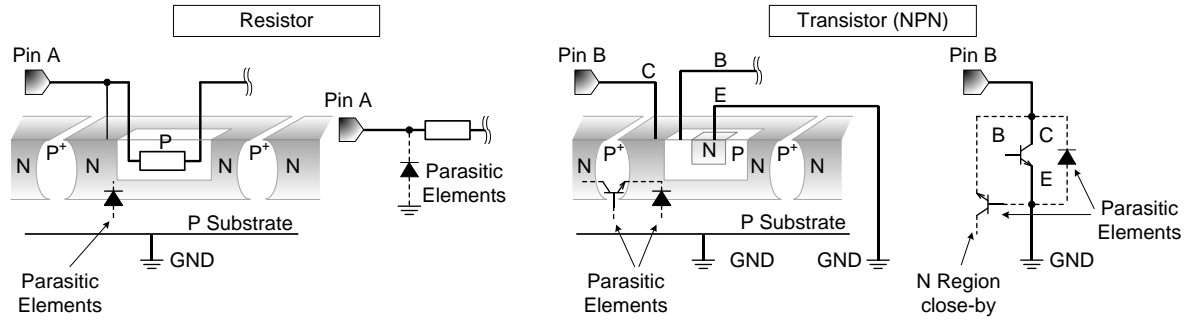

Figure 6. Example of Monolithic IC Structure

11 Ceramic Capacitor

When using a ceramic capacitor, determine a capacitance value considering the change of capacitance with temperature and the decrease in nominal capacitance due to DC bias and others.

12 Thermal Shutdown Circuit (TSD)

This IC has a built-in thermal shutdown circuit that prevents heat damage to the IC. Normal operation should always be within the IC's maximum junction temperature rating. If however the rating is exceeded for a continued period, the junction temperature (Tj) will rise which will activate the TSD circuit that will turn OFF power output pins. When the Tj falls below the TSD threshold, the circuits are automatically restored to normal operation.

Note that the TSD circuit operates in a situation that exceeds the absolute maximum ratings and therefore, under no circumstances, should the TSD circuit be used in a set design or for any purpose other than protecting the IC from heat damage.

13 Over Current Protection Circuit (OCP)

This IC incorporates an integrated overcurrent protection circuit that is activated when the load is shorted. This protection circuit is effective in preventing damage due to sudden and unexpected incidents. However, the IC should not be used in applications characterized by continuous operation or transitioning of the protection circuit.

Ordering Information

B M 6 3 4 3 A F S

Package Type  
FS: SSOP-A54\_36A

Z E 2

Packaging, Forming specification  
Z: Outside assembly  
E2: Embossed tape and reel

Marking Diagram

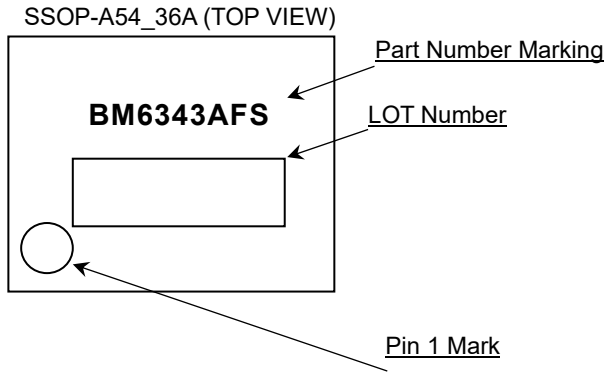



Physical Dimension and Packing Information

Package Name	SSOP-A54_36A
--------------	--------------

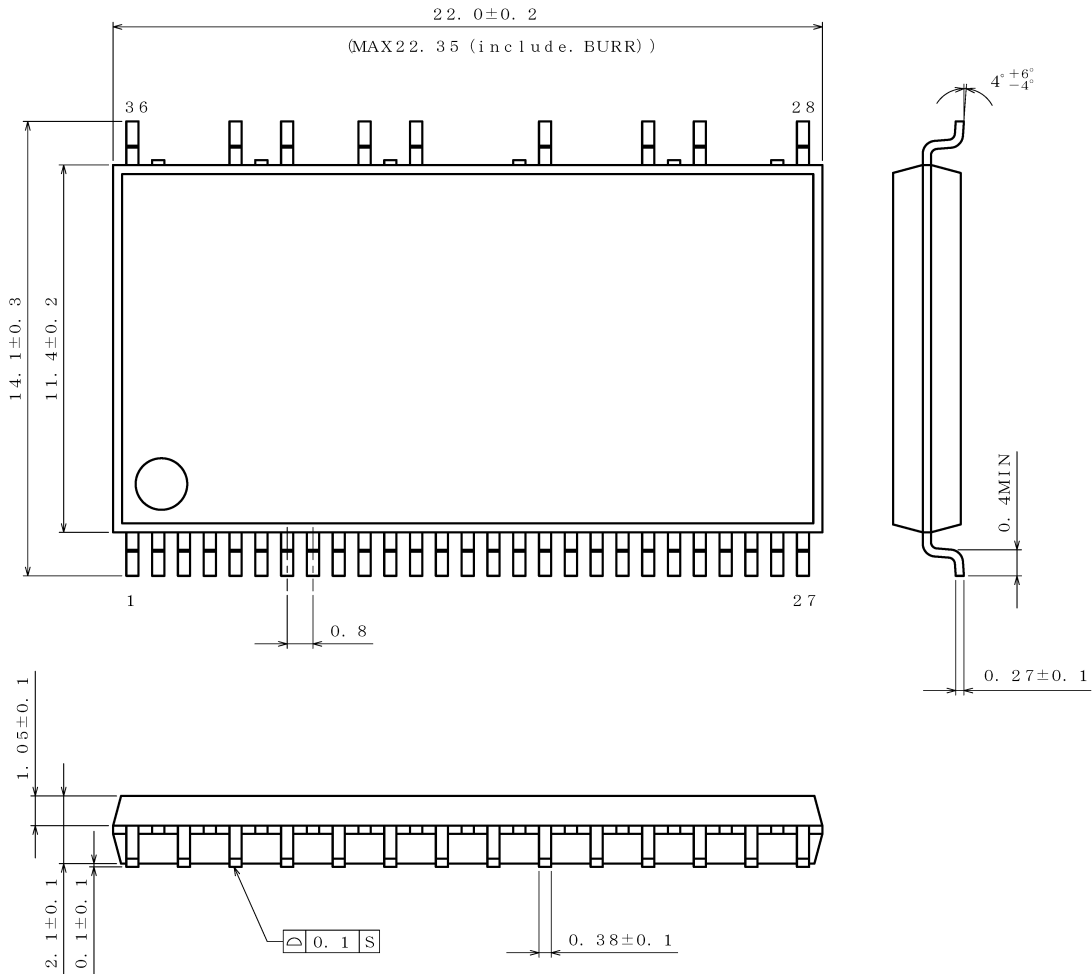

(UNIT : mm)

PKG : SSOP-A54\_36A  
Drawing No. EX001-0087

< Tape and Reel Information >

Tape	Embossed carrier tape
Quantity	1000pcs
Direction of feed	E2 The direction is the pin 1 of product is at the upper left when you hold reel on the left hand and you pull out the tape on the right hand

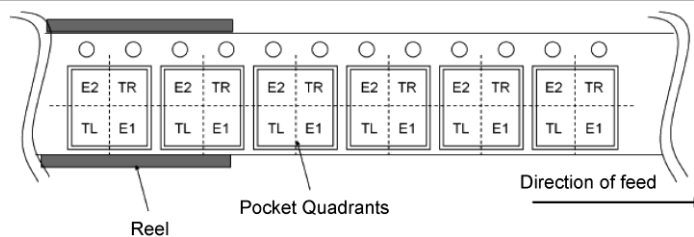

**Revision History**

Date	Revision	Changes
06.Nov.2024	001	New Release

# Notice

## Precaution on using ROHM Products

- Our Products are designed and manufactured for application in ordinary electronic equipment (such as AV equipment, OA equipment, telecommunication equipment, home electronic appliances, amusement equipment, etc.). If you intend to use our Products in devices requiring extremely high reliability (such as medical equipment <sup>(Note 1)</sup>, transport equipment, traffic equipment, aircraft/spacecraft, nuclear power controllers, fuel controllers, car equipment including car accessories, safety devices, etc.) and whose malfunction or failure may cause loss of human life, bodily injury or serious damage to property ("Specific Applications"), please consult with the ROHM sales representative in advance. Unless otherwise agreed in writing by ROHM in advance, ROHM shall not be in any way responsible or liable for any damages, expenses or losses incurred by you or third parties arising from the use of any ROHM's Products for Specific Applications.

(Note1) Medical Equipment Classification of the Specific Applications

JAPAN	USA	EU	CHINA
CLASS III	CLASS III	CLASS II b	CLASS III
CLASS IV		CLASS III	

- ROHM designs and manufactures its Products subject to strict quality control system. However, semiconductor products can fail or malfunction at a certain rate. Please be sure to implement, at your own responsibilities, adequate safety measures including but not limited to fail-safe design against the physical injury, damage to any property, which a failure or malfunction of our Products may cause. The following are examples of safety measures:
  - Installation of protection circuits or other protective devices to improve system safety
  - Installation of redundant circuits to reduce the impact of single or multiple circuit failure
- Our Products are designed and manufactured for use under standard conditions and not under any special or extraordinary environments or conditions, as exemplified below. Accordingly, ROHM shall not be in any way responsible or liable for any damages, expenses or losses arising from the use of any ROHM's Products under any special or extraordinary environments or conditions. If you intend to use our Products under any special or extraordinary environments or conditions (as exemplified below), your independent verification and confirmation of product performance, reliability, etc. prior to use, must be necessary:
  - Use of our Products in any types of liquid, including water, oils, chemicals, and organic solvents
  - Use of our Products outdoors or in places where the Products are exposed to direct sunlight or dust
  - Use of our Products in places where the Products are exposed to sea wind or corrosive gases, including Cl<sub>2</sub>, H<sub>2</sub>S, NH<sub>3</sub>, SO<sub>2</sub>, and NO<sub>2</sub>
  - Use of our Products in places where the Products are exposed to static electricity or electromagnetic waves
  - Use of our Products in proximity to heat-producing components, plastic cords, or other flammable items
  - Sealing or coating our Products with resin or other coating materials
  - Use of our Products without cleaning residue of flux (Exclude cases where no-clean type fluxes is used. However, recommend sufficiently about the residue.) ; or Washing our Products by using water or water-soluble cleaning agents for cleaning residue after soldering
  - Use of the Products in places subject to dew condensation
- The Products are not subject to radiation-proof design.
- Please verify and confirm characteristics of the final or mounted products in using the Products.
- In particular, if a transient load (a large amount of load applied in a short period of time, such as pulse, is applied, confirmation of performance characteristics after on-board mounting is strongly recommended. Avoid applying power exceeding normal rated power; exceeding the power rating under steady-state loading condition may negatively affect product performance and reliability.
- De-rate Power Dissipation depending on ambient temperature. When used in sealed area, confirm that it is the use in the range that does not exceed the maximum junction temperature.
- Confirm that operation temperature is within the specified range described in the product specification.
- ROHM shall not be in any way responsible or liable for failure induced under deviant condition from what is defined in this document.

## Precaution for Mounting / Circuit board design

- When a highly active halogenous (chlorine, bromine, etc.) flux is used, the residue of flux may negatively affect product performance and reliability.
- In principle, the reflow soldering method must be used on a surface-mount products, the flow soldering method must be used on a through hole mount products. If the flow soldering method is preferred on a surface-mount products, please consult with the ROHM representative in advance.

For details, please refer to ROHM Mounting specification

### Precautions Regarding Application Examples and External Circuits

1. If change is made to the constant of an external circuit, please allow a sufficient margin considering variations of the characteristics of the Products and external components, including transient characteristics, as well as static characteristics.
2. You agree that application notes, reference designs, and associated data and information contained in this document are presented only as guidance for Products use. Therefore, in case you use such information, you are solely responsible for it and you must exercise your own independent verification and judgment in the use of such information contained in this document. ROHM shall not be in any way responsible or liable for any damages, expenses or losses incurred by you or third parties arising from the use of such information.

### Precaution for Electrostatic

This Product is electrostatic sensitive product, which may be damaged due to electrostatic discharge. Please take proper caution in your manufacturing process and storage so that voltage exceeding the Products maximum rating will not be applied to Products. Please take special care under dry condition (e.g. Grounding of human body / equipment / solder iron, isolation from charged objects, setting of Ionizer, friction prevention and temperature / humidity control).

### Precaution for Storage / Transportation

1. Product performance and soldered connections may deteriorate if the Products are stored in the places where:
  - [a] the Products are exposed to sea winds or corrosive gases, including Cl<sub>2</sub>, H<sub>2</sub>S, NH<sub>3</sub>, SO<sub>2</sub>, and NO<sub>2</sub>
  - [b] the temperature or humidity exceeds those recommended by ROHM
  - [c] the Products are exposed to direct sunshine or condensation
  - [d] the Products are exposed to high Electrostatic
2. Even under ROHM recommended storage condition, solderability of products out of recommended storage time period may be degraded. It is strongly recommended to confirm solderability before using Products of which storage time is exceeding the recommended storage time period.
3. Store / transport cartons in the correct direction, which is indicated on a carton with a symbol. Otherwise bent leads may occur due to excessive stress applied when dropping of a carton.
4. Use Products within the specified time after opening a humidity barrier bag. Baking is required before using Products of which storage time is exceeding the recommended storage time period.

### Precaution for Product Label

A two-dimensional barcode printed on ROHM Products label is for ROHM's internal use only.

### Precaution for Disposition

When disposing Products please dispose them properly using an authorized industry waste company.

### Precaution for Foreign Exchange and Foreign Trade act

Since concerned goods might be fallen under listed items of export control prescribed by Foreign exchange and Foreign trade act, please consult with ROHM in case of export.

### Precaution Regarding Intellectual Property Rights

1. All information and data including but not limited to application example contained in this document is for reference only. ROHM does not warrant that foregoing information or data will not infringe any intellectual property rights or any other rights of any third party regarding such information or data.
2. ROHM shall not have any obligations where the claims, actions or demands arising from the combination of the Products with other articles such as components, circuits, systems or external equipment (including software).
3. No license, expressly or implied, is granted hereby under any intellectual property rights or other rights of ROHM or any third parties with respect to the Products or the information contained in this document. Provided, however, that ROHM will not assert its intellectual property rights or other rights against you or your customers to the extent necessary to manufacture or sell products containing the Products, subject to the terms and conditions herein.

### Other Precaution

1. This document may not be reprinted or reproduced, in whole or in part, without prior written consent of ROHM.
2. The Products may not be disassembled, converted, modified, reproduced or otherwise changed without prior written consent of ROHM.
3. In no event shall you use in any way whatsoever the Products and the related technical information contained in the Products or this document for any military purposes, including but not limited to, the development of mass-destruction weapons.
4. The proper names of companies or products described in this document are trademarks or registered trademarks of ROHM, its affiliated companies or third parties.

**General Precaution**

1. Before you use our Products, you are requested to carefully read this document and fully understand its contents. ROHM shall not be in any way responsible or liable for failure, malfunction or accident arising from the use of any ROHM's Products against warning, caution or note contained in this document.
2. All information contained in this document is current as of the issuing date and subject to change without any prior notice. Before purchasing or using ROHM's Products, please confirm the latest information with a ROHM sales representative.
3. The information contained in this document is provided on an "as is" basis and ROHM does not warrant that all information contained in this document is accurate and/or error-free. ROHM shall not be in any way responsible or liable for any damages, expenses or losses incurred by you or third parties resulting from inaccuracy or errors of or concerning such information.