

Automotive IPD Series

1ch Low Side Switch IC

BV1LB085FJ-C

Features

- Built-in overcurrent limiting circuit(OCP)
- Built-in thermal shutdown circuit(TSD)
- Built-in active clamp circuit
- Direct control enabled from CMOS logic IC, etc.
- Low On resistance $R_{ON}=85m\Omega$ (Typ)
(when $V_{IN}=5V$, $I_D=0.5A$, $T_j=25^\circ C$)
- Monolithic power management IC with the control block (CMOS) and power MOS FET mounted on a single chip
- AEC-Q100 Qualified (Note 1)
(Note 1) Grade1

Product Summary

On-state resistance ($T_j=25^\circ C$, Typ)	85m Ω
Overcurrent limit ($T_j=25^\circ C$, Typ)	17.5A
Output clamp voltage (Min)	42V
Active clamp energy ($T_j=25^\circ C$)	260mJ

Package
SOP-J8

W(Typ) x D(Typ) x H(Max)
4.90mm x 6.00mm x 1.65mm



General Description

The BV1LB085FJ-C is an automotive 1ch low side switch IC, which has built-in overcurrent limiting circuit, thermal shutdown circuit, and overvoltage (active clamp) protection circuit.

Applications

1ch low side switch for driving resistive, Inductive load, Capacitive load

Block Diagram

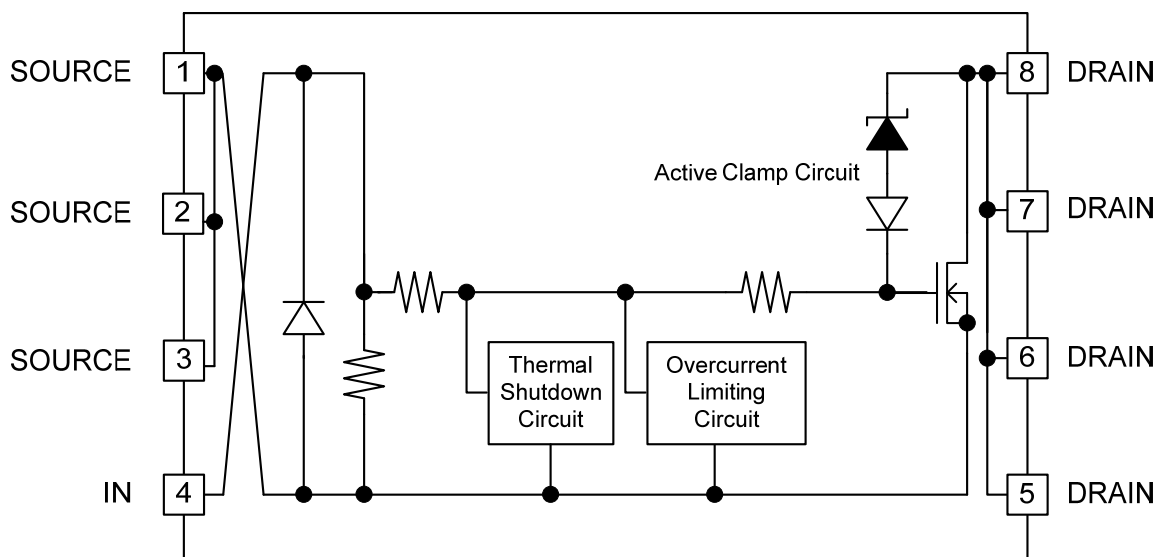

Pin Configurations

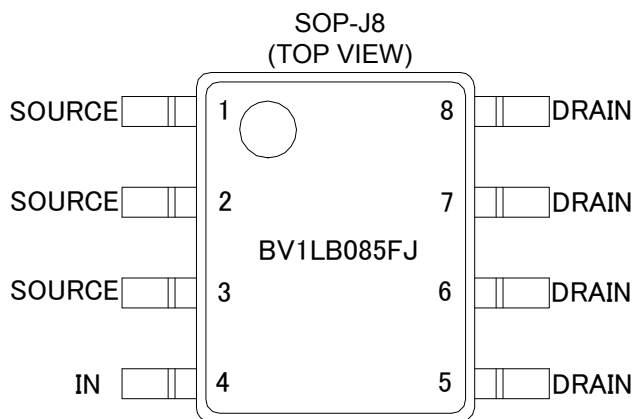

Pin Descriptions

Pin No.	Symbol	Function
1	SOURCE	GND pin
2	SOURCE	GND pin
3	SOURCE	GND pin
4	IN	Input pin (Note 1)
5	DRAIN	Output pin
6	DRAIN	Output pin
7	DRAIN	Output pin
8	DRAIN	Output pin

(Note 1) Input pin is used to internally connect a pull-down resistor.

Definition

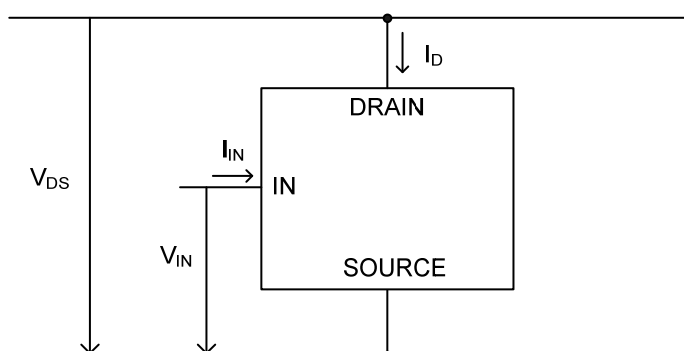

Figure 1. Definition

Absolute Maximum Ratings (T_j = 25°C)

Parameter	Symbol	Ratings	Unit
Drain-Source voltage in output block	V _{DS}	-0.3 to +42 (Note 1)	V
Input voltage	V _{IN}	-0.3 to +7	V
Output current (DC)	I _D	13 (Note 2)	A
Active clamp energy (Single pulse) T _{j(start)} = 25°C (Note 3)	E _{AS(25°C)}	260	mJ
Active clamp energy (Single pulse) T _{j(start)} = 150°C (Note 3) (Note 4)	E _{AS(150°C)}	105	
Operating temperature range	T _j	-40 to +150	°C
Storage temperature range	T _{stg}	-55 to +150	°C
Maximum junction temperature	T _{jmax}	150	°C

(Note 1) Please refer to P.16 "Operation Notes", when is used at less than -0.3V.

(Note 2) Internally limited by the overcurrent limiting circuit.

(Note 3) Maximum Active clamp energy, using single non-repetitive pulse of 1.5A, V_B = 16V.

$$E_{AS} = \frac{1}{2} L I_{AR}^2 \cdot \left(1 - \frac{V_B}{V_B - V_{CL}} \right)$$

(Note 4) Not 100% tested.

Thermal Characteristics (Note 1)

Parameter	Symbol	Ratings	Unit	Conditions
SOP-J8				
Thermal Resistance between channel and ambient temperature	θ_{JA}	143.7	°C / W	1s (Note 2)
		86.9	°C / W	2s (Note 3)
		67.5	°C / W	2s2p (Note 4)

(Note 1) The thermal impedance is based on JESD51 - 2A (Still - Air) standard. It is used the chip of BV1LB085FJ-C.

(Note 2) JESD51 - 3 compliance FR4 114.3 mm × 76.2 mm × 1.57 mm 1 layer (1s)
 (top layer copper : Rohm recommend land pattern + measurement wiring, copper thickness 2oz)

(Note 3) JESD51 -5 compliance FR4 114.3 mm × 76.2 mm × 1.60 mm 2 layer (2s)
 (top layer copper : Rohm recommend land partten + measurement wiring, bottom layer copper area : 74.2 mm × 74.2 mm,
 Copper thickness (top and bottom layer) 2 oz)

(Note 4) JESD51 -5 / -7 compliance FR4 114.3 mm × 76.2 mm × 1.60 mm 4 layer (2s2p)
 (top layer copper : Rohm recommend land pattern + measurement wiring / 2 layer, 3 layer, bottom layer copper area: 74.2 mm × 74.2 mm,
 Copper thickness (top and bottom layer / inner layer) 2 oz / 1oz)

■ PCB layout 1s (1 layer)

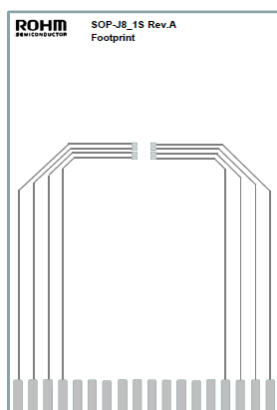

Footprint Only

Figure 2. PCB layout 1s (1 layer)

Dimension	Value
Board finish thickness	1.57 mm ± 10%
Board dimension	76.2 mm x 114.3 mm
Board material	FR4
Copper thickness (Top layer)	0.070mm (Cu:2oz)

■ PCB layout 2s (2layer)

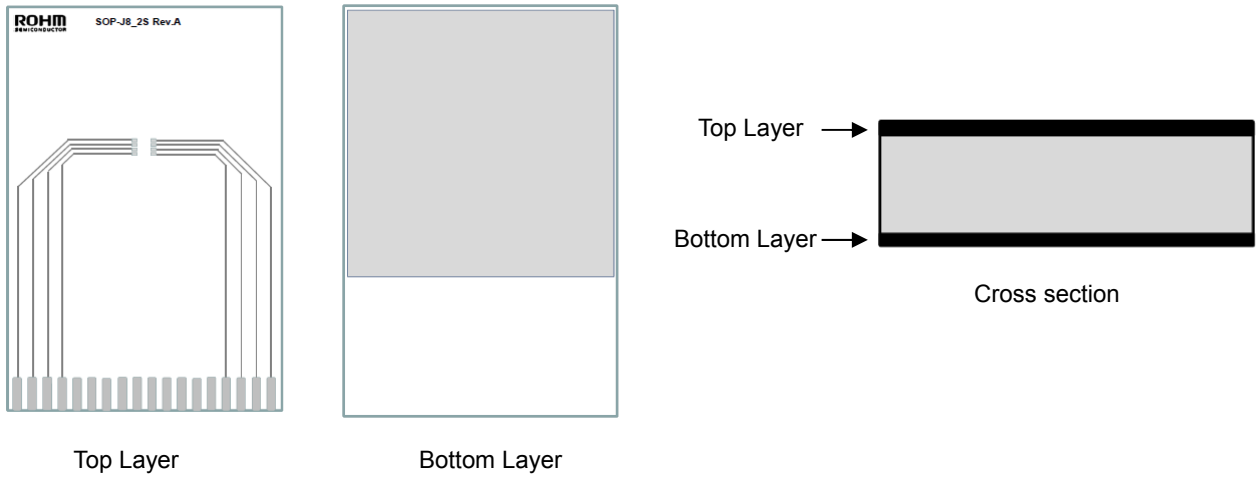

Figure 3. PCB layout 2s(2 layer)

Dimension	Value
Board finish thickness	1.60 mm ± 10%
Board dimension	76.2 mm x 114.3 mm
Board material	FR4
Copper thickness (Top/Bottom layers)	0.070mm (Cu + Plating)

■ PCB layout 2s2p (4layer)

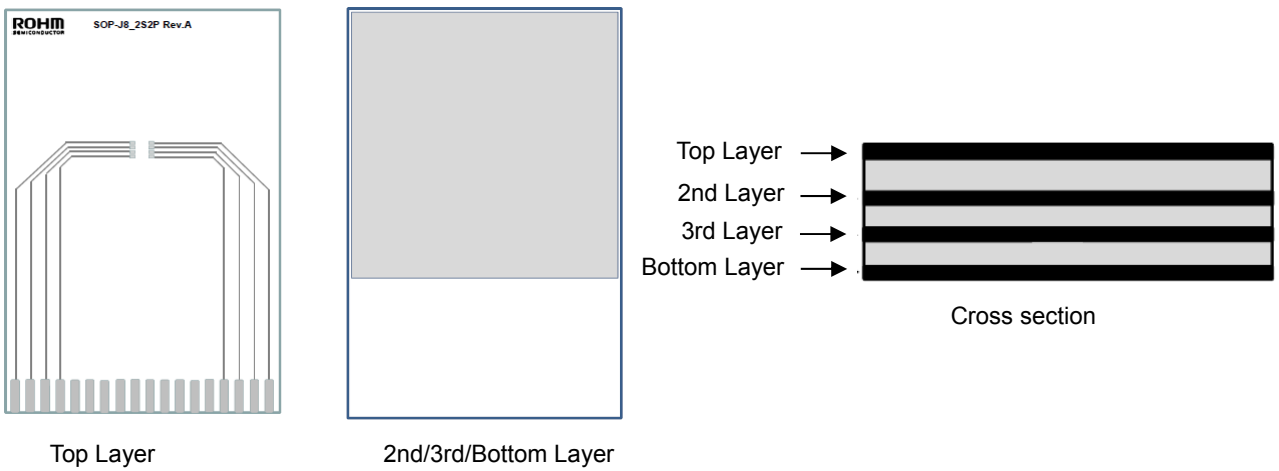

Figure 4. PCB layout 2s2p (4 layer)

Dimension	Value
Board finish thickness	1.60 mm ± 10%
Board dimension	76.2 mm x 114.3 mm
Board material	FR4
Copper thickness (Top/Bottom layers)	0.070mm (Cu + Plating)
Copper thickness (Inner layers)	0.035mm

■ Over Thermal Resistance (Single Pulse)

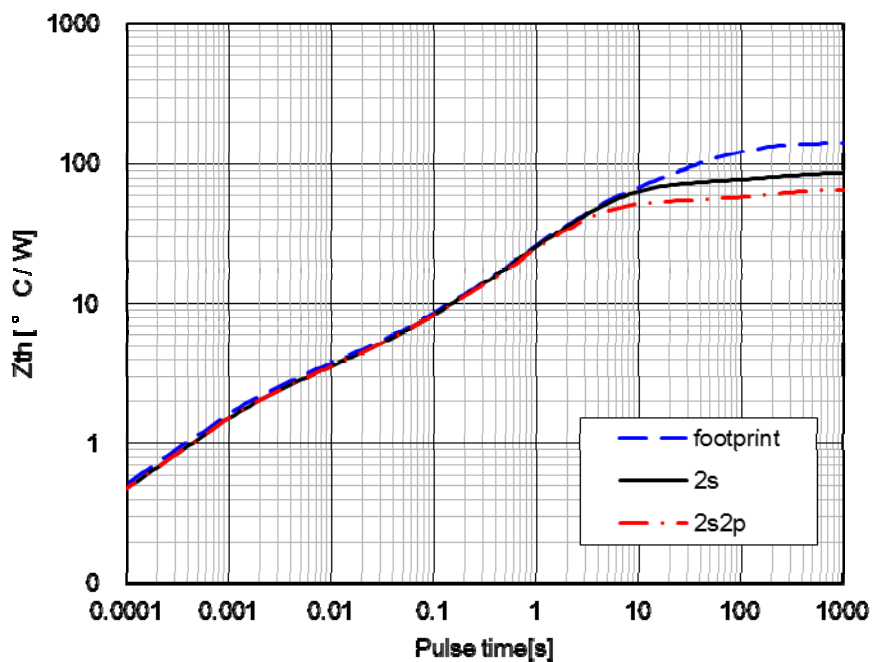

Figure 5. Over Thermal Resistance

Electrical Characteristics (Unless otherwise specified, $-40^{\circ}\text{C} \leq T_j \leq +150^{\circ}\text{C}$ and $V_{\text{IN}}=3.0\text{V}$ to 5.5V)

Parameter	Symbol	Limit			Unit	Conditions
		Min	Typ	Max		
Output Clamp Voltage	V_{CL}	42	48	54	V	$V_{\text{IN}}=0\text{V}$, $I_{\text{D}}=1\text{mA}$
On-state Resistance1 (at 25 °C)	R_{ON1}	-	85	120	m Ω	$V_{\text{IN}}=5\text{V}$, $I_{\text{D}}=0.5\text{A}$, $T_j=25^{\circ}\text{C}$
On-state Resistance1 (at 150 °C)	R_{ON2}	-	155	210	m Ω	$V_{\text{IN}}=5\text{V}$, $I_{\text{D}}=0.5\text{A}$, $T_j=150^{\circ}\text{C}$
On-state Resistance2 (at 25 °C)	R_{ON3}	-	115	150	m Ω	$V_{\text{IN}}=3\text{V}$, $I_{\text{D}}=0.5\text{A}$, $T_j=25^{\circ}\text{C}$
On-state Resistance2 (at 150 °C)	R_{ON4}	-	195	260	m Ω	$V_{\text{IN}}=3\text{V}$, $I_{\text{D}}=0.5\text{A}$, $T_j=150^{\circ}\text{C}$
Leak Current (at 25 °C)	V_{IL1}	-	0	6.5	μA	$V_{\text{IN}}=0\text{V}$, $V_{\text{DS}}=18\text{V}$, $T_j=25^{\circ}\text{C}$
Leak Current (at 150 °C)	V_{IL2}	-	5	40	μA	$V_{\text{IN}}=0\text{V}$, $V_{\text{DS}}=18\text{V}$, $T_j=150^{\circ}\text{C}$
Turn-ON Time	t_{ON}	-	-	100	μs	$V_{\text{IN}}=0\text{V}/5\text{V}$, $R_{\text{L}}=15\Omega$, $V_{\text{B}}=12\text{V}$, $T_j=25^{\circ}\text{C}$
Turn-OFF Time	t_{OFF}	-	-	100	μs	$V_{\text{IN}}=0\text{V}/5\text{V}$, $R_{\text{L}}=15\Omega$, $V_{\text{B}}=12\text{V}$, $T_j=25^{\circ}\text{C}$
Slew Rate ON	SR_{ON}	-	0.5	1.0	V/ μs	$V_{\text{IN}}=0\text{V}/5\text{V}$, $R_{\text{L}}=15\Omega$, $V_{\text{B}}=12\text{V}$, $T_j=25^{\circ}\text{C}$
Slew Rate OFF	SR_{OFF}	-	1.0	2.0	V/ μs	$V_{\text{IN}}=0\text{V}/5\text{V}$, $R_{\text{L}}=15\Omega$, $V_{\text{B}}=12\text{V}$, $T_j=25^{\circ}\text{C}$
Input Threshold Voltage	V_{TH}	1.1	-	2.7	V	$I_{\text{D}}=1\text{mA}$
High-level Input Current1 (in normal operation)	I_{INH1}	-	150	300	μA	$V_{\text{IN}}=5\text{V}$
High-level Input Current2 (in abnormal operation)	I_{INH2}	-	300	500	μA	$V_{\text{IN}}=5\text{V}$
Low-level Input Current	I_{INL}	-10	0	10	μA	$V_{\text{IN}}=0\text{V}$
Overcurrent Detection Current	I_{OCP}	13.0	17.5	22.0	A	$V_{\text{IN}}=5\text{V}$, $T_j=25^{\circ}\text{C}$
TSD Detection Temperature (Note 1)	T_{jd}	150	175	-	$^{\circ}\text{C}$	$V_{\text{IN}}=5\text{V}$
TSD Release Temperature (Note 1)	T_{jr}	130	-	-	$^{\circ}\text{C}$	$V_{\text{IN}}=5\text{V}$
TSD Hysteresis (Note 1)	ΔT_{jd}	-	15	-	$^{\circ}\text{C}$	$V_{\text{IN}}=5\text{V}$

(Note 1) Not 100% tested.

Measuring Circuit

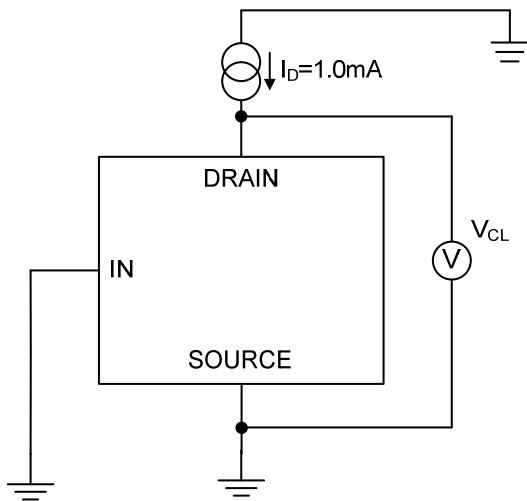

Figure 6. Output Clamp Voltage Measuring Circuit

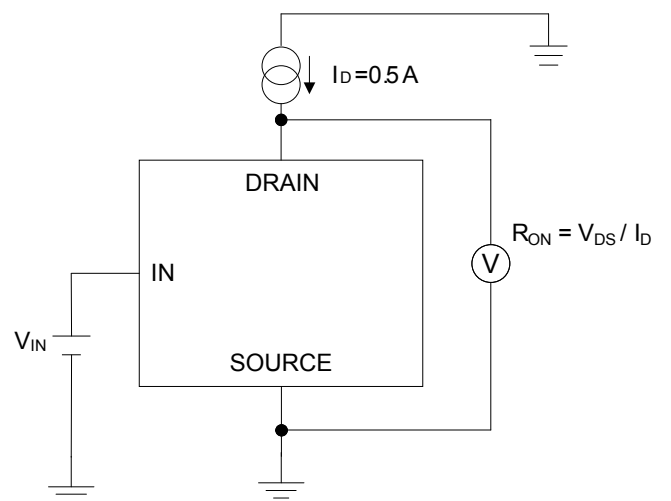

Figure 7. On-state Resistance Measuring Circuit

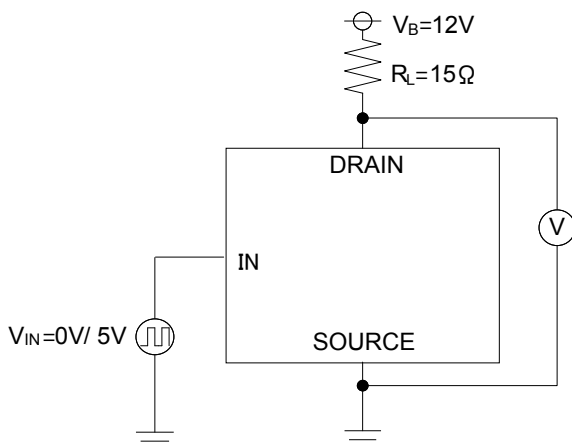

Figure 8. $t_{ON} \cdot t_{OFF}$ Measuring Circuit

I/O Pin Truth Table

Operating Status	Input Signal	Output Level	Output Status
Normal	H	L	ON
	L	H	OFF
Overcurrent	H	H	Current limiting
	L	H	OFF
Overheating	H	H	OFF
	L	H	OFF

Typical Performance Curves (Unless otherwise specified, $T_j=25^\circ\text{C}$, $V_{IN}=5.0\text{V}$)

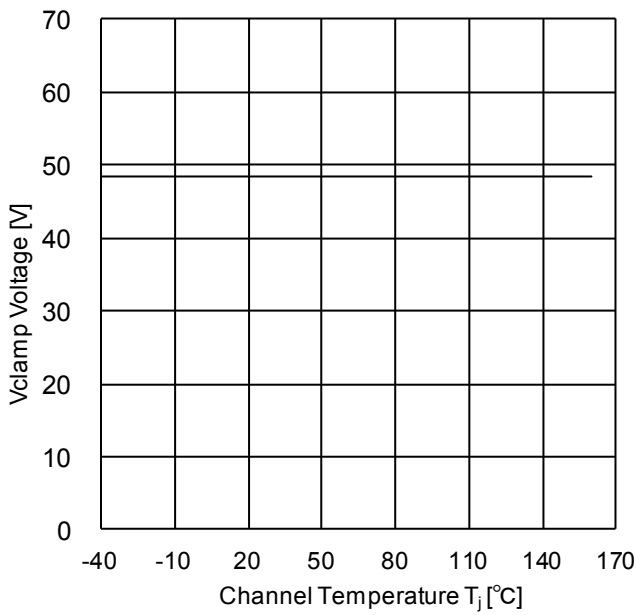

Figure 9. Outout Clamp Voltage vs. Junction Temperature

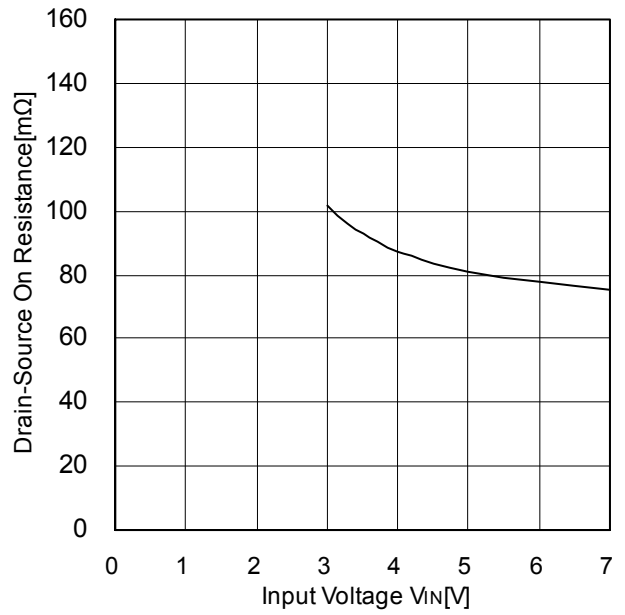

Figure 10. On-state Resistance Characteristics (Input Voltage Characteristics)

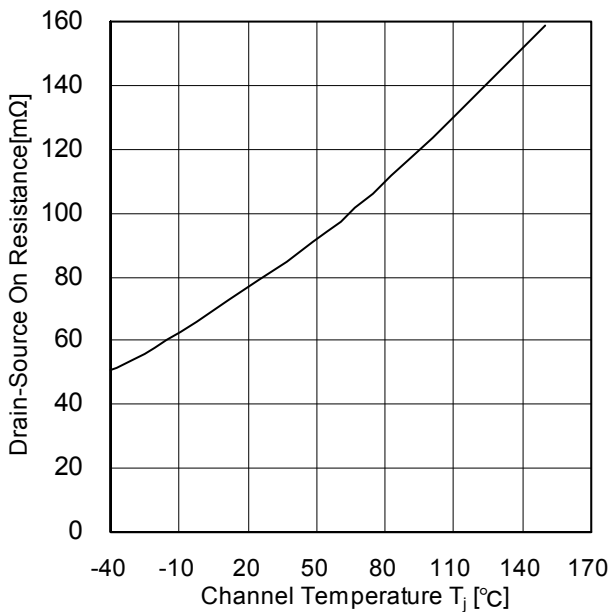

Figure 11. On-state Resistance Characteristics (Temperature Characteristics)

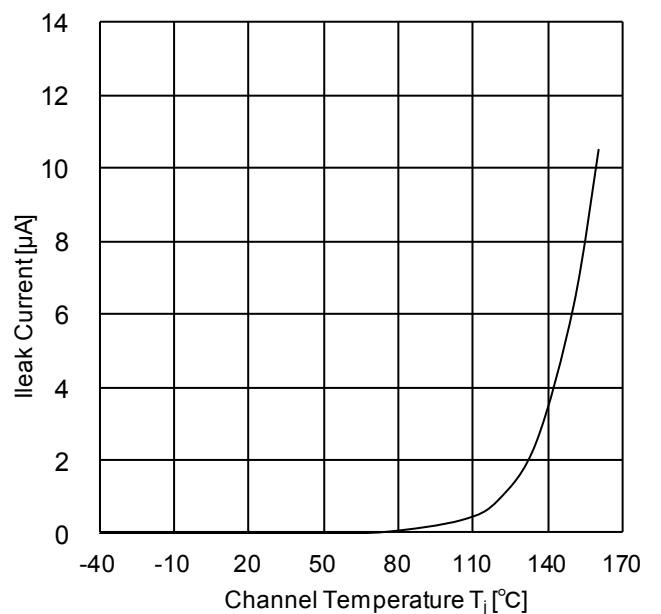

Figure 12. Leak Current vs. Junction Temperature

Typical Performance Curves (Unless otherwise specified, $T_j=25^\circ\text{C}$, $V_{IN}=5.0\text{V}$) - continued

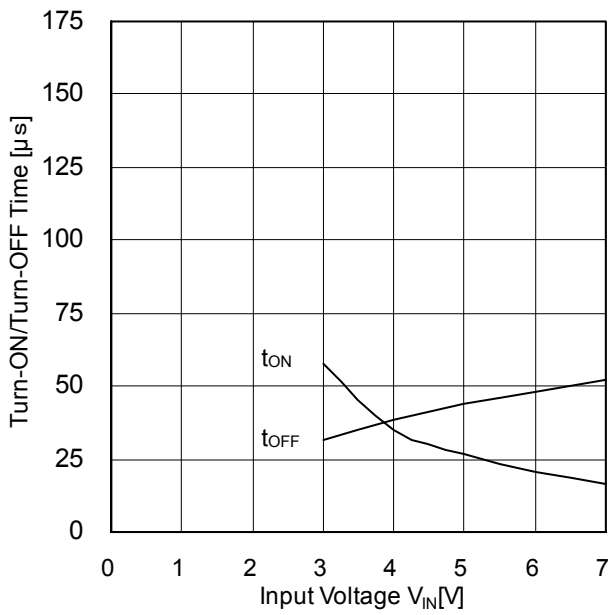

Figure 13. Turn-ON / Turn-OFF Time Characteristics (Input Voltage Characteristics)

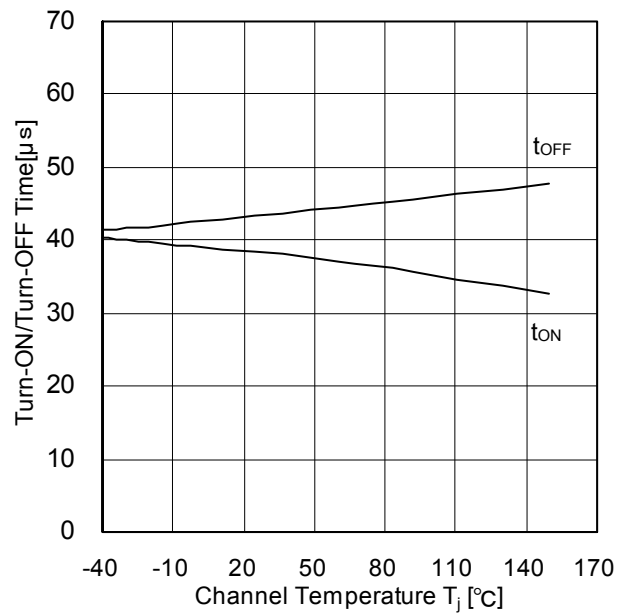

Figure 14. Turn-ON / Turn-OFF Time vs. Junction Temperature

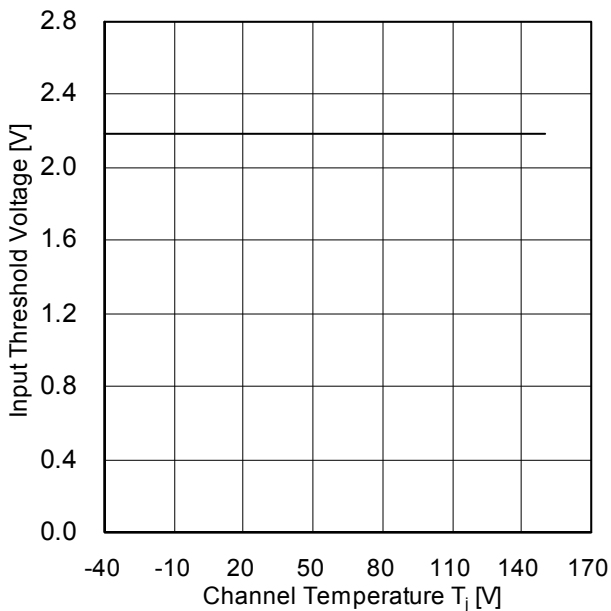

Figure 15. Input Threshold Voltage Characteristics (Temperature Characteristics)

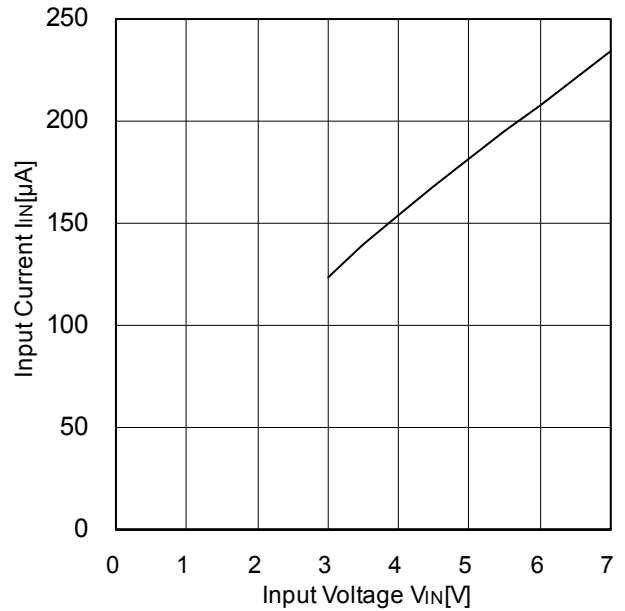

Figure 16. Input Current Characteristics (Input Voltage Characteristics)

Typical Performance Curves (Unless otherwise specified, $T_j=25^\circ\text{C}$, $V_{IN}=5.0\text{V}$) - continued

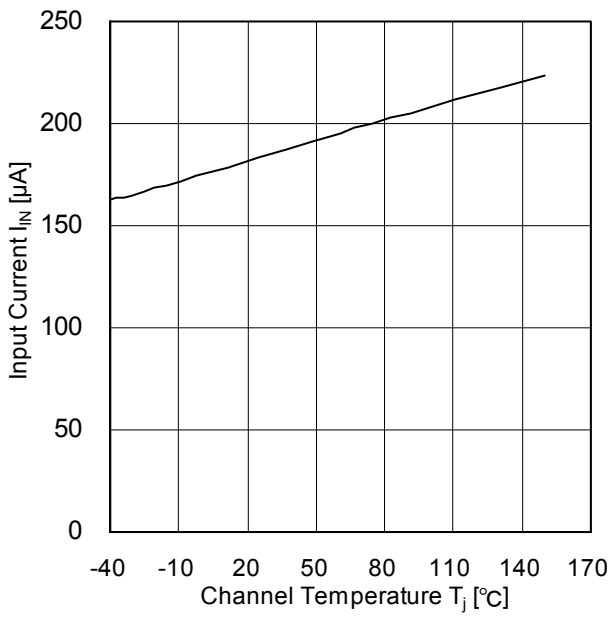

Figure 17. Input Current Characteristics (Temperature Characteristics)

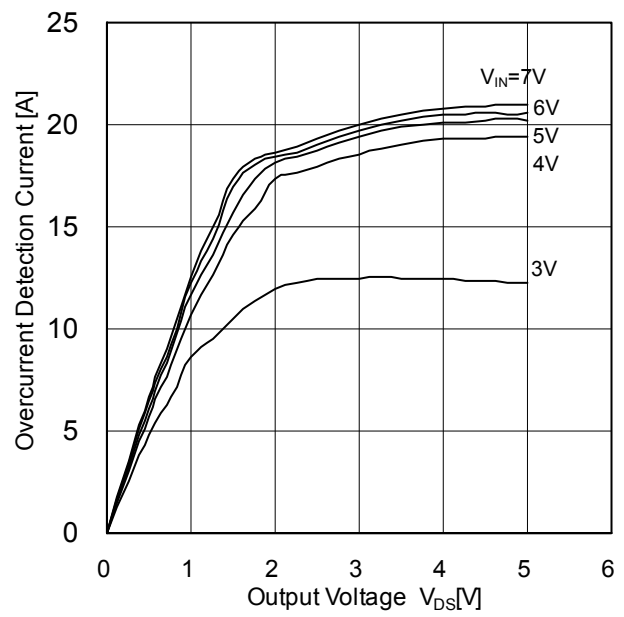

Figure 18. Overcurrent Detection Current Characteristics (Input Voltage Characteristics)

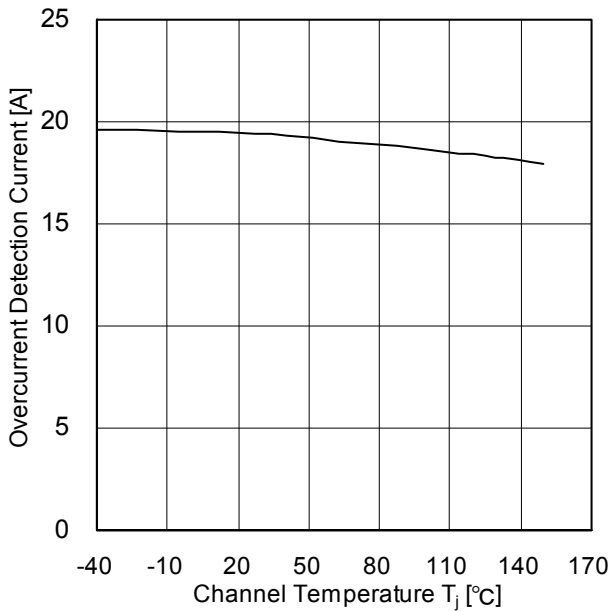

Figure 19. Overcurrent Detection Current Characteristics (Temperature Characteristics)

Timing Chart

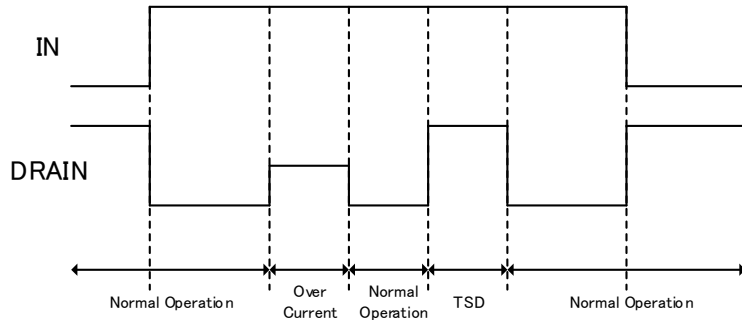

Figure 20. Operation Sequence

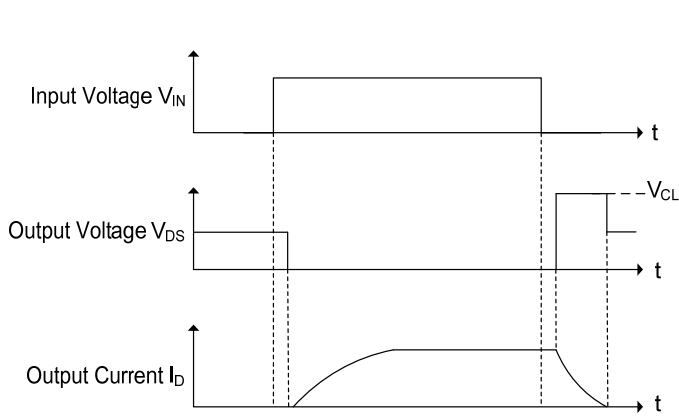

Figure 21. Inductive Load Operation

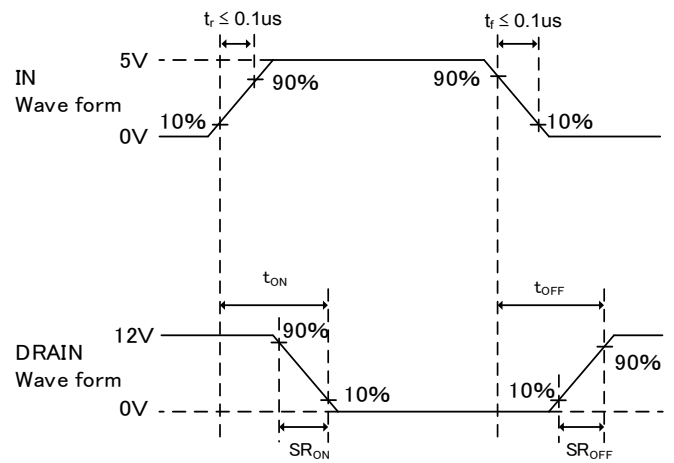

Figure 22. Switching Time

Ordering Information

B V 1 L B 0 8 5 F J

CE2

Package
FJ : SOP-J8

Packaging and forming specification
C : Automotive product
E2 : Embossed tape and reel
(SOP-J8)

Marking Diagram

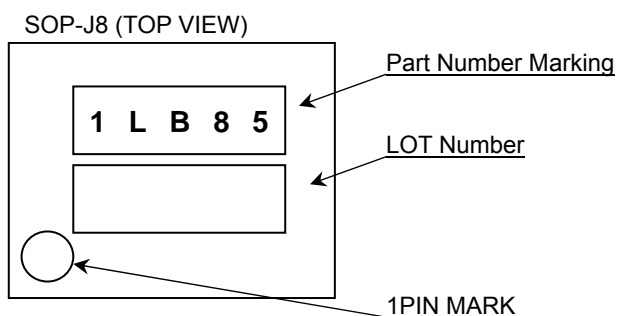

Physical Dimension, Tape and Reel Information

Package Name	SOP-J8
--------------	--------

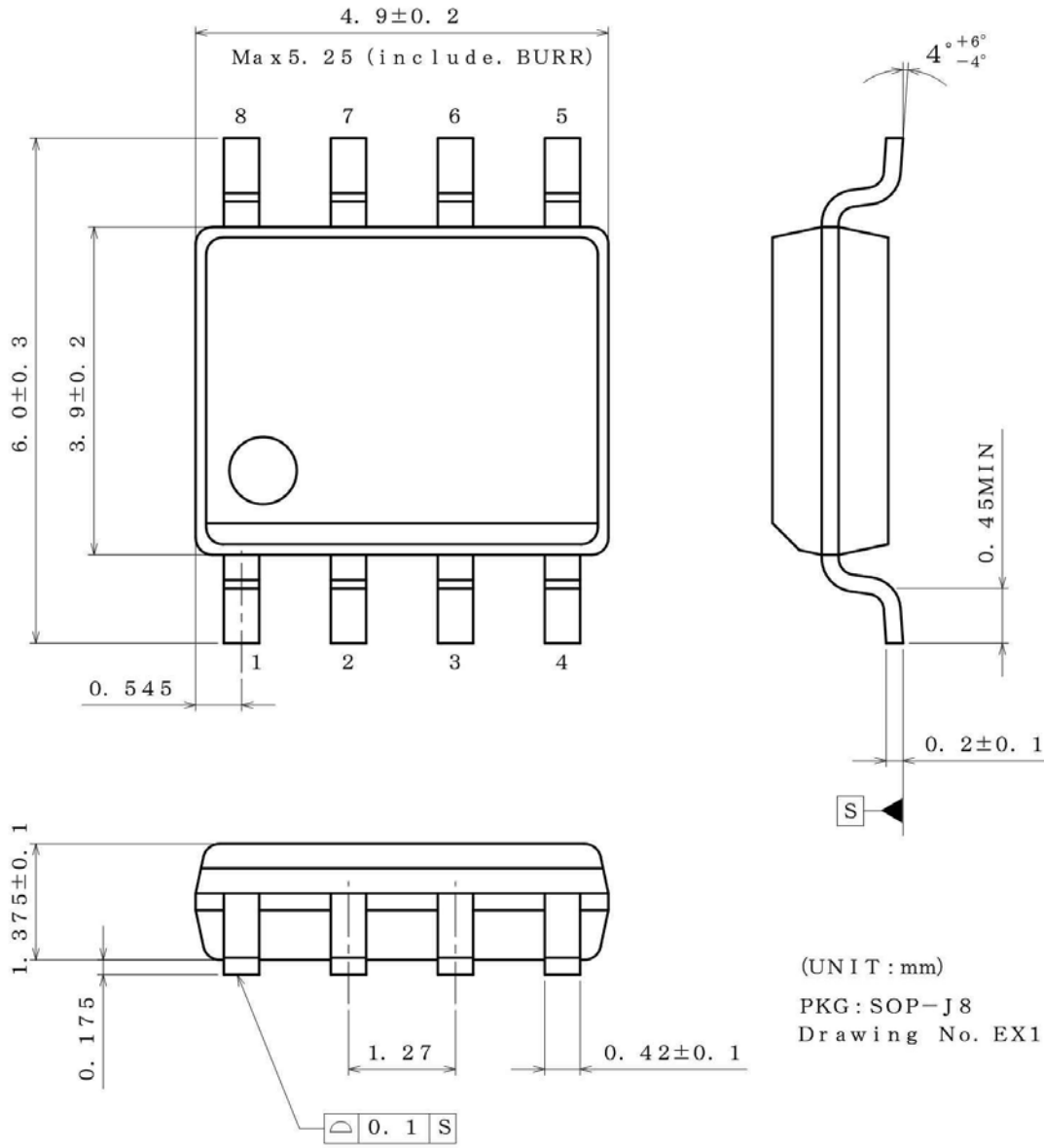

(UNIT : mm)
 PKG : SOP-J8
 Drawing No. EX111-5002

<Tape and Reel information>

Tape	Embossed carrier tape
Quantity	2500pcs
Direction of Feed	E2 (The direction is the 1pin of product is at the upper left when you hold reel on the left hand and pull out the tape on the right hand)

Reel → Direction of Feed →

1pin
 ※Order quantity need to be multiple of minimum quantity.

Operational Notes

1. Grounding Interconnection Pattern

When a small-signal ground and a high-current ground are used, it is recommended to isolate the high-current grounding interconnection pattern and the small-signal grounding interconnection pattern and establish a single ground at the reference point of a set so that voltage changes due to the resistance and high current of patterned interconnects will not cause any changes in the small-signal ground voltage. Pay careful attention to prevent changes in the interconnection pattern of ground for external components.

The ground lines must be as short and thick as possible to reduce line impedance.

2. Thermal Design

Use a thermal design that allows for a sufficient margin by taking into account thermal resistance in actual operating conditions.

3. Absolute Maximum Ratings

Operating the IC over the absolute maximum ratings may damage the IC. The damage can either be a short circuit between pins or an open circuit between pins and the internal circuitry. Therefore, it is important to consider circuit protection measures, such as adding a fuse, in case the IC is operated over the absolute maximum ratings.

4. Inspections on Set Board

If a capacitor is connected to a low-impedance pin in order to conduct inspections of the IC on a set board, stress may apply to the IC. To avoid that, be sure to discharge the capacitor in each process. In addition, to connect or disconnect the IC to or from a jig in the testing process, be sure to turn OFF the power supply prior to connecting the IC, and disconnect it from the jig only after turning OFF the power supply. Furthermore, in order to protect the IC from static electricity, establish a ground for the IC assembly process and pay utmost attention to transport and store the IC.

5. Inter-pin Short and Mounting Errors

Ensure that the direction and position are correct when mounting the IC on the PCB. Incorrect mounting may result in damaging the IC. Avoid nearby pins being shorted to each other especially to ground, power supply and output pin. Inter-pin shorts could be due to many reasons such as metal particles, water droplets (in very humid environment) and unintentional solder bridge deposited in between pins during assembly to name a few.

6. Ceramic Capacitor

When using a ceramic capacitor, determine the dielectric constant considering the change of capacitance with temperature and the decrease in nominal capacitance due to DC bias and others.

7. Thermal Shutdown Circuit

IC has a built-in thermal shutdown circuit as an overheat-protection measure. The circuit is designed to turn OFF output when the temperature of the IC chip exceeds 175°C (Typ) and return the IC to the normal operation when the temperature falls below 160°C (Typ).

The thermal shutdown circuit is a circuit absolutely intended to protect the IC from thermal runaway, not intended to protect or guarantee the IC. Consequently, do not operate the IC based on the subsequent continuous use or operation of the circuit.

8. Overcurrent Limiting Circuit

IC incorporates an integrated overcurrent protection circuit that is activated when the load is shorted. This protection circuit is effective in preventing damage due to sudden and unexpected incidents. However, the IC should not be used in applications characterized by continuous operation or transitioning of the protection circuit.

9. Overvoltage (Active Clamp) Protection Function

IC has a built-in overvoltage protection function in order for the IC to absorb counter-electromotive force energy generated when inductive load is turned OFF. Since the input voltage is clamped at 0V. When the active clamp circuit is activated, the thermal shutdown circuit is disabled. Design a thermal solution so that the chip temperature will definitely come to less than 150°C.

10. Counter-electromotive Force

Fully ensure that the counter-electromotive force presents no problems in the operation or the IC.

11. Reverse Connection of Power Supply

The reverse connection of the power supply connector may cause this IC to break down. In order to avoid the reverse connection breakdown, mount an external diode between the power supply and the power supply pin of the IC, or take other protection measures.

Operational Notes – continued

12. Negative Current of Output

When supply a negative current from DRAIN terminal in the state that supplied the voltage to IN terminal. The current pass from IN terminal to DRAIN terminal through a parasitic transistor and voltage of IN terminal descend as shown in figure.23 and figure.24.

As shown in figure.23 power MOS is turned on, set the DRAIN terminal is more than -0.3V. Because a negative current may be passed to DRAIN terminal from a power supply of the connection of the IN terminal (MCU, and so on).

As shown in figure.24 power MOS is turned off, add a restriction resistance higher than 330 Ω to IN terminal. Because a negative current may be passed to DRAIN terminal of the connection of the IN terminal.

The restriction resistance value, set up in consideration of the voltage descent caused by the IN terminal current.

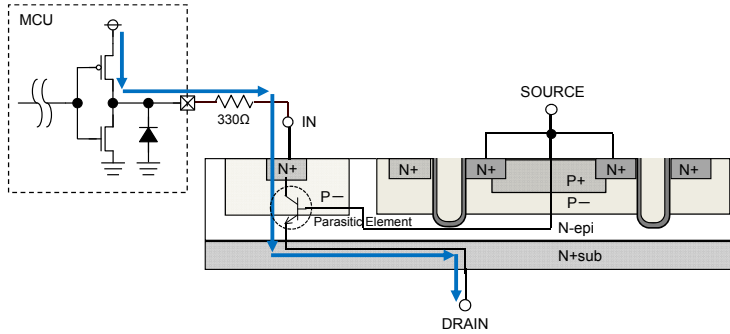

Figure 23. Negative current pass (when power MOS is turned on)

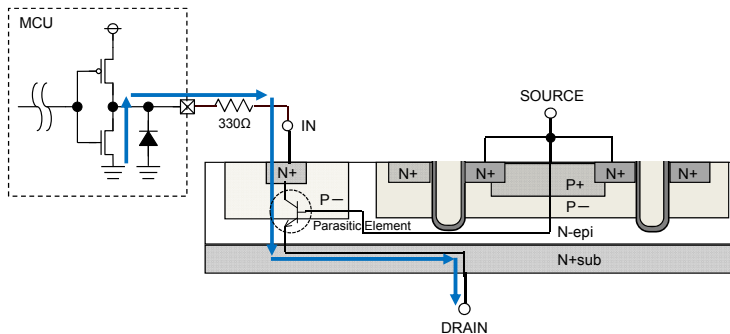

Figure 24. Negative current pass (when power MOS is turned off)

Revision History

Date	Revision	Changes
17.Mar.2016	001	New Release
31.Jan.2017	002	P.4 "Thermal Characteristics" "Top/Bottom layers" modify to "Top layer". P.7 "Electrical Characteristics" "T _j " modify to "T _j " P9-11 "Typical Performance Curves" "T _j " modify to "T _j " "V _{IN} " modify to "V _{IN} " P.15 Revised expression on the information of Thermal Design. P.15 Add "Counter-electromotive Force"

Notice

Precaution on using ROHM Products

1. If you intend to use our Products in devices requiring extremely high reliability (such as medical equipment ^(Note 1), aircraft/spacecraft, nuclear power controllers, etc.) and whose malfunction or failure may cause loss of human life, bodily injury or serious damage to property ("Specific Applications"), please consult with the ROHM sales representative in advance. Unless otherwise agreed in writing by ROHM in advance, ROHM shall not be in any way responsible or liable for any damages, expenses or losses incurred by you or third parties arising from the use of any ROHM's Products for Specific Applications.

(Note1) Medical Equipment Classification of the Specific Applications

JAPAN	USA	EU	CHINA
CLASS III	CLASS III	CLASS II b	CLASS III
CLASS IV		CLASS III	

2. ROHM designs and manufactures its Products subject to strict quality control system. However, semiconductor products can fail or malfunction at a certain rate. Please be sure to implement, at your own responsibilities, adequate safety measures including but not limited to fail-safe design against the physical injury, damage to any property, which a failure or malfunction of our Products may cause. The following are examples of safety measures:
 - [a] Installation of protection circuits or other protective devices to improve system safety
 - [b] Installation of redundant circuits to reduce the impact of single or multiple circuit failure
3. Our Products are not designed under any special or extraordinary environments or conditions, as exemplified below. Accordingly, ROHM shall not be in any way responsible or liable for any damages, expenses or losses arising from the use of any ROHM's Products under any special or extraordinary environments or conditions. If you intend to use our Products under any special or extraordinary environments or conditions (as exemplified below), your independent verification and confirmation of product performance, reliability, etc. prior to use, must be necessary:
 - [a] Use of our Products in any types of liquid, including water, oils, chemicals, and organic solvents
 - [b] Use of our Products outdoors or in places where the Products are exposed to direct sunlight or dust
 - [c] Use of our Products in places where the Products are exposed to sea wind or corrosive gases, including Cl₂, H₂S, NH₃, SO₂, and NO₂
 - [d] Use of our Products in places where the Products are exposed to static electricity or electromagnetic waves
 - [e] Use of our Products in proximity to heat-producing components, plastic cords, or other flammable items
 - [f] Sealing or coating our Products with resin or other coating materials
 - [g] Use of our Products without cleaning residue of flux (even if you use no-clean type fluxes, cleaning residue of flux is recommended); or Washing our Products by using water or water-soluble cleaning agents for cleaning residue after soldering
 - [h] Use of the Products in places subject to dew condensation
4. The Products are not subject to radiation-proof design.
5. Please verify and confirm characteristics of the final or mounted products in using the Products.
6. In particular, if a transient load (a large amount of load applied in a short period of time, such as pulse. is applied, confirmation of performance characteristics after on-board mounting is strongly recommended. Avoid applying power exceeding normal rated power; exceeding the power rating under steady-state loading condition may negatively affect product performance and reliability.
7. De-rate Power Dissipation depending on ambient temperature. When used in sealed area, confirm that it is the use in the range that does not exceed the maximum junction temperature.
8. Confirm that operation temperature is within the specified range described in the product specification.
9. ROHM shall not be in any way responsible or liable for failure induced under deviant condition from what is defined in this document.

Precaution for Mounting / Circuit board design

1. When a highly active halogenous (chlorine, bromine, etc.) flux is used, the residue of flux may negatively affect product performance and reliability.
2. In principle, the reflow soldering method must be used on a surface-mount products, the flow soldering method must be used on a through hole mount products. If the flow soldering method is preferred on a surface-mount products, please consult with the ROHM representative in advance.

For details, please refer to ROHM Mounting specification

Precautions Regarding Application Examples and External Circuits

1. If change is made to the constant of an external circuit, please allow a sufficient margin considering variations of the characteristics of the Products and external components, including transient characteristics, as well as static characteristics.
2. You agree that application notes, reference designs, and associated data and information contained in this document are presented only as guidance for Products use. Therefore, in case you use such information, you are solely responsible for it and you must exercise your own independent verification and judgment in the use of such information contained in this document. ROHM shall not be in any way responsible or liable for any damages, expenses or losses incurred by you or third parties arising from the use of such information.

Precaution for Electrostatic

This Product is electrostatic sensitive product, which may be damaged due to electrostatic discharge. Please take proper caution in your manufacturing process and storage so that voltage exceeding the Products maximum rating will not be applied to Products. Please take special care under dry condition (e.g. Grounding of human body / equipment / solder iron, isolation from charged objects, setting of Ionizer, friction prevention and temperature / humidity control).

Precaution for Storage / Transportation

1. Product performance and soldered connections may deteriorate if the Products are stored in the places where:
 - [a] the Products are exposed to sea winds or corrosive gases, including Cl₂, H₂S, NH₃, SO₂, and NO₂
 - [b] the temperature or humidity exceeds those recommended by ROHM
 - [c] the Products are exposed to direct sunshine or condensation
 - [d] the Products are exposed to high Electrostatic
2. Even under ROHM recommended storage condition, solderability of products out of recommended storage time period may be degraded. It is strongly recommended to confirm solderability before using Products of which storage time is exceeding the recommended storage time period.
3. Store / transport cartons in the correct direction, which is indicated on a carton with a symbol. Otherwise bent leads may occur due to excessive stress applied when dropping of a carton.
4. Use Products within the specified time after opening a humidity barrier bag. Baking is required before using Products of which storage time is exceeding the recommended storage time period.

Precaution for Product Label

A two-dimensional barcode printed on ROHM Products label is for ROHM's internal use only.

Precaution for Disposition

When disposing Products please dispose them properly using an authorized industry waste company.

Precaution for Foreign Exchange and Foreign Trade act

Since concerned goods might be fallen under listed items of export control prescribed by Foreign exchange and Foreign trade act, please consult with ROHM in case of export.

Precaution Regarding Intellectual Property Rights

1. All information and data including but not limited to application example contained in this document is for reference only. ROHM does not warrant that foregoing information or data will not infringe any intellectual property rights or any other rights of any third party regarding such information or data.
2. ROHM shall not have any obligations where the claims, actions or demands arising from the combination of the Products with other articles such as components, circuits, systems or external equipment (including software).
3. No license, expressly or implied, is granted hereby under any intellectual property rights or other rights of ROHM or any third parties with respect to the Products or the information contained in this document. Provided, however, that ROHM will not assert its intellectual property rights or other rights against you or your customers to the extent necessary to manufacture or sell products containing the Products, subject to the terms and conditions herein.

Other Precaution

1. This document may not be reprinted or reproduced, in whole or in part, without prior written consent of ROHM.
2. The Products may not be disassembled, converted, modified, reproduced or otherwise changed without prior written consent of ROHM.
3. In no event shall you use in any way whatsoever the Products and the related technical information contained in the Products or this document for any military purposes, including but not limited to, the development of mass-destruction weapons.
4. The proper names of companies or products described in this document are trademarks or registered trademarks of ROHM, its affiliated companies or third parties.

General Precaution

1. Before you use our Products, you are requested to carefully read this document and fully understand its contents. ROHM shall not be in any way responsible or liable for failure, malfunction or accident arising from the use of any ROHM's Products against warning, caution or note contained in this document.
2. All information contained in this document is current as of the issuing date and subject to change without any prior notice. Before purchasing or using ROHM's Products, please confirm the latest information with a ROHM sales representative.
3. The information contained in this document is provided on an "as is" basis and ROHM does not warrant that all information contained in this document is accurate and/or error-free. ROHM shall not be in any way responsible or liable for any damages, expenses or losses incurred by you or third parties resulting from inaccuracy or errors of or concerning such information.