

Serial-in Parallel-out LED Driver

12 ch LED Driver IC for Automotive with 3-line Serial Interface

BD83812EFV-M

General Description

The BD83812EFV-M is a serial-in parallel-out controlled LED driver.
With the input of 3-line serial data, it turns the 12 ch open drain output on/off.
Due to its compact size, it is optimal for small space.

Features

- AEC-Q100 Qualified^(Note 1)
- Open Drain Output
- 3-line Serial Control + Enable Signal
- Cascade Connection Compatible
- HTSSOP-B20 Package
- Internal 12 ch Power Transistor
- Output Slew Rate 20 V/μs (Typ)
(for Low EMC Noise)
(Note 1) Grade 1

Key Specifications

- Input Voltage Range: 3.0 V to 5.5 V
- Output Voltage Range: 35 V (Max)
- DC Output Current 1 (VBAT < 25 V) : 50 mA (Max)
- DC Output Current 2 (25 V ≤ VBAT ≤ 35 V) : 30 mA (Max)
- Output ON Resistance 1: 6 Ω (Typ)
- Static Current: 0 μA (Typ)
- Operating Temperature Range: -40 °C to +125 °C

Package

HTSSOP-B20

W (Typ) x D (Typ) x H (Max)

6.5 mm x 6.4 mm x 1.0 mm

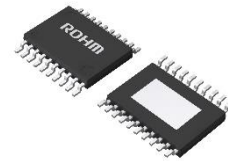

Application

- For Indicator of Cluster Panel

Typical Application Circuit

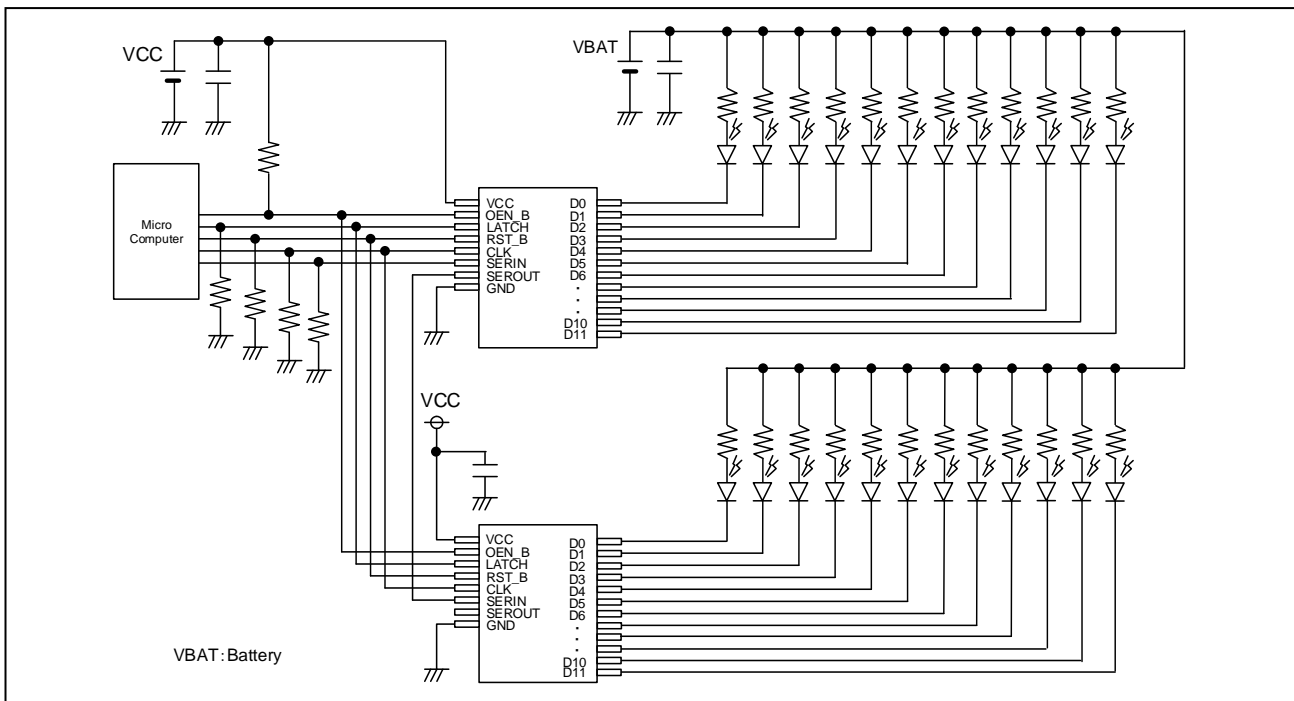

○Product structure : Silicon integrated circuit ○This product has no designed protection against radioactive rays.

Pin Configuration

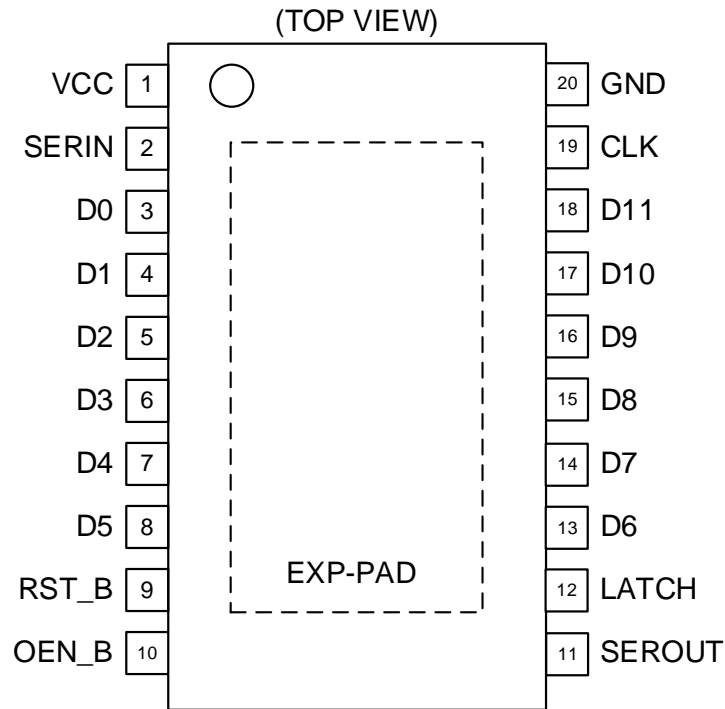

Pin Descriptions

Pin No.	Pin Name	Function
1	VCC	Power supply voltage input pin
2	SERIN	Serial data input pin
3	D0	Drain output pin 0
4	D1	Drain output pin 1
5	D2	Drain output pin 2
6	D3	Drain output pin 3
7	D4	Drain output pin 4
8	D5	Drain output pin 5
9	RST_B	Reset invert input pin (Low: Shift register data 0)
10	OEN_B	Output enable input pin (High: Output OFF)
11	SEROUT	Serial data output pin
12	LATCH	Latch signal input pin (High: Data latch)
13	D6	Drain output pin 6
14	D7	Drain output pin 7
15	D8	Drain output pin 8
16	D9	Drain output pin 9
17	D10	Drain output pin 10
18	D11	Drain output pin 11
19	CLK	Clock input pin
20	GND	GND pin
-	EXP-PAD	The EXP-PAD is connected to GND.

Block Diagram

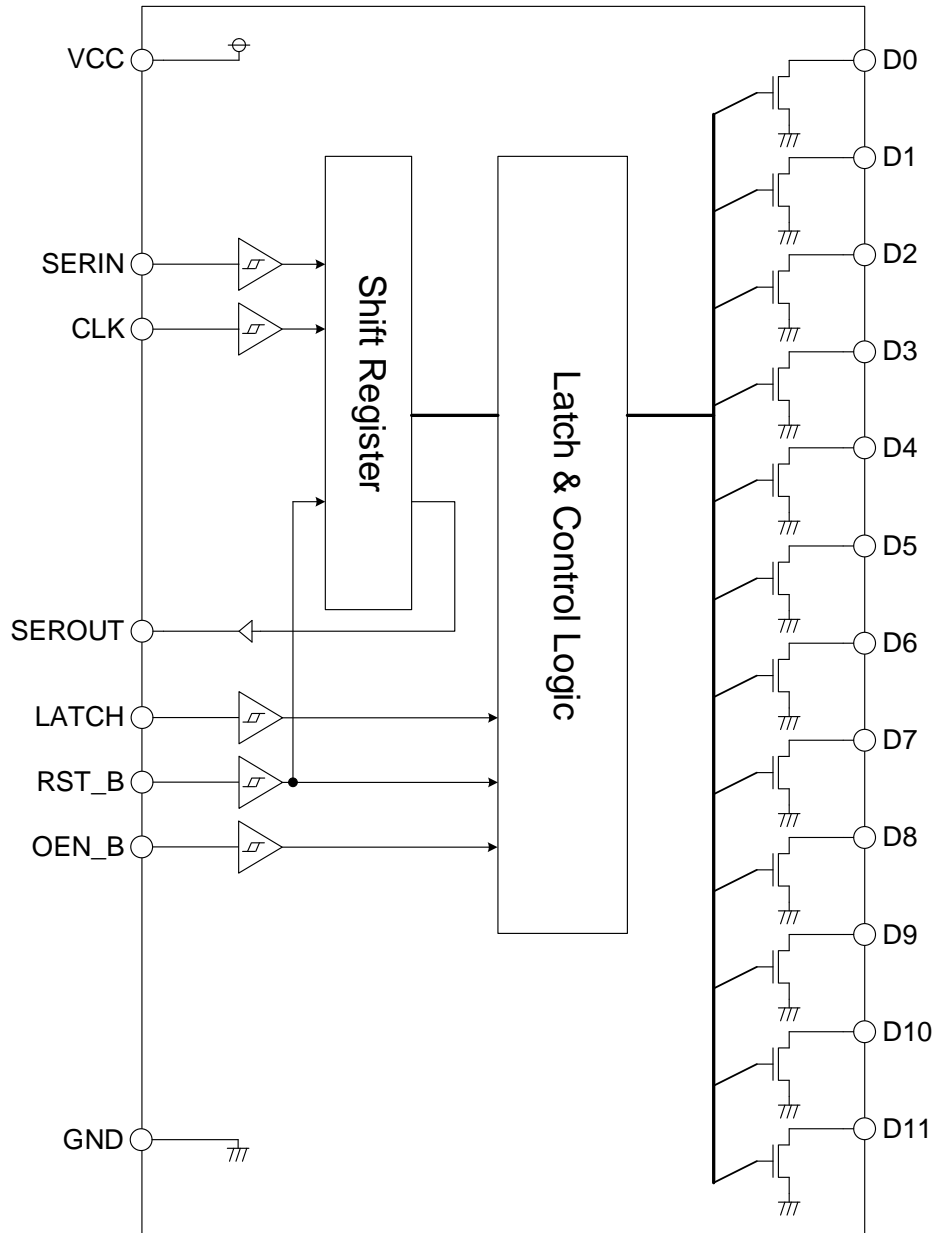

Description of Functions

If there is no description, please refer as typical value.

1 Serial Communication

The serial I/F is composed of a shift register which changes the CLK and SERIN serial signals to parallel signals, and a register to store those signals with a LATCH signal. The registers are reset by applying a voltage V_{TL} or below to the RST_B pin, and D11 to D0 become open. To prevent erroneous LED lighting, apply voltage V_{TL} or below to the RST_B pin during start-up.

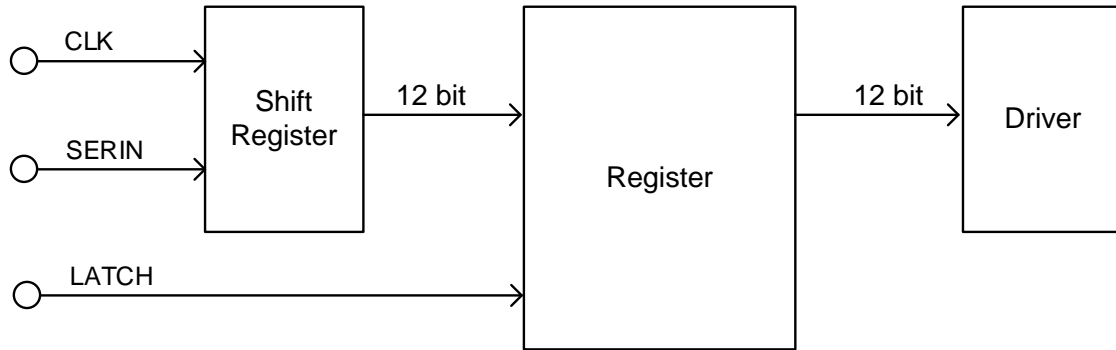

Figure 1. Block Diagram of Serial Communication

1.1 Serial Communication Timing

The 12 bit serial data input from the SERIN pin is taken into the shift register by the rising edge of the signal input to the CLK pin, and is recorded in the register by the rising edge of the signal input to the LATCH pin. The recorded data is valid until the rising edge of the next input LATCH signal.

1.2 Serial Communication Data

The configuration of the serial data input to the SERIN pin is shown below:

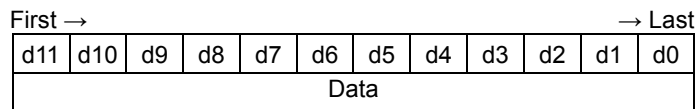

Pin	Output Condition	Data											
		d11	d10	d9	d8	d7	d6	d5	d4	d3	d2	d1	d0
D11	ON	1	*	*	*	*	*	*	*	*	*	*	*
	OFF	0	*	*	*	*	*	*	*	*	*	*	*
D10	ON	*	1	*	*	*	*	*	*	*	*	*	*
	OFF	*	0	*	*	*	*	*	*	*	*	*	*
D9	ON	*	*	1	*	*	*	*	*	*	*	*	*
	OFF	*	*	0	*	*	*	*	*	*	*	*	*
D8	ON	*	*	*	1	*	*	*	*	*	*	*	*
	OFF	*	*	*	0	*	*	*	*	*	*	*	*
...
D3	ON	*	*	*	*	*	*	*	*	1	*	*	*
	OFF	*	*	*	*	*	*	*	*	0	*	*	*
D2	ON	*	*	*	*	*	*	*	*	*	1	*	*
	OFF	*	*	*	*	*	*	*	*	*	0	*	*
D1	ON	*	*	*	*	*	*	*	*	*	*	1	*
	OFF	*	*	*	*	*	*	*	*	*	*	0	*
D0	ON	*	*	*	*	*	*	*	*	*	*	*	1
	OFF	*	*	*	*	*	*	*	*	*	*	*	0

* Indicate Don't care.

1 Serial Communication - continued

1.3 Enable Signal

By applying voltage V_{TH} or more to the OEN_B pin, D11 to D0 become open forcibly. Also, by the PWM input to the OEN_B pin, all outputs can be PWM output at the same time.

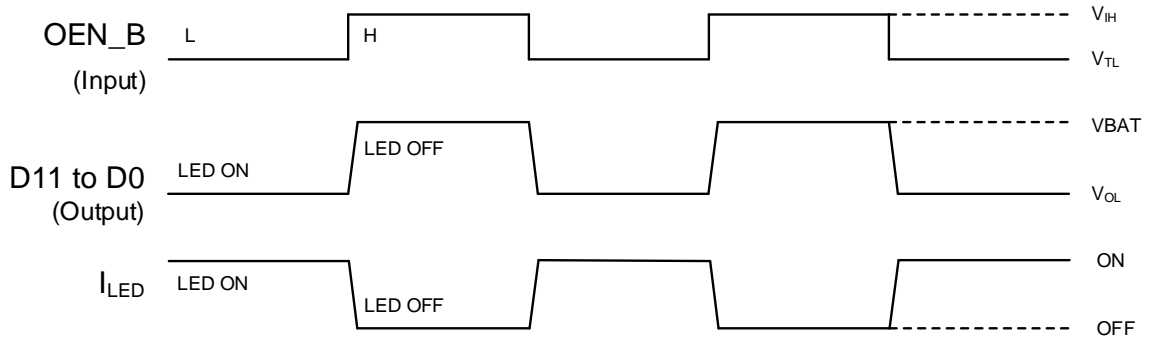

Figure 2. PWM Dimming Control

1.4 SEROUT

A cascade connection can be made (connecting at least 2 or more IC's in serial). Serial signal input from the SERIN pin is transferred into the receiver IC by the falling edge of the CLK signal. Therefore, the setup time for the rising edge of the CLK signal of the receiver IC increases, and the reliability of the cascade connection function increases when using the same CLK signal as the sender IC.

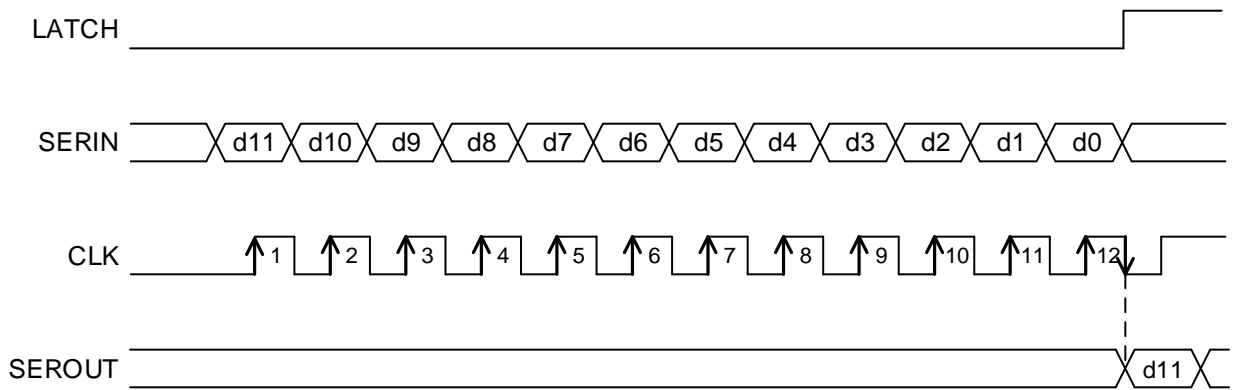

Figure 3. SEROUT Output Signal

2 Cascade Connection

As an application, BD83812EFV-M can turn on 13 or more LED lights. By making a cascade connection between 2 ICs, the LED application of up to 24 lights can be constructed. In this case, the SEROUT pin of the sender IC is connected the SERIN pin of the receiver IC. When sending 24 bit signal to the sender IC, the input serial data is sent to the receiver IC from the SEROUT pin of the sender IC. In addition, it is possible to construct 3 or more applications.

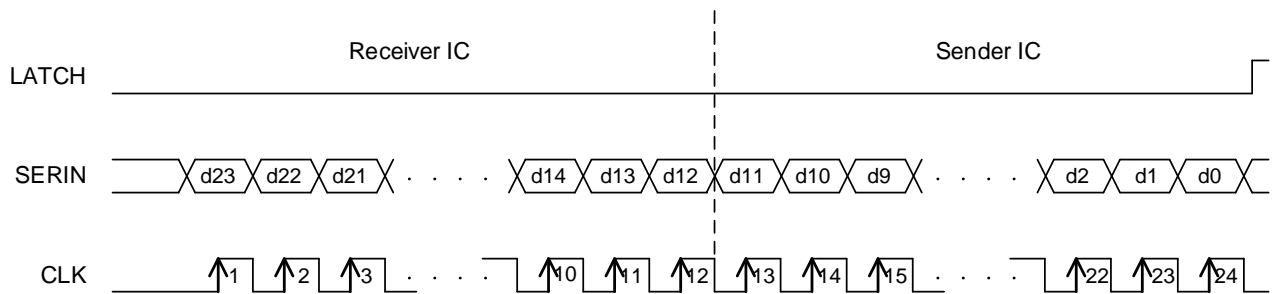

Figure 4. Cascade Connection

Absolute Maximum Ratings(Ta = 25 °C)

Parameter	Symbol	Rating	Unit
Power Supply Voltage	V _{CC}	-0.3 to +7	V
Output Pin Voltage (D0, D1, D2, D3, D4, D5, D6, D7, D8, D9, D10, D11)	V _{D0} , V _{D1} , V _{D2} , V _{D3} , V _{D4} , V _{D5} , V _{D6} , V _{D7} , V _{D8} , V _{D9} , V _{D10} , V _{D11}	-0.3 to +40	V
Pin Voltage (SERIN, RST_B, CLK, OEN_B, LATCH)	V _{SERIN} , V _{RST_B} , V _{CLK} , V _{OEN_B} , V _{LATCH}	-0.3 to +V _{CC}	V
SEROUT Pin Voltage	V _{SEROUT}	-0.3 to +V _{CC}	V
Storage Temperature Range	T _{stg}	-55 to +150	°C
DC Output Maximum Current 1 (VBAT < 25 V)	I _{OMAX1DC}	50	mA
DC Output Maximum Current 2 (25 V ≤ VBAT ≤ 35 V)	I _{OMAX2DC}	30	mA
Maximum Junction Temperature	T _{jmax}	150	°C

Caution 1: Operating the IC over the absolute maximum ratings may damage the IC. The damage can either be a short circuit between pins or an open circuit between pins and the internal circuitry. Therefore, it is important to consider circuit protection measures, such as adding a fuse, in case the IC is operated over the absolute maximum ratings.

Caution 2: Should by any chance the maximum junction temperature rating be exceeded the rise in temperature of the chip may result in deterioration of the properties of the chip. In case of exceeding this absolute maximum rating, design a PCB with thermal resistance taken into consideration by increasing board size and copper area so as not to exceed the maximum junction temperature rating.

Thermal Resistance(Note 1)

Parameter	Symbol	Thermal Resistance (Typ)		Unit
		1s ^(Note 3)	2s2p ^(Note 4)	
HTSSOP-B20				
Junction to Ambient	θ _{JA}	105.8	33.0	°C/W
Junction to Top Characterization Parameter ^(Note 2)	Ψ _{JT}	19	5	°C/W

(Note 1) Based on JESD51-2A (Still-Air). The BD83812EFV-M chip is used.

(Note 2) The thermal characterization parameter to report the difference between junction temperature and the temperature at the top center of the outside surface of the component package.

(Note 3) Using a PCB board based on JESD51-3.

(Note 4) Using a PCB board based on JESD51-5, 7.

Layer Number of Measurement Board	Material	Board Size
Single	FR-4	114.3 mm x 76.2 mm x 1.57 mmt

Top	
Copper Pattern	Thickness
Footprints and Traces	70 μm

Layer Number of Measurement Board	Material	Board Size	Thermal Via ^(Note 5)	
			Pitch	Diameter
4 Layers	FR-4	114.3 mm x 76.2 mm x 1.6 mmt	1.20 mm	Φ0.30 mm

Top		2 Internal Layers		Bottom	
Copper Pattern	Thickness	Copper Pattern	Thickness	Copper Pattern	Thickness
Footprints and Traces	70 μm	74.2 mm x 74.2 mm	35 μm	74.2 mm x 74.2 mm	70 μm

(Note 5) This thermal via connect with the copper pattern of layers 1,2, and 4. The placement and dimensions obey a land pattern.

Recommended Operating Conditions

Parameter	Symbol	Min	Typ	Max	Unit
Power Supply Voltage	V _{CC}	3.0	-	5.5	V
Output Pin Voltage	V _{DN}	-	-	35	V
DC Output Current 1 (V _{BAT} < 25 V)	I _{O1DC}	-	-	50	mA
DC Output Current 2 (25 V ≤ V _{BAT} ≤ 35 V)	I _{O2DC}	-	-	30	mA
Operating Temperature	Topr	-40	-	+125	°C

Electrical Characteristics(Unless otherwise specified V_{CC} = 3.0 V to 5.5 V, Ta = -40 °C to +125 °C)

Parameter	Symbol	Limit			Unit	Condition
		Min	Typ	Max		
Output D0 to D11						
ON Resistance 1 ^(Note 1)	R _{ON1}	-	6	12	Ω	I _{DN} = 20 mA, V _{CC} = 4.5 V to 5.5 V
ON Resistance 2 ^(Note 1)	R _{ON2}	-	9	18	Ω	I _{DN} = 20 mA, V _{CC} = 3.0 V to 4.5 V
Output Leakage Current ^(Note 2)	I _{DL}	-	-	0.3	μA	V _{DN} = 35 V
Logic Input						
Upper Limit Threshold Voltage	V _{TH}	V _{CC} x 0.7	-	-	V	
Bottom Limit Threshold Voltage	V _{TL}	-	-	V _{CC} x 0.2	V	
Serial Clock Frequency	f _{CLK}	-	-	1.25	MHz	
Input Leakage Current Low	I _{INLL}	-5	0	-	μA	V _{TL} = 0 V
Input Leakage Current High	I _{INLH}	-	0	5	μA	V _{TH} = 5 V
Whole						
Circuit Current	I _{CC}	-	0.05	1.00	mA	Serial Data Input, V _{CC} = 5 V, f _{CLK} = 500 kHz, V _{TH} = V _{CC} , V _{TL} = 0 V, SEROUT = OPEN
Static Current	I _{STN}	-	0	50	μA	SEROUT = OPEN
SEROUT						
Output Voltage High 1 ^(Note 3)	V _{OH1}	4.6	4.8	-	V	V _{CC} = 5 V, I _{SO} = -4 mA
Output Voltage Low 1 ^(Note 3)	V _{OL1}	-	0.2	0.4	V	V _{CC} = 5 V, I _{SO} = 4 mA
Output Voltage High 2 ^(Note 3)	V _{OH2}	2.7	3.0	-	V	V _{CC} = 3.3 V, I _{SO} = -4 mA
Output Voltage Low 2 ^(Note 3)	V _{OL2}	-	0.3	0.6	V	V _{CC} = 3.3 V, I _{SO} = 4 mA

(Note 1) I_{DN}: Current flowing to the output DN pin. (N: 0 to 11)

(Note 2) V_{DN}: Output DN pin voltage. (N: 0 to 11)

(Note 3) I_{SO}: Current flowing to the SEROUT pin.

Typical Performance Curves

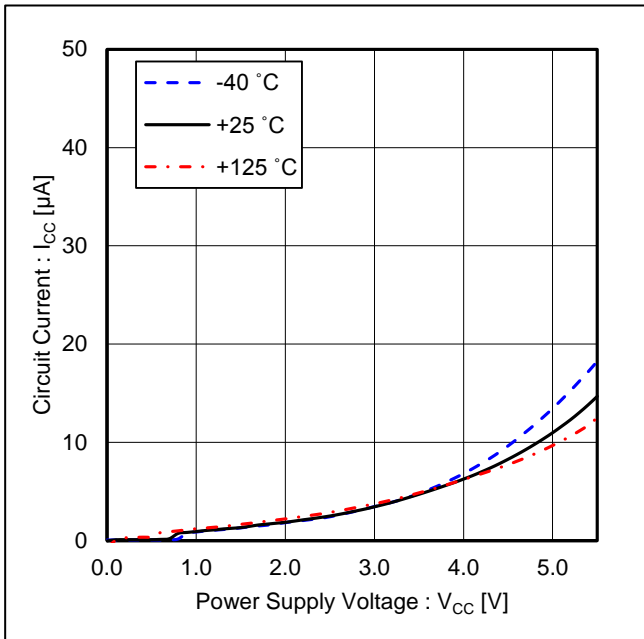

Figure 5. Circuit Current vs Power Supply Voltage (Serial Data Input condition)

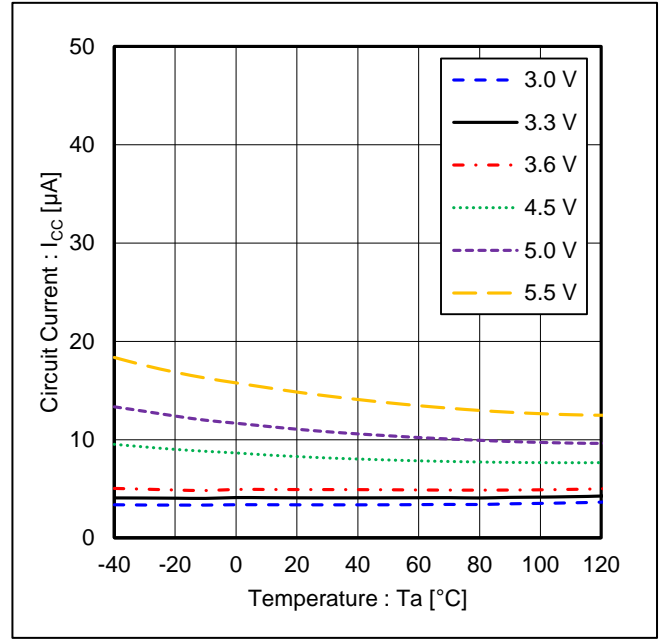

Figure 6. Circuit Current vs Temperature (Serial Data Input condition)

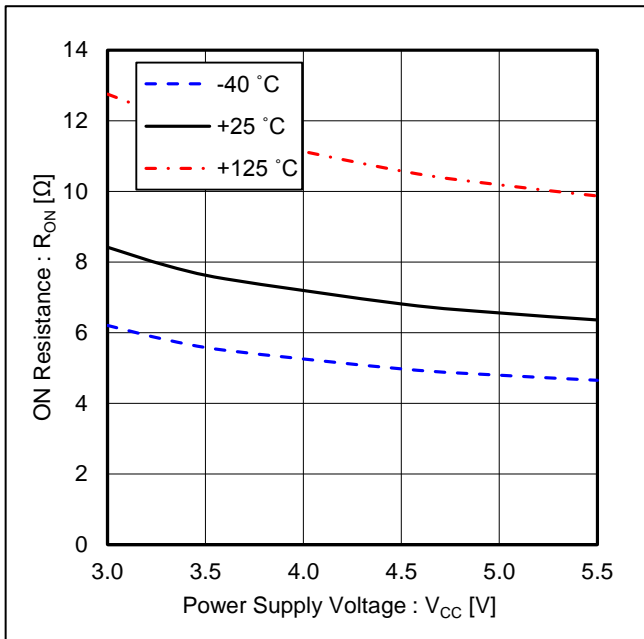

Figure 7. ON Resistance vs Power Supply Voltage (@ $I_{DN} = 20 \text{ mA}$)

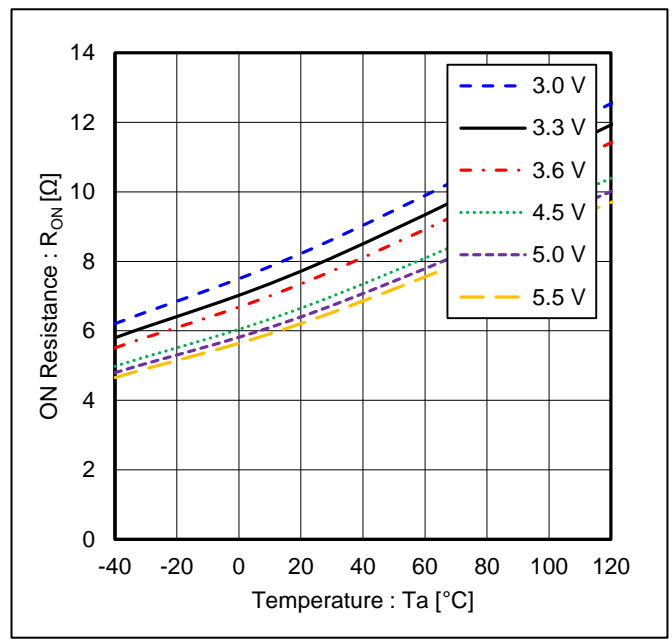

Figure 8. ON Resistance vs Temperature (@ $I_{DN} = 20 \text{ mA}$)

Typical Performance Curves - continued

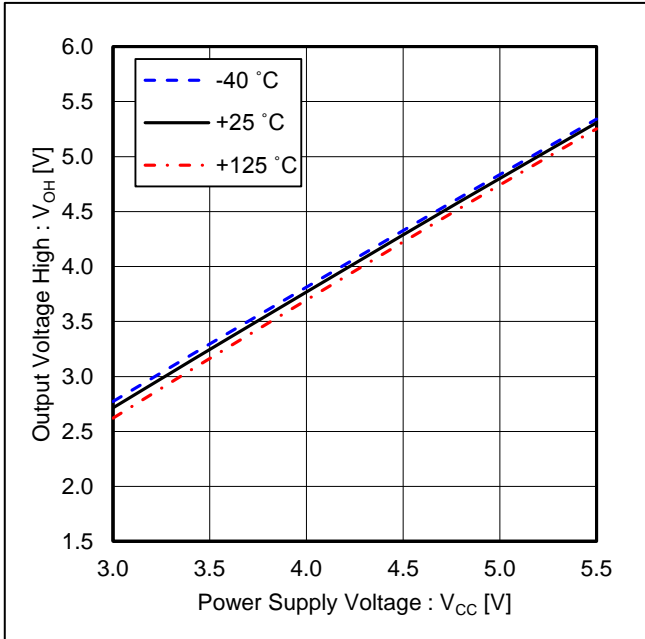

Figure 9. Output Voltage High vs Power Supply Voltage (@I_{so} = -4 mA)

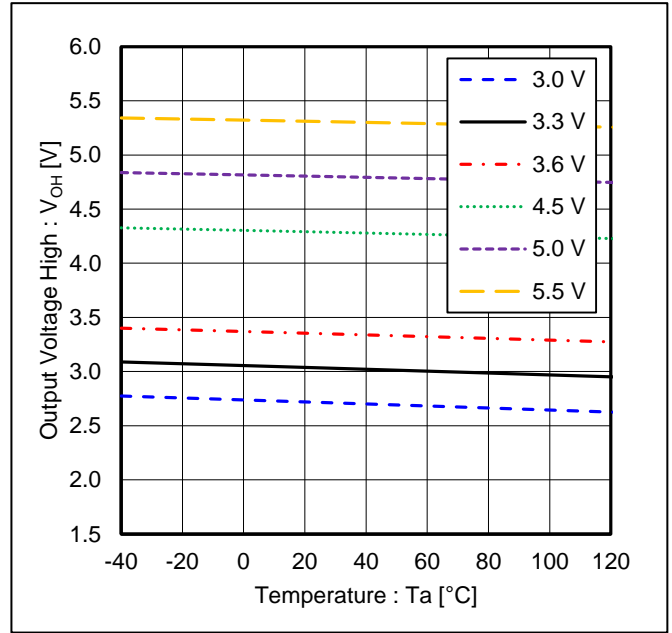

Figure 10. Output Voltage High vs Temperature (@I_{so} = -4 mA)

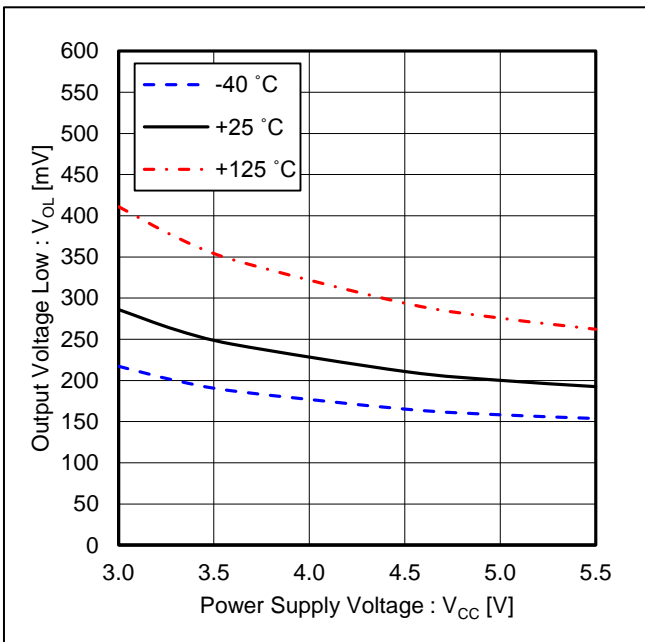

Figure 11. Output Voltage Low vs Power Supply Voltage (@I_{so} = 4 mA)

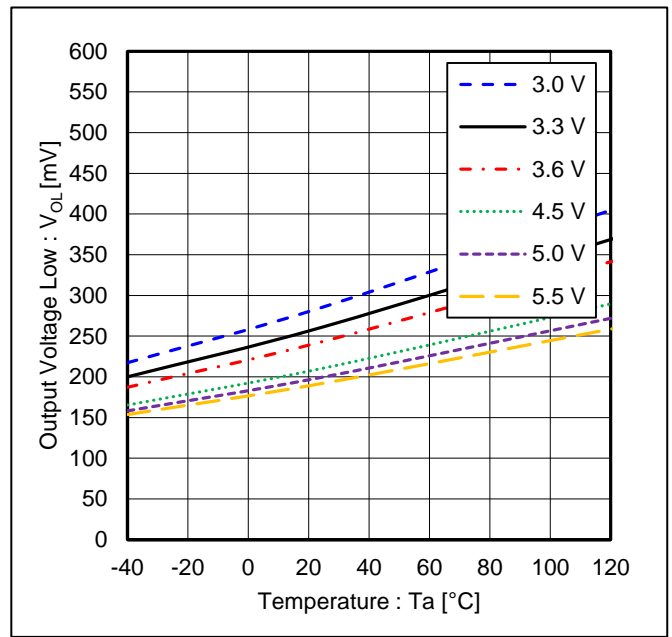

Figure 12. Output Voltage Low vs Temperature (@I_{so} = 4 mA)

Timing Chart of Input Signal

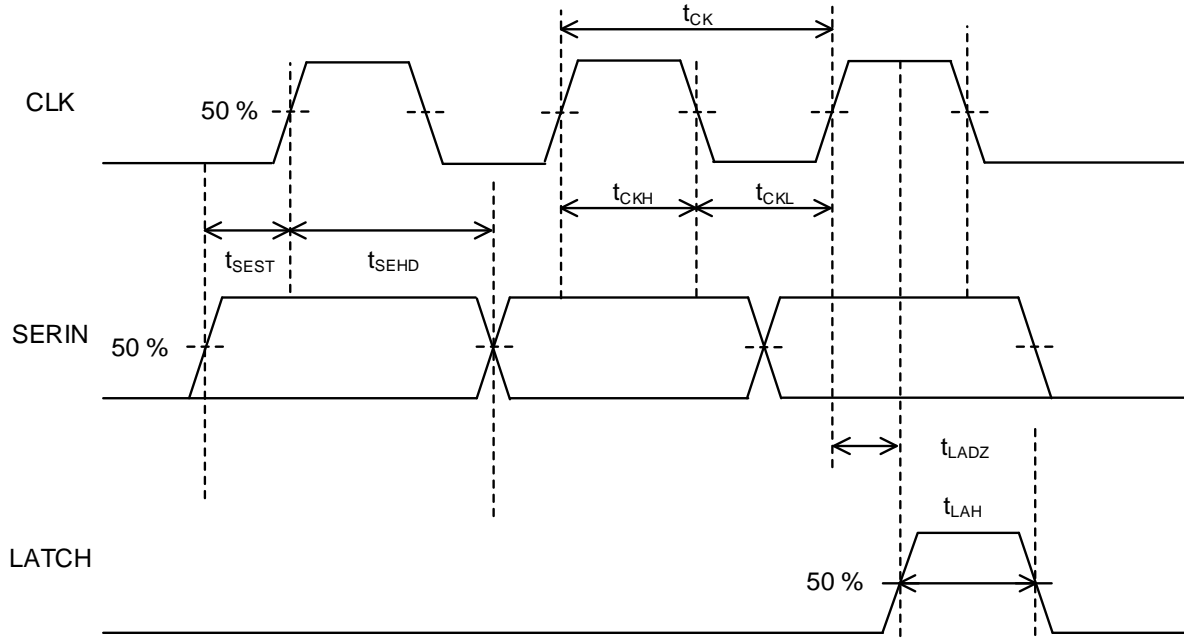

Figure 13. Timing Chart of Input Signal

Parameter	Symbol	Min	Unit
CLK Period	t_{CK}	800	ns
CLK High Pulse Width	t_{CKH}	380	ns
CLK Low Pulse Width	t_{CKL}	380	ns
SERIN High and Low Pulse Width	t_{SEW}	780	ns
SERIN Setup Time	t_{SEST}	150	ns
SERIN Hold Time	t_{SEHD}	150	ns
LATCH High Pulse Time	t_{LAH}	380	ns
Output DN Pin Setup Time ^(Note 1)	t_{LADZ}	200	ns

(Note 1) N: 0 to 11

Table 1. Timing Rules of Input Signal ($T_a = -40\text{ }^\circ\text{C}$ to $+125\text{ }^\circ\text{C}$, $V_{CC} = 3.0\text{ V}$ to 5.5 V)

Timing Chart of Output Signal

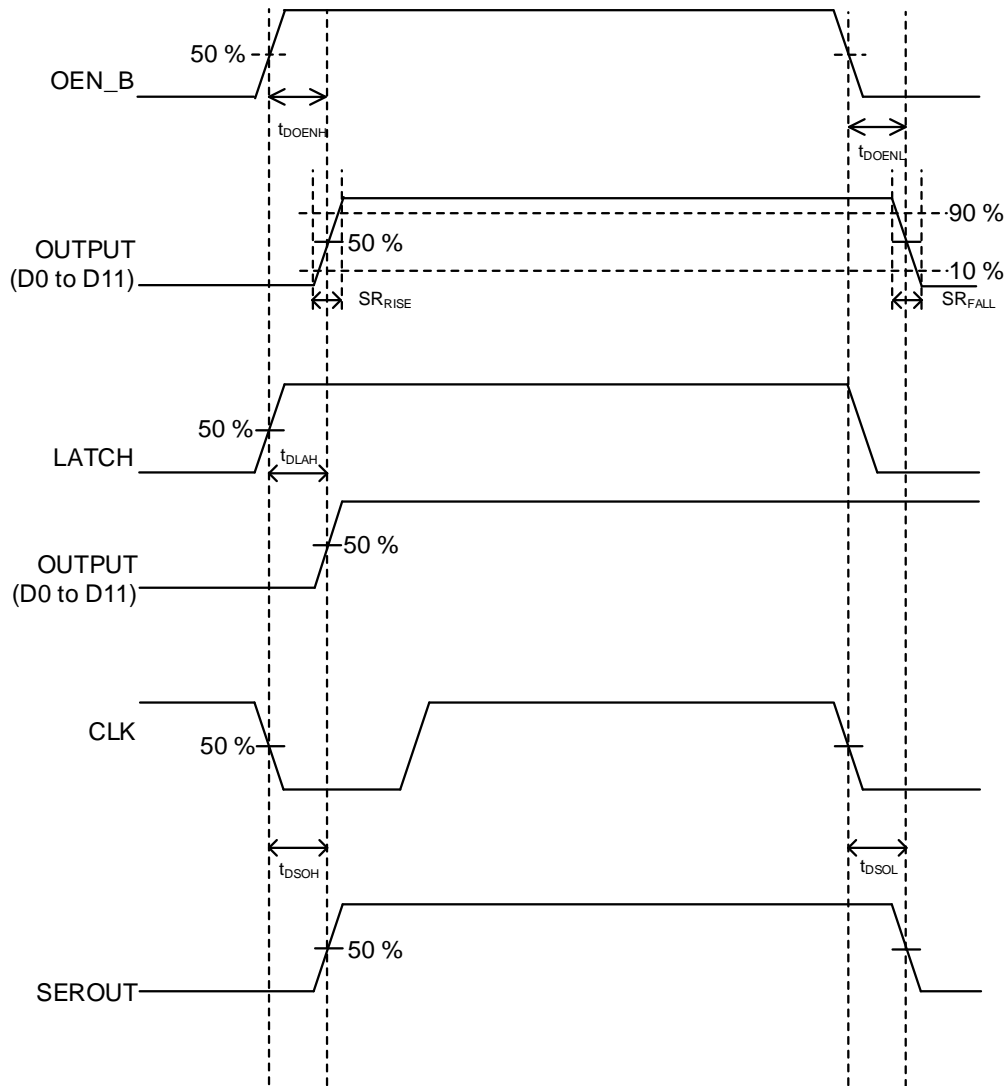

Figure 14. Timing Chart of Output Signal

Parameter	Symbol	Min	Typ	Max	Unit	Condition
OEN_B Switching Time (Low→High)	t_{DOENH}	-	-	3000	ns	
OEN_B Switching Time (High→Low)	t_{DOENL}	-	-	2000	ns	
LATCH Switching Delay Time	t_{DLAH}	-	-	3000	ns	
SEROUT Propagation Delay Time (Low→High)	t_{DSOH}	-	-	350	ns	
SEROUT Propagation Delay Time (High→Low)	t_{DSOL}	-	-	350	ns	
Output Rising Slew Rate ^(Note 1)	SR_{RISE}	-	20	-	V/μs	Ta = 25 °C, VCC = 5 V, RL = 500 Ω, VBAT = 10 V
Output Falling Slew Rate ^(Note 1)	SR_{FALL}	-	20	-	V/μs	Ta = 25 °C, VCC = 5 V, RL = 500 Ω, VBAT = 10 V

(Note 1) Refer to the Application Example on page 12 for measurement conditions. However, LED load is not used, and it is shorted.

Table 2. Delay Time of Output Signal (Ta = -40 °C to +125 °C, VCC = 3.0 V to 5.5 V)

Application Example

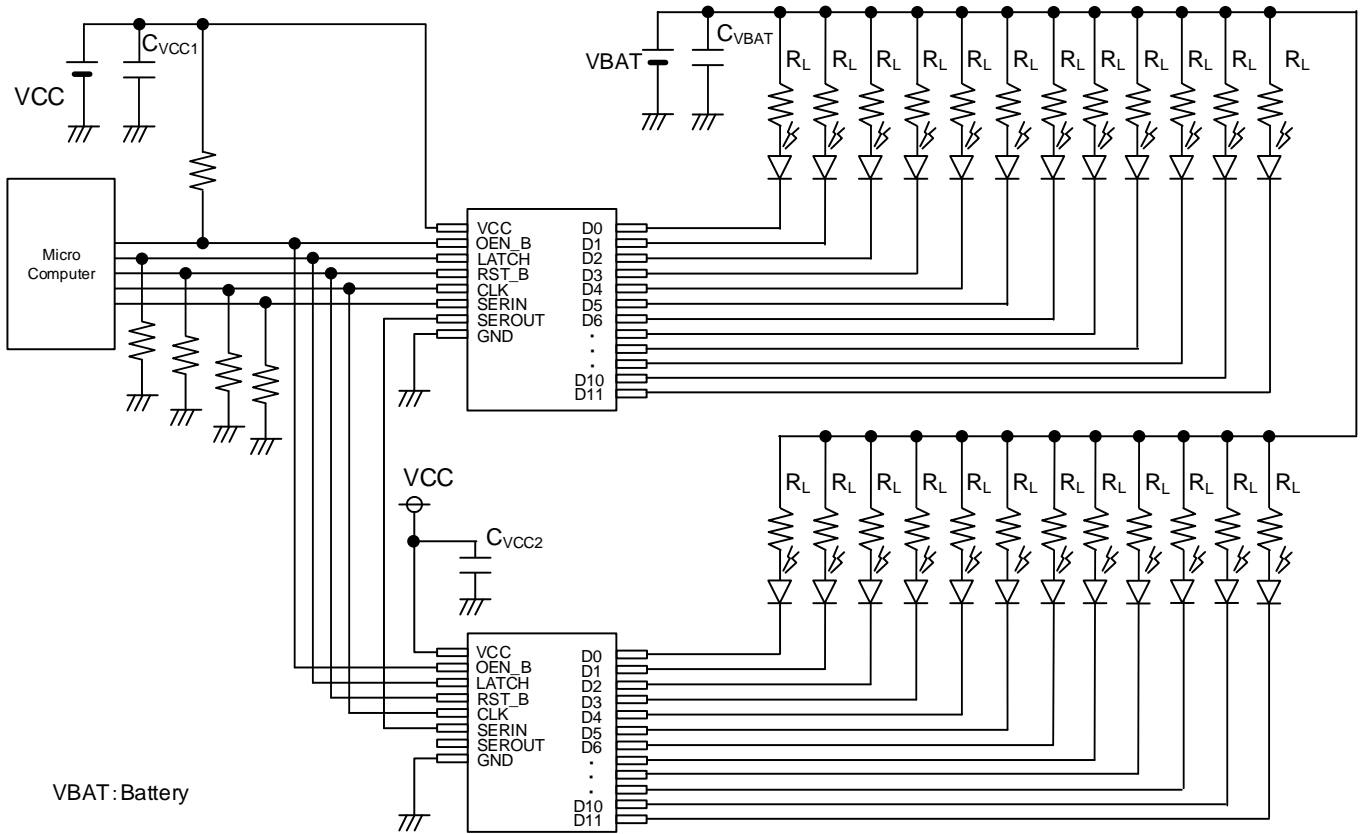

Figure 15. Application Example

Component Name	Component Value	Product Name	Manufacturer
C _{VCC1}	0.1 μF	GCM155R11A104KA01	murata
C _{VCC2}	0.1 μF	GCM155R11A104KA01	murata
C _{VBAT}	4.7 μF	GCM32ER71H475KA40	murata
R _L	620 Ω	ESR10EZPJ621	Rohm

Caution: When adding elements other than LEDs and resistors to the output DN pin for in-process inspection, care must be taken in the power-on sequence. Therefore, Inquire the application circuit. Also, be sure to limit the current by resistance to the output DN pin. (N: 0 to 11)

I/O Equivalence Circuit

<p>2. SERIN 12. LATCH</p> <p>9. RST_B 19. CLK</p> <p>10. OEN_B</p>	<p>3. D0 7. D4 15. D8</p> <p>4. D1 8. D5 16. D9</p> <p>5. D2 13. D6 17. D10</p> <p>6. D3 14. D7 18. D11</p>
<p>11. SEROUT</p>	<p>1. VCC 20. GND</p>

Operational Notes

1. Reverse Connection of Power Supply

Connecting the power supply in reverse polarity can damage the IC. Take precautions against reverse polarity when connecting the power supply, such as mounting an external diode between the power supply and the IC's power supply pins.

2. Power Supply Lines

Design the PCB layout pattern to provide low impedance supply lines. Furthermore, connect a capacitor to ground at all power supply pins. Consider the effect of temperature and aging on the capacitance value when using electrolytic capacitors.

3. Ground Voltage

Ensure that no pins are at a voltage below that of the ground pin at any time, even during transient condition.

4. Ground Wiring Pattern

When using both small-signal and large-current ground traces, the two ground traces should be routed separately but connected to a single ground at the reference point of the application board to avoid fluctuations in the small-signal ground caused by large currents. Also ensure that the ground traces of external components do not cause variations on the ground voltage. The ground lines must be as short and thick as possible to reduce line impedance.

5. Recommended Operating Conditions

The function and operation of the IC are guaranteed within the range specified by the recommended operating conditions. The characteristic values are guaranteed only under the conditions of each item specified by the electrical characteristics.

6. Inrush Current

When power is first supplied to the IC, it is possible that the internal logic may be unstable and inrush current may flow instantaneously due to the internal powering sequence and delays, especially if the IC has more than one power supply. Therefore, give special consideration to power coupling capacitance, power wiring, width of ground wiring, and routing of connections.

7. Testing on Application Boards

When testing the IC on an application board, connecting a capacitor directly to a low-impedance output pin may subject the IC to stress. Always discharge capacitors completely after each process or step. The IC's power supply should always be turned off completely before connecting or removing it from the test setup during the inspection process. To prevent damage from static discharge, ground the IC during assembly and use similar precautions during transport and storage.

8. Inter-pin Short and Mounting Errors

Ensure that the direction and position are correct when mounting the IC on the PCB. Incorrect mounting may result in damaging the IC. Avoid nearby pins being shorted to each other especially to ground, power supply and output pin. Inter-pin shorts could be due to many reasons such as metal particles, water droplets (in very humid environment) and unintentional solder bridge deposited in between pins during assembly to name a few.

9. Unused Input Pins

Input pins of an IC are often connected to the gate of a MOS transistor. The gate has extremely high impedance and extremely low capacitance. If left unconnected, the electric field from the outside can easily charge it. The small charge acquired in this way is enough to produce a significant effect on the conduction through the transistor and cause unexpected operation of the IC. So unless otherwise specified, unused input pins should be connected to the power supply or ground line.

Operational Notes - continued

10. Regarding the Input Pin of the IC

This monolithic IC contains P+ isolation and P substrate layers between adjacent elements in order to keep them isolated. P-N junctions are formed at the intersection of the P layers with the N layers of other elements, creating a parasitic diode or transistor. For example (refer to figure below):

When $GND > Pin A$ and $GND > Pin B$, the P-N junction operates as a parasitic diode.
 When $GND > Pin B$, the P-N junction operates as a parasitic transistor.

Parasitic diodes inevitably occur in the structure of the IC. The operation of parasitic diodes can result in mutual interference among circuits, operational faults, or physical damage. Therefore, conditions that cause these diodes to operate, such as applying a voltage lower than the GND voltage to an input pin (and thus to the P substrate) should be avoided.

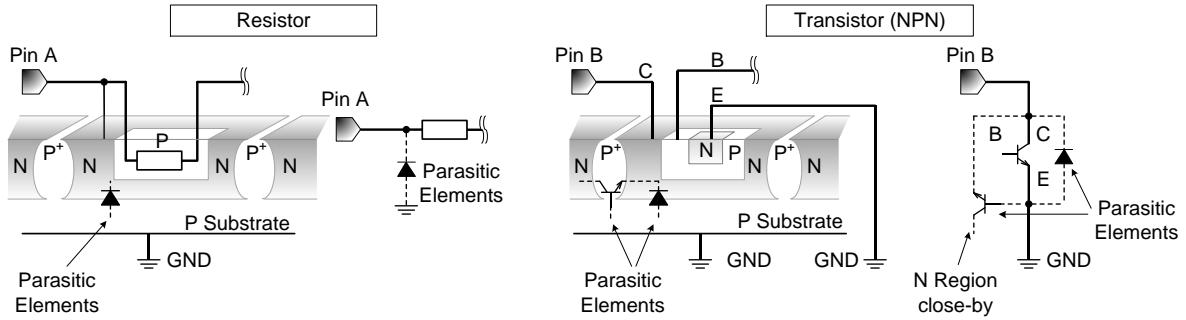
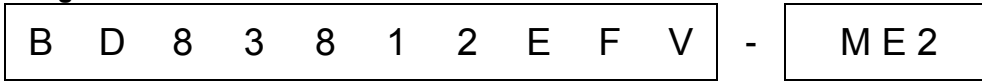

Figure 16. Example of monolithic IC structure

11. Ceramic Capacitor

When using a ceramic capacitor, determine a capacitance value considering the change of capacitance with temperature and the decrease in nominal capacitance due to DC bias and others.

Ordering Information



Package
EFV: HTSSOP-B20

Product rank
M: for Automotive
Packaging and forming specification
E2: Embossed tape and reel

Marking Diagram

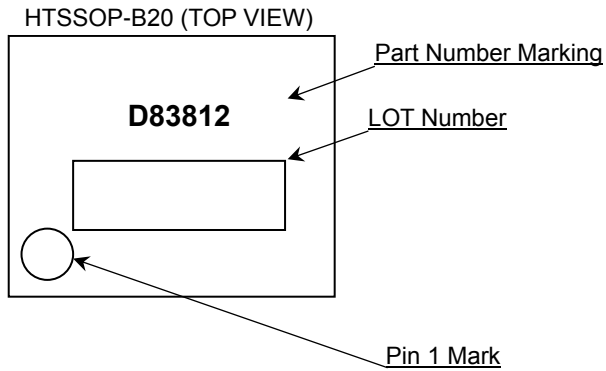

Physical Dimension and Packing Information

Package Name	HTSSOP-B20
--------------	------------

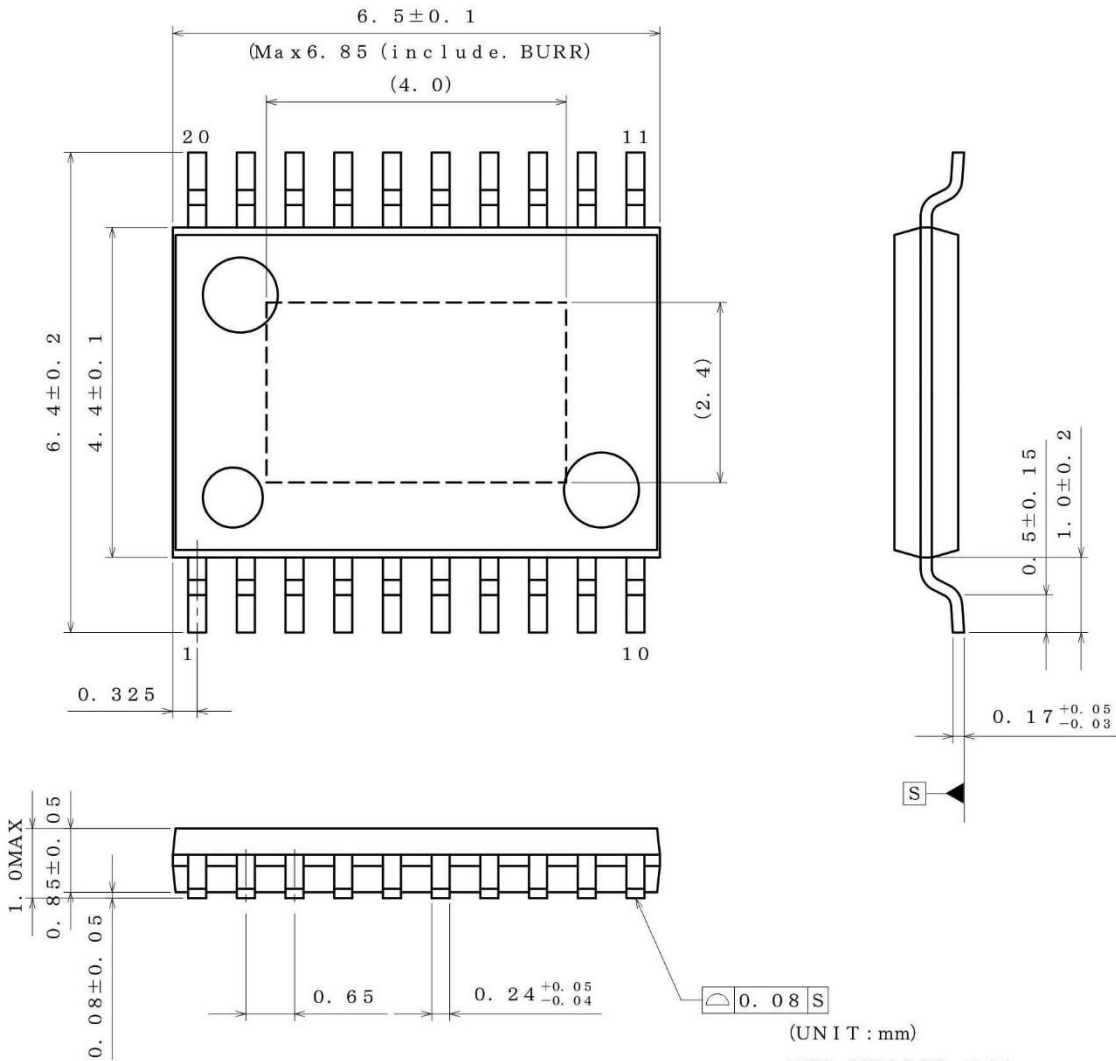

(UNIT : mm)
 PKG : HTSSOP-B20
 Drawing No. EX192-5002

< Tape and Reel Information >

Tape	Embossed carrier tape
Quantity	2500pcs
Direction of feed	E2 The direction is the pin 1 of product is at the upper left when you hold reel on the left hand and you pull out the tape on the right hand

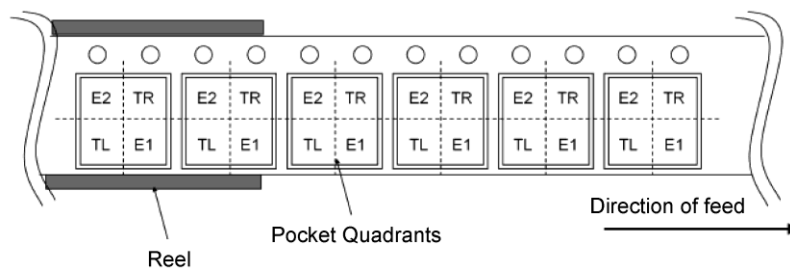

Revision History

Date	Rev.	Changes
18.Mar.2022	001	New Release

Notice

Precaution on using ROHM Products

1. If you intend to use our Products in devices requiring extremely high reliability (such as medical equipment ^(Note 1), aircraft/spacecraft, nuclear power controllers, etc.) and whose malfunction or failure may cause loss of human life, bodily injury or serious damage to property ("Specific Applications"), please consult with the ROHM sales representative in advance. Unless otherwise agreed in writing by ROHM in advance, ROHM shall not be in any way responsible or liable for any damages, expenses or losses incurred by you or third parties arising from the use of any ROHM's Products for Specific Applications.

(Note1) Medical Equipment Classification of the Specific Applications

JAPAN	USA	EU	CHINA
CLASS III	CLASS III	CLASS II b	CLASS III
CLASS IV		CLASS III	

2. ROHM designs and manufactures its Products subject to strict quality control system. However, semiconductor products can fail or malfunction at a certain rate. Please be sure to implement, at your own responsibilities, adequate safety measures including but not limited to fail-safe design against the physical injury, damage to any property, which a failure or malfunction of our Products may cause. The following are examples of safety measures:
 - [a] Installation of protection circuits or other protective devices to improve system safety
 - [b] Installation of redundant circuits to reduce the impact of single or multiple circuit failure
3. Our Products are not designed under any special or extraordinary environments or conditions, as exemplified below. Accordingly, ROHM shall not be in any way responsible or liable for any damages, expenses or losses arising from the use of any ROHM's Products under any special or extraordinary environments or conditions. If you intend to use our Products under any special or extraordinary environments or conditions (as exemplified below), your independent verification and confirmation of product performance, reliability, etc. prior to use, must be necessary:
 - [a] Use of our Products in any types of liquid, including water, oils, chemicals, and organic solvents
 - [b] Use of our Products outdoors or in places where the Products are exposed to direct sunlight or dust
 - [c] Use of our Products in places where the Products are exposed to sea wind or corrosive gases, including Cl₂, H₂S, NH₃, SO₂, and NO₂
 - [d] Use of our Products in places where the Products are exposed to static electricity or electromagnetic waves
 - [e] Use of our Products in proximity to heat-producing components, plastic cords, or other flammable items
 - [f] Sealing or coating our Products with resin or other coating materials
 - [g] Use of our Products without cleaning residue of flux (Exclude cases where no-clean type fluxes is used. However, recommend sufficiently about the residue.); or Washing our Products by using water or water-soluble cleaning agents for cleaning residue after soldering
 - [h] Use of the Products in places subject to dew condensation
4. The Products are not subject to radiation-proof design.
5. Please verify and confirm characteristics of the final or mounted products in using the Products.
6. In particular, if a transient load (a large amount of load applied in a short period of time, such as pulse, is applied, confirmation of performance characteristics after on-board mounting is strongly recommended. Avoid applying power exceeding normal rated power; exceeding the power rating under steady-state loading condition may negatively affect product performance and reliability.
7. De-rate Power Dissipation depending on ambient temperature. When used in sealed area, confirm that it is the use in the range that does not exceed the maximum junction temperature.
8. Confirm that operation temperature is within the specified range described in the product specification.
9. ROHM shall not be in any way responsible or liable for failure induced under deviant condition from what is defined in this document.

Precaution for Mounting / Circuit board design

1. When a highly active halogenous (chlorine, bromine, etc.) flux is used, the residue of flux may negatively affect product performance and reliability.
2. In principle, the reflow soldering method must be used on a surface-mount products, the flow soldering method must be used on a through hole mount products. If the flow soldering method is preferred on a surface-mount products, please consult with the ROHM representative in advance.

For details, please refer to ROHM Mounting specification

Precautions Regarding Application Examples and External Circuits

1. If change is made to the constant of an external circuit, please allow a sufficient margin considering variations of the characteristics of the Products and external components, including transient characteristics, as well as static characteristics.
2. You agree that application notes, reference designs, and associated data and information contained in this document are presented only as guidance for Products use. Therefore, in case you use such information, you are solely responsible for it and you must exercise your own independent verification and judgment in the use of such information contained in this document. ROHM shall not be in any way responsible or liable for any damages, expenses or losses incurred by you or third parties arising from the use of such information.

Precaution for Electrostatic

This Product is electrostatic sensitive product, which may be damaged due to electrostatic discharge. Please take proper caution in your manufacturing process and storage so that voltage exceeding the Products maximum rating will not be applied to Products. Please take special care under dry condition (e.g. Grounding of human body / equipment / solder iron, isolation from charged objects, setting of Ionizer, friction prevention and temperature / humidity control).

Precaution for Storage / Transportation

1. Product performance and soldered connections may deteriorate if the Products are stored in the places where:
 - [a] the Products are exposed to sea winds or corrosive gases, including Cl₂, H₂S, NH₃, SO₂, and NO₂
 - [b] the temperature or humidity exceeds those recommended by ROHM
 - [c] the Products are exposed to direct sunshine or condensation
 - [d] the Products are exposed to high Electrostatic
2. Even under ROHM recommended storage condition, solderability of products out of recommended storage time period may be degraded. It is strongly recommended to confirm solderability before using Products of which storage time is exceeding the recommended storage time period.
3. Store / transport cartons in the correct direction, which is indicated on a carton with a symbol. Otherwise bent leads may occur due to excessive stress applied when dropping of a carton.
4. Use Products within the specified time after opening a humidity barrier bag. Baking is required before using Products of which storage time is exceeding the recommended storage time period.

Precaution for Product Label

A two-dimensional barcode printed on ROHM Products label is for ROHM's internal use only.

Precaution for Disposition

When disposing Products please dispose them properly using an authorized industry waste company.

Precaution for Foreign Exchange and Foreign Trade act

Since concerned goods might be fallen under listed items of export control prescribed by Foreign exchange and Foreign trade act, please consult with ROHM in case of export.

Precaution Regarding Intellectual Property Rights

1. All information and data including but not limited to application example contained in this document is for reference only. ROHM does not warrant that foregoing information or data will not infringe any intellectual property rights or any other rights of any third party regarding such information or data.
2. ROHM shall not have any obligations where the claims, actions or demands arising from the combination of the Products with other articles such as components, circuits, systems or external equipment (including software).
3. No license, expressly or implied, is granted hereby under any intellectual property rights or other rights of ROHM or any third parties with respect to the Products or the information contained in this document. Provided, however, that ROHM will not assert its intellectual property rights or other rights against you or your customers to the extent necessary to manufacture or sell products containing the Products, subject to the terms and conditions herein.

Other Precaution

1. This document may not be reprinted or reproduced, in whole or in part, without prior written consent of ROHM.
2. The Products may not be disassembled, converted, modified, reproduced or otherwise changed without prior written consent of ROHM.
3. In no event shall you use in any way whatsoever the Products and the related technical information contained in the Products or this document for any military purposes, including but not limited to, the development of mass-destruction weapons.
4. The proper names of companies or products described in this document are trademarks or registered trademarks of ROHM, its affiliated companies or third parties.

General Precaution

1. Before you use our Products, you are requested to carefully read this document and fully understand its contents. ROHM shall not be in any way responsible or liable for failure, malfunction or accident arising from the use of any ROHM's Products against warning, caution or note contained in this document.
2. All information contained in this document is current as of the issuing date and subject to change without any prior notice. Before purchasing or using ROHM's Products, please confirm the latest information with a ROHM sales representative.
3. The information contained in this document is provided on an "as is" basis and ROHM does not warrant that all information contained in this document is accurate and/or error-free. ROHM shall not be in any way responsible or liable for any damages, expenses or losses incurred by you or third parties resulting from inaccuracy or errors of or concerning such information.