

A-002. Boost PFC Vin=200V, Iin=2.5A, CCM

Simulation Parameters

Component name	Component	Default	Simulation Setting Range
Vin	Input voltage	200Vac 50Hz	
Iin	Input current	2.5Aac	
Vo	Output voltage	400Vdc	300 – 500Vdc
fsw	Switching frequency	100kHz	10k – 300k
Tj	Temperature	100°C	
Vd	Gate Drive voltage	18V	10 – 20V

Devices

Component name	Component	Default	Simulation Setting Range
Q1	SiC MOSFET	Selectable	
D1	SiC SBD	Selectable	
GD-IC	Gate Driver	BM61S41RFV-C	
R sink	Resistor for sink	2Ω	0.1 -
R source	Resistor for source	5Ω	0.1 -
L1	Inductor	150μH	10μH - 1mH
C1	Capacitor	200nF	
BR	Bridge Diode	600V 10A ideal diode	

Simulation Circuit

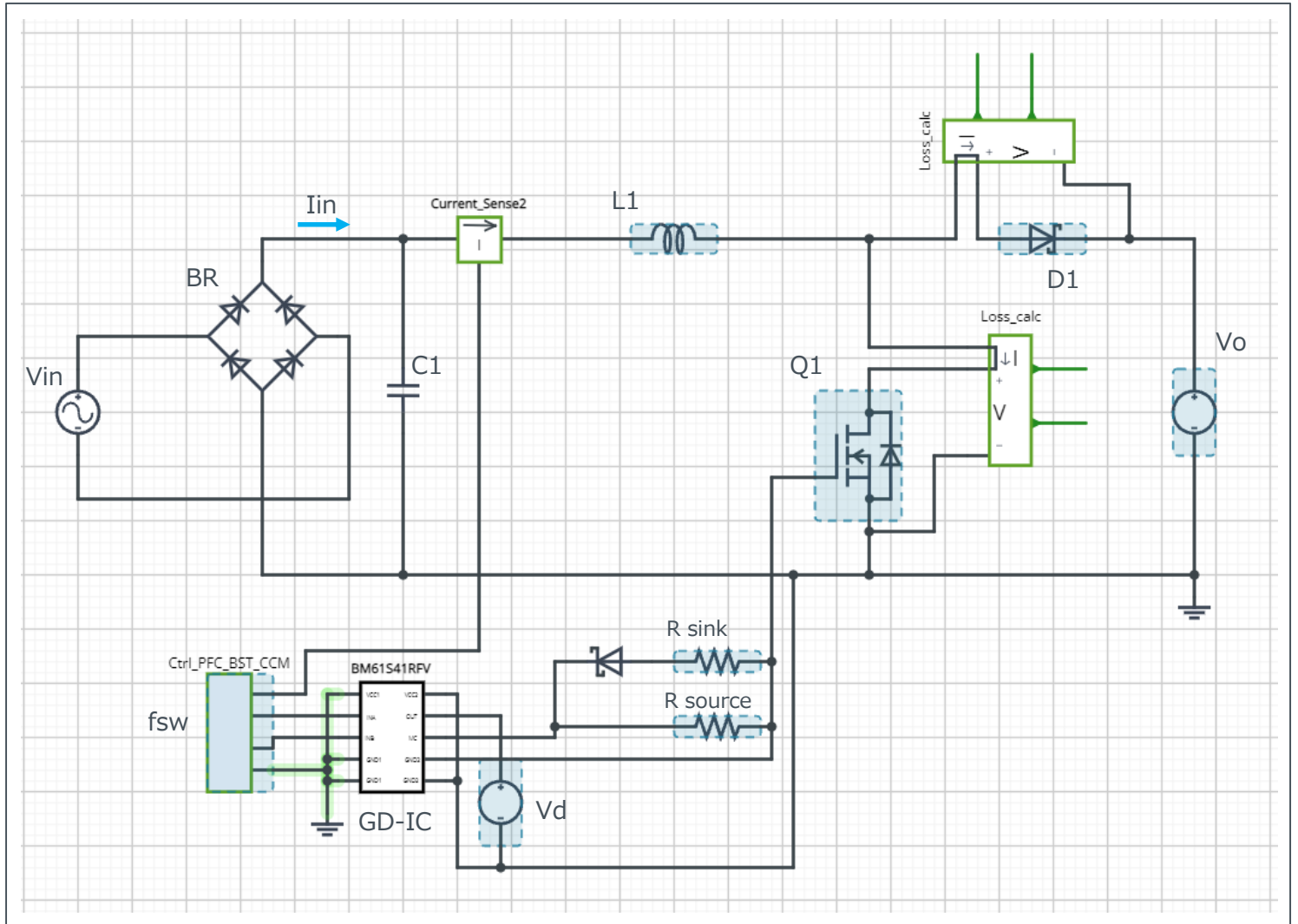

Note: The Loss_calc component is a utility module to support power loss calculation, and does not affect the simulation results of circuit operation or performance.

A-002. Boost PFC $V_{in}=200V$, $I_{in}=2.5A$, CCM



2021. Oct
64UG061E Rev.003

Selectable Devices

Component name	Component	Product No.	feature
Q1	SiC MOSFET	SCT2080KE	1200V, 80mΩ, 40A
		SCT2120AF	650V, 120mΩ, 29A
		SCT2160KE	1200V, 160mΩ, 22A
		SCT2280KE	1200V, 280mΩ, 14A
		SCT2450KE (*)	1200V, 450mΩ, 10A
		SCT2750NY	1700V, 750mΩ, 6A
		SCT2H12NZ	1700V, 1150mΩ, 3.7A
		SCT3017AL	650V, 17mΩ, 118A
		SCT3022AL	650V, 22mΩ, 93A
		SCT3022KL	1200V, 22mΩ, 95A
		SCT3030AL	650V, 30mΩ, 70A
		SCT3030KL	1200V, 30mΩ, 72A
		SCT3040KL	1200V, 40mΩ, 55A
		SCT3060AL	650V, 60mΩ, 39A
		SCT3080AL	650V, 80mΩ, 30A
		SCT3080KL	1200V, 80mΩ, 31A
		SCT3105KL	1200V, 105mΩ, 24A
		SCT3120AL	650V, 120mΩ, 21A
		SCT3160KL	1200V, 160mΩ, 17A

* Default device

Selectable Devices

Component name	Component	Product No.	feature
D1	SiC SBD	SCS205KG	1200V, 5A
		SCS206AG	650V, 6A
		SCS208AG	650V, 8A
		SCS210AG	650V, 10A
		SCS210KG	1200V, 10A
		SCS212AG	650V, 12A
		SCS215AG	650V, 15A
		SCS215KG	1200V, 15A
		SCS220AG	650V, 20A
		SCS220KG	1200V, 20A
		SCS302AHG (*)	650V, 2A, High surge resistance
		SCS304AHG	650V, 4A, High surge resistance
		SCS306AHG	650V, 6A, High surge resistance
		SCS308AHG	650V, 8A, High surge resistance
		SCS310AHG	650V, 10A, High surge resistance
		SCS312AHG	650V, 12A, High surge resistance
		SCS315AHG	650V, 15A, High surge resistance
		SCS320AHG	650V, 20A, High surge resistance

* Default device

How to change the devices

Right-click on the device → Select Properties → Pull down “SpiceLib Part” → Select the product

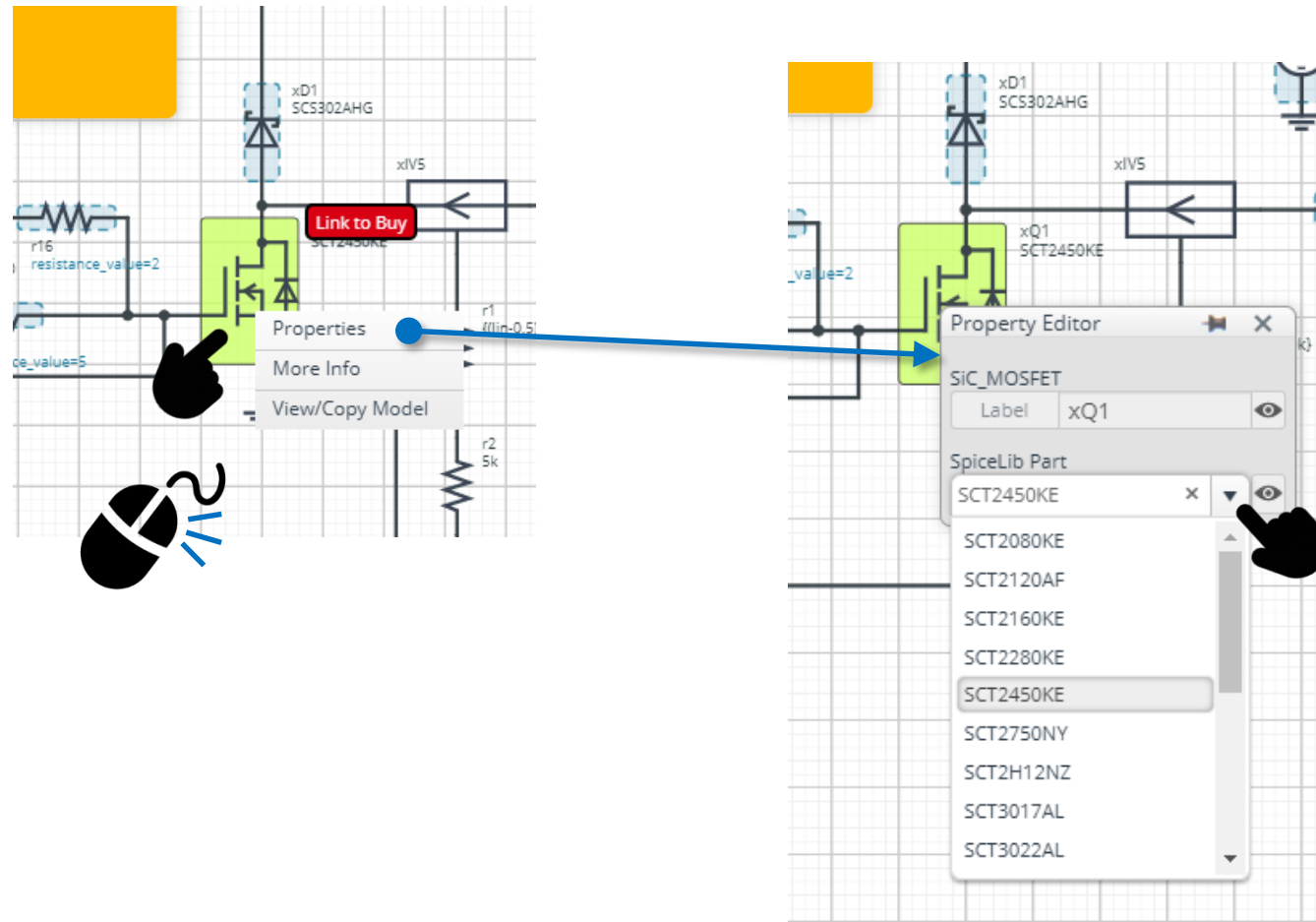

Notes

- 1) The information contained herein is subject to change without notice.
- 2) Before you use our Products, please contact our sales representative and verify the latest specifications :
- 3) Although ROHM is continuously working to improve product reliability and quality, semiconductors can break down and malfunction due to various factors.
Therefore, in order to prevent personal injury or fire arising from failure, please take safety measures such as complying with the derating characteristics, implementing redundant and fire prevention designs, and utilizing backups and fail-safe procedures. ROHM shall have no responsibility for any damages arising out of the use of our Products beyond the rating specified by ROHM.
- 4) Examples of application circuits, circuit constants and any other information contained herein are provided only to illustrate the standard usage and operations of the Products. The peripheral conditions must be taken into account when designing circuits for mass production.
- 5) The technical information specified herein is intended only to show the typical functions of and examples of application circuits for the Products. ROHM does not grant you, explicitly or implicitly, any license to use or exercise intellectual property or other rights held by ROHM or any other parties. ROHM shall have no responsibility whatsoever for any dispute arising out of the use of such technical information.
- 6) The Products specified in this document are not designed to be radiation tolerant.
- 7) For use of our Products in applications requiring a high degree of reliability (as exemplified below), please contact and consult with a ROHM representative : transportation equipment (i.e. cars, ships, trains), primary communication equipment, traffic lights, fire/crime prevention, safety equipment, medical systems, servers, solar cells, and power transmission systems.
- 8) Do not use our Products in applications requiring extremely high reliability, such as aerospace equipment, nuclear power control systems, and submarine repeaters.
- 9) ROHM shall have no responsibility for any damages or injury arising from non-compliance with the recommended usage conditions and specifications contained herein.
- 10) ROHM has used reasonable care to ensure the accuracy of the information contained in this document. However, ROHM does not warrants that such information is error-free, and ROHM shall have no responsibility for any damages arising from any inaccuracy or misprint of such information.
- 11) Please use the Products in accordance with any applicable environmental laws and regulations, such as the RoHS Directive. For more details, including RoHS compatibility, please contact a ROHM sales office. ROHM shall have no responsibility for any damages or losses resulting non-compliance with any applicable laws or regulations.
- 12) When providing our Products and technologies contained in this document to other countries, you must abide by the procedures and provisions stipulated in all applicable export laws and regulations, including without limitation the US Export Administration Regulations and the Foreign Exchange and Foreign Trade Act.
- 13) This document, in part or in whole, may not be reprinted or reproduced without prior consent of ROHM.



Thank you for your accessing to ROHM product informations.
More detail product informations and catalogs are available, please contact us.

ROHM Customer Support System

<http://www.rohm.com/contact/>