

B-004-HSD. 1-Phase 2-level Full Bridge Inverter $P_{OUT}=20kW$ (Equipped with HSDIP20 Package)



ROHM Solution Simulator Schematic Information

2026. Mar
68UG096E Rev.001

Simulation Parameters

Component name	Component	Default	Simulation Setting Range
Vin	Input voltage	500Vdc	
Vo	Output voltage	200Vac	
Io	Output current	100Aac	
fsw	Switching frequency	20kHz	10k – 300kHz
Tj	Temperature	100°C	
Vd1-4+	Gate Drive voltage H	18V	
Vd1-4-	Gate Drive voltage L	0V	
Vdin	Signal voltage level	5V	

Devices

Component Name	Component	Default	Simulation Setting Range
Q1	SiC Power Module	Selectable	
GD-IC1-4	Gate Driver	BM61S41RFV-C	
R sink1-4	Resistor for sink	ESR18 5Ω	
R source1-4	Resistor for source	ESR18 5Ω	
L1	Inductor	500μH	10μH - 2mH
Ro	Output Resistor	{Vo/Io}	

Simulation Circuit

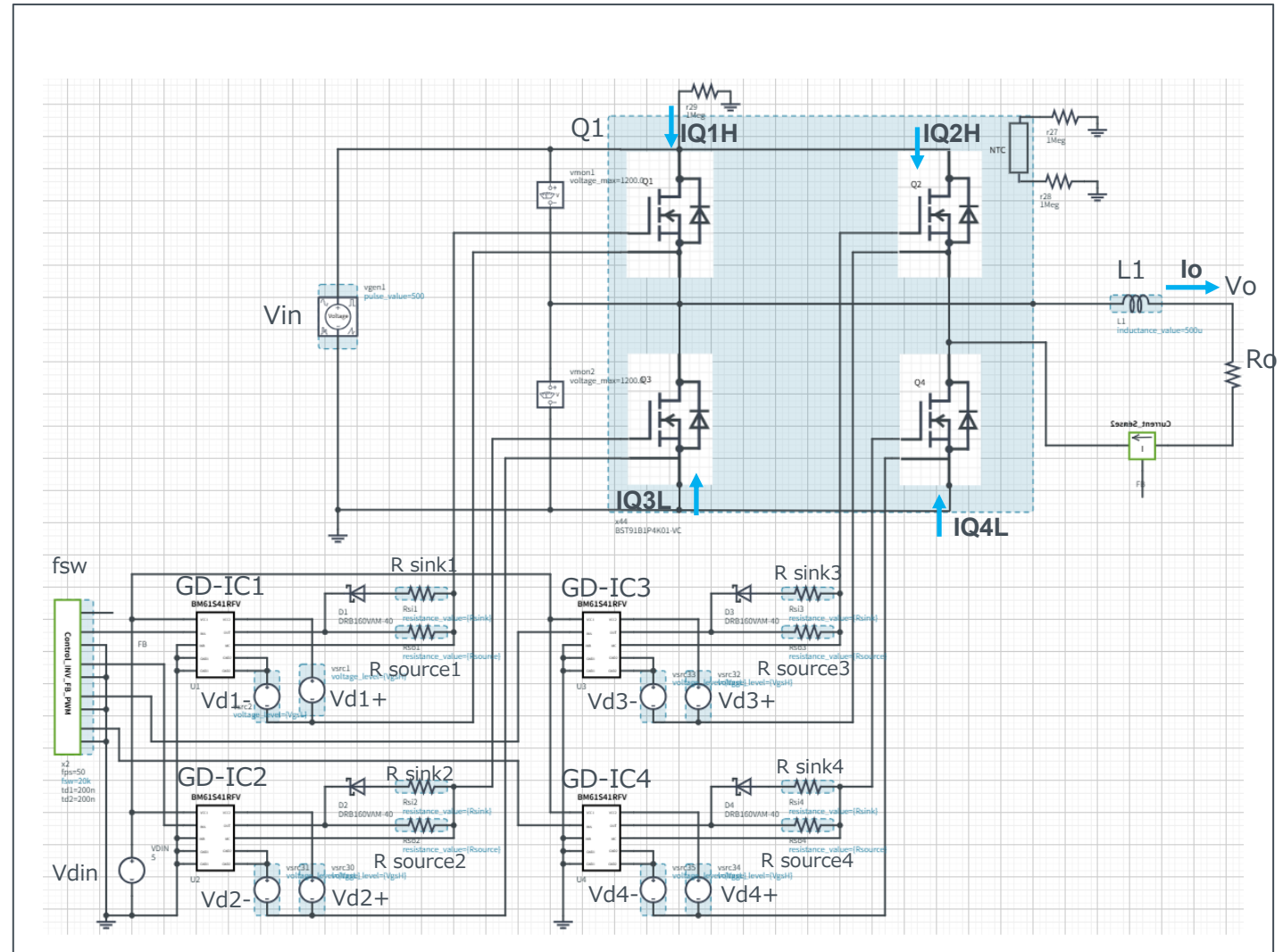

Note: The Loss_calc component is a utility module to support power loss calculation and does not affect the simulation results of circuit operation or performance.

B-004-HSD. 1-Phase 2-level Full Bridge Inverter $P_{OUT}=20kW$ (Equipped with HSDIP20 Package)



ROHM Solution Simulator Schematic Information

2026. Mar
68UG096E Rev.001

Selectable Devices

Component name	Component
Q1	SiC Power Module (HSDIP20)

For more information, go to “**More Info**” and click on “**Link to Datasheet**”.

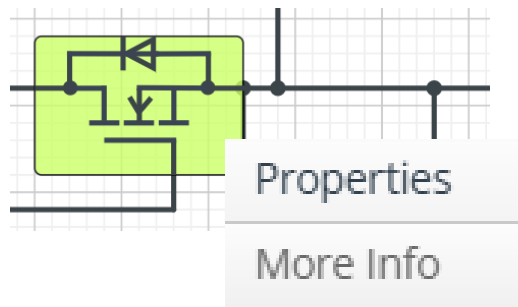

Model Links:
[Link To Product](#)
[Link To Datasheet](#)
[Link To Buy](#)
[Search on CSE...](#)

SiC Power Module part number information

B S T 9 1 B 1 P 4 K 0 1 - V C

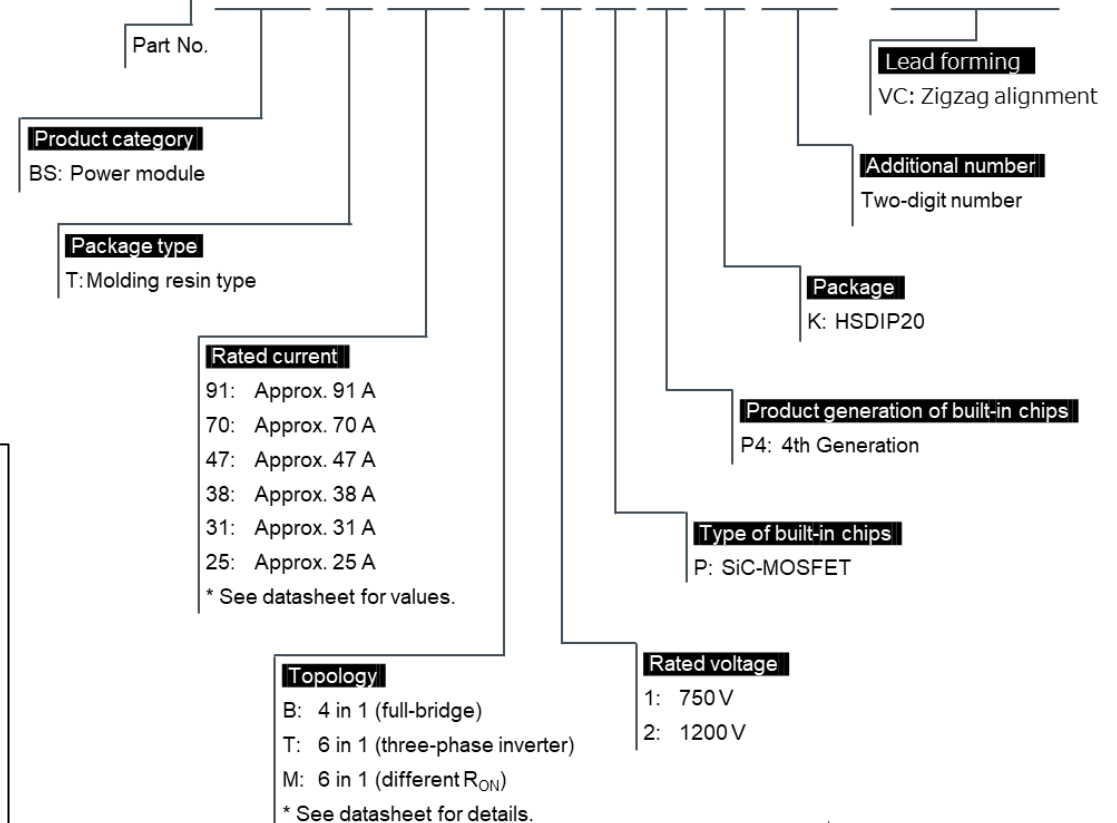

Product Lineup: [SiC Power Module](#)

B-004-HSD. 1-Phase 2-level Full Bridge Inverter $P_{OUT}=20kW$ (Equipped with HSDIP20 Package)



ROHM Solution Simulator Schematic Information

2026. Mar
68UG096E Rev.001

Selectable Devices

Component name	Component	Product No.	feature
GD-IC1-4	Gate Driver	BM61S41RFV-C	for SiC MOSFET Isolation Voltage : 3750 Vrms I/O Delay Time (max) : 65ns Miller Clamp : Built-in UVLO : 14.5V

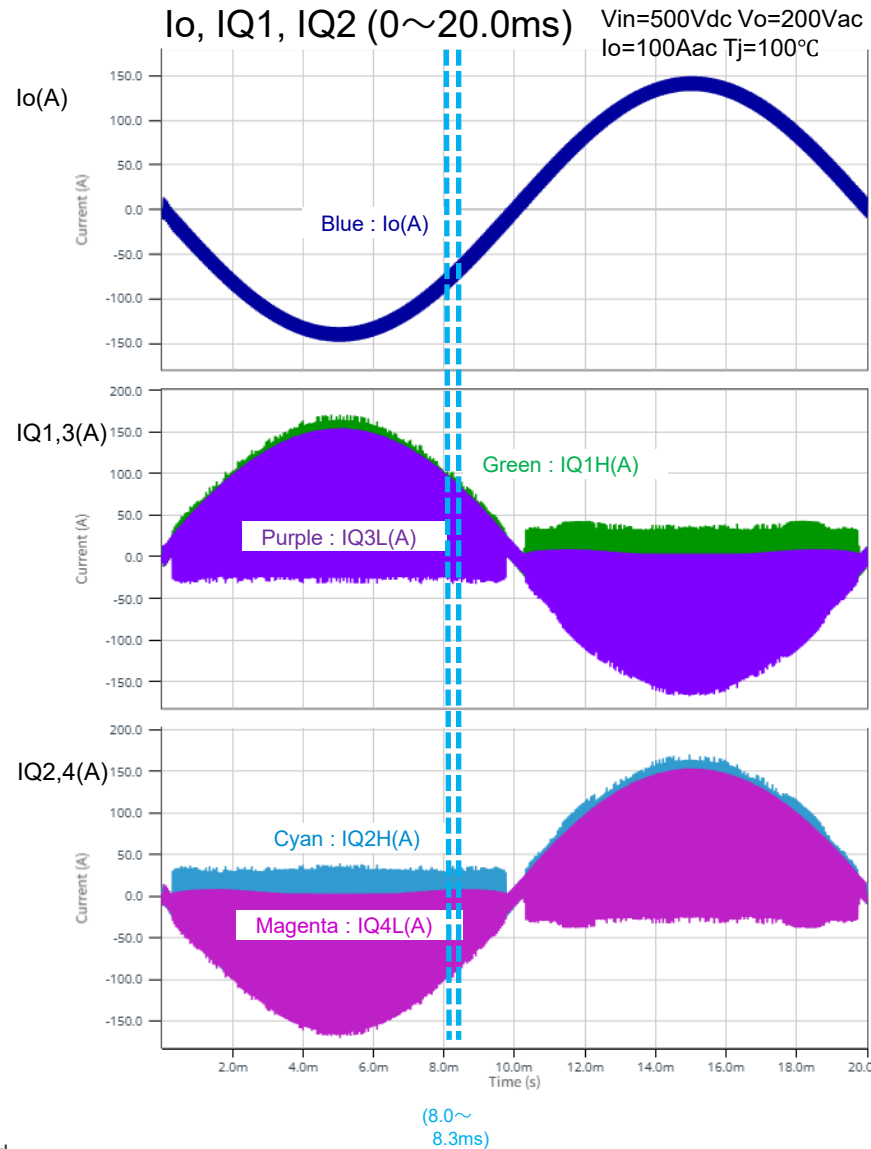

Expansion (8.0~8.3ms)

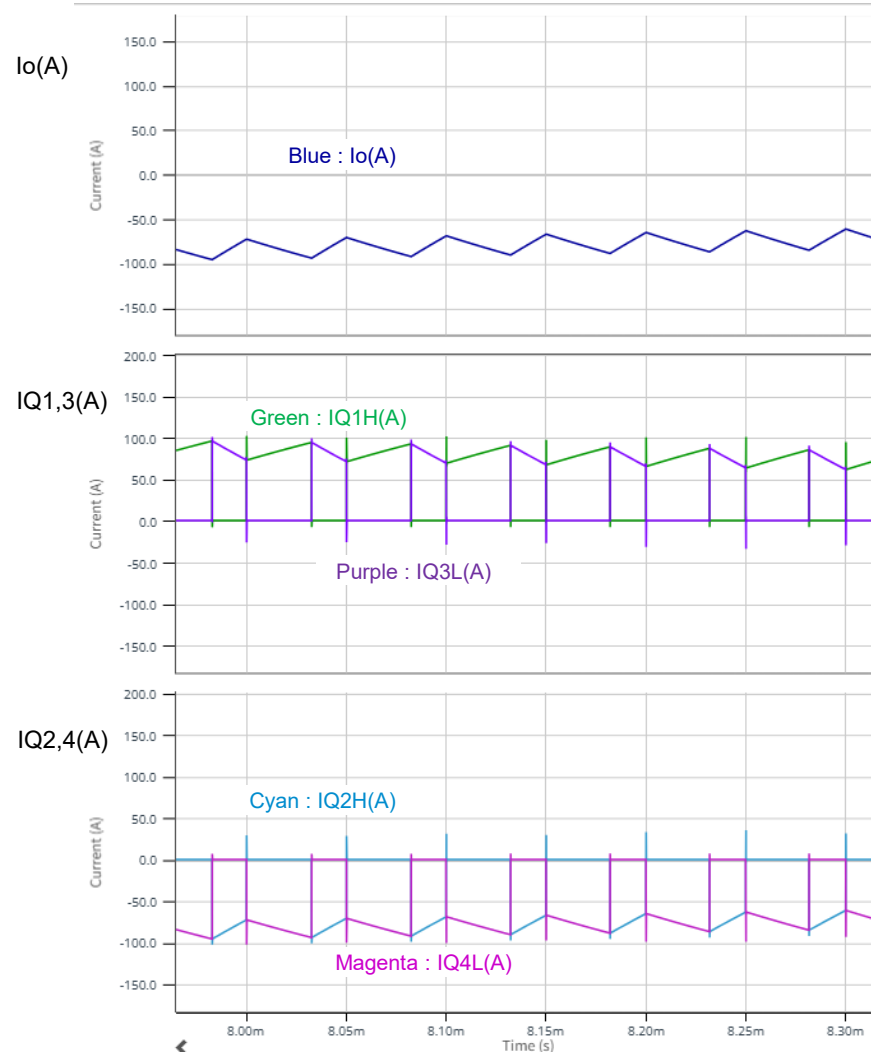

How to change the devices

Right-click on the device → Select Properties → Pull down “SpiceLib Part” → Select the product

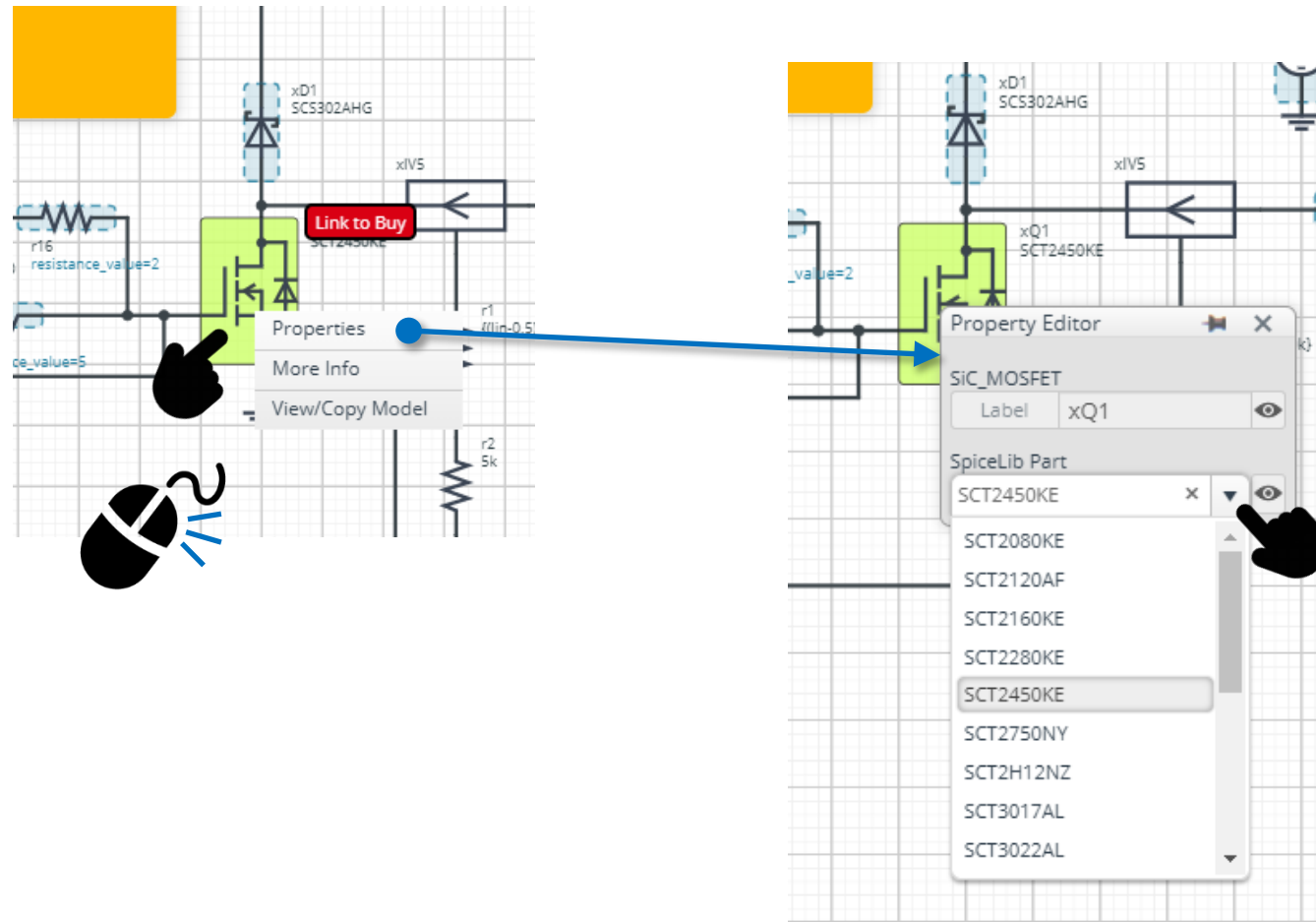

Loss Calculation Model outputs the instantaneous value of power loss and its integration.

Loss calculation model 'Loss_calc'

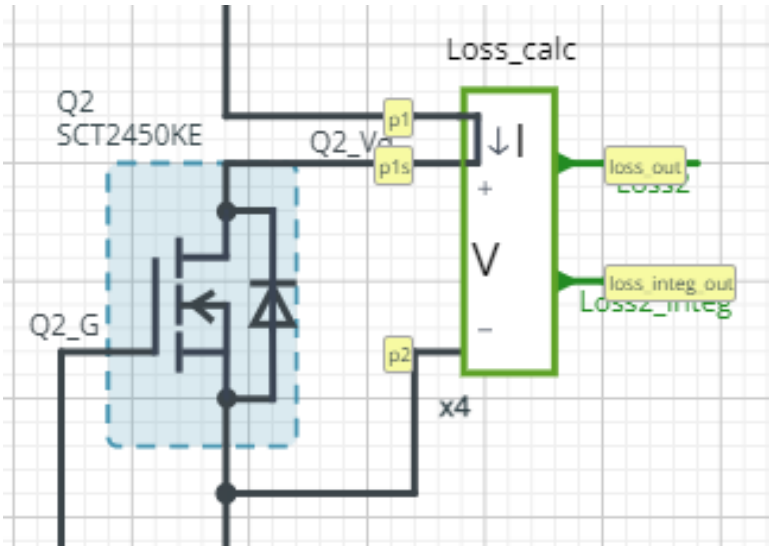

$$loss_out(t) = I(t) \times V(t)$$

$$loss_integ_out = \int_0^t loss_out(t) dt$$

I : Current through p1 to p1s

V : Voltage between p1s and p2

Waveform example

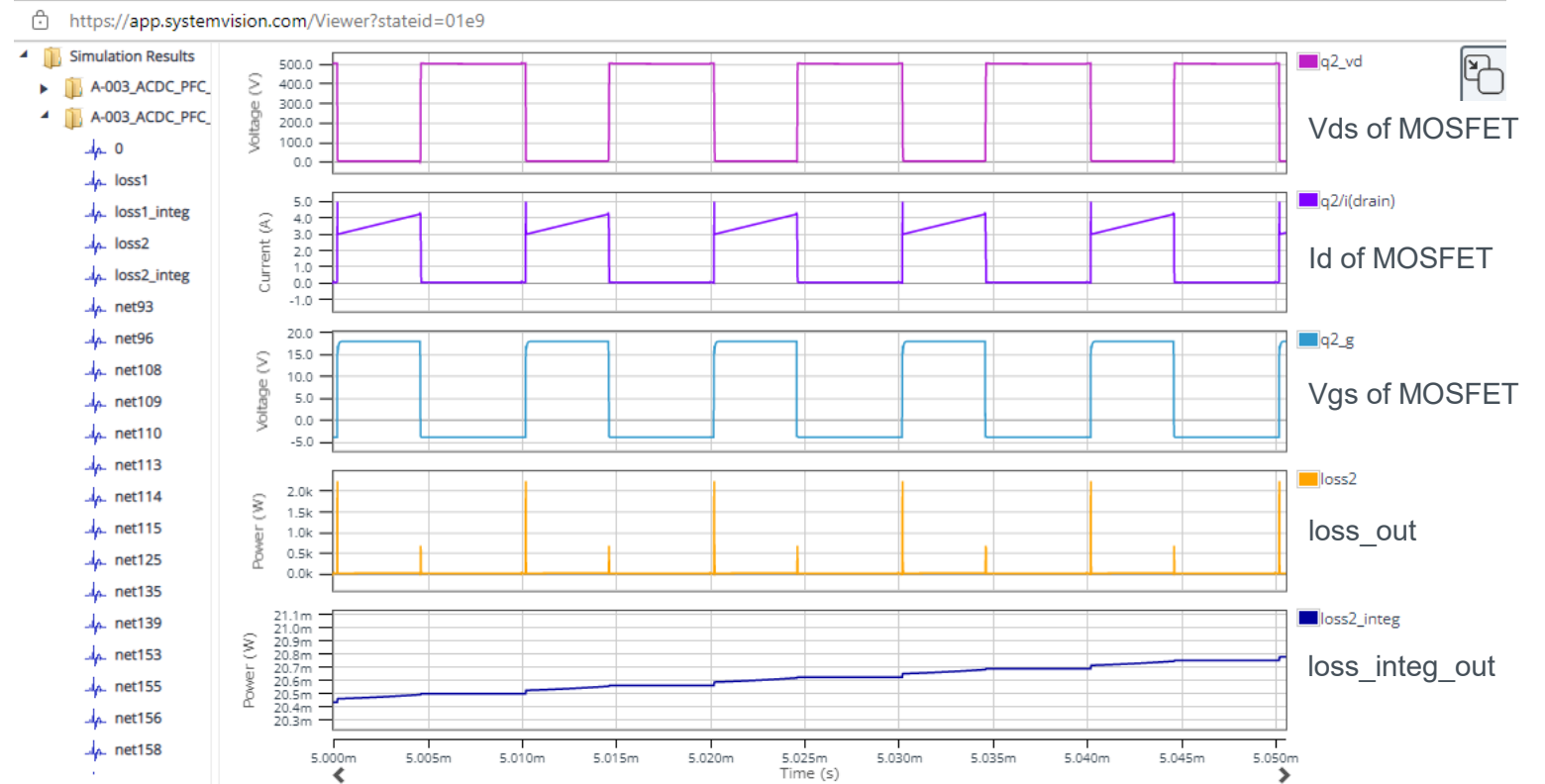

Notice

- 1) The information contained in this document is intended to introduce ROHM Group (hereafter referred to as ROHM) products. When using ROHM products, please verify the latest specifications or datasheets before use.
- 2) ROHM products are designed and manufactured for use in general electronic equipment and applications (such as Audio Visual equipment, Office Automation equipment, telecommunication equipment, home appliances, amusement devices, etc.) or specified in the datasheets. Therefore, please contact the ROHM sales representative before using ROHM products in equipment or devices requiring extremely high reliability and whose failure or malfunction may cause danger or injury to human life or body or other serious damage (such as medical equipment, transportation, traffic, aircraft, spacecraft, nuclear power controllers, fuel control, automotive equipment including car accessories, etc. hereafter referred to as Specific Applications). Unless otherwise agreed in writing by ROHM in advance, ROHM shall not be in any way responsible or liable for any damages, expenses, or losses incurred by you or third parties arising from the use of ROHM Products for Specific Applications.
- 3) Electronic components, including semiconductors, can fail or malfunction at a certain rate. Please be sure to implement, at your own responsibilities, adequate safety measures including but not limited to fail-safe design against physical injury, and damage to any property, which a failure or malfunction of products may cause.
- 4) The information contained in this document, including application circuit examples and their constants, is intended to explain the standard operation and usage of ROHM products, and is not intended to guarantee, either explicitly or implicitly, the operation of the product in the actual equipment it will be used. As a result, you are solely responsible for it, and you must exercise your own independent verification and judgment in the use of such information contained in this document. ROHM shall not be in any way responsible or liable for any damages, expenses, or losses incurred by you or third parties arising from the use of such information.
- 5) When exporting ROHM products or technologies described in this document to other countries, you must abide by the procedures and provisions stipulated in all applicable export laws and regulations, such as the Foreign Exchange and Foreign Trade Act and the US Export Administration Regulations, and follow the necessary procedures in accordance with these provisions.
- 6) The technical information and data described in this document, including typical application circuits, are examples only and are not intended to guarantee to be free from infringement of third parties intellectual property or other rights. ROHM does not grant any license, express or implied, to implement, use, or exploit any intellectual property or other rights owned or controlled by ROHM or any third parties with respect to the information contained herein.
- 7) No part of this document may be reprinted or reproduced in any form by any means without the prior written consent of ROHM.
- 8) All information contained in this document is current as of the date of publication and subject to change without notice. Before purchasing or using ROHM products, please confirm the latest information with the ROHM sales representative.
- 9) ROHM does not warrant that the information contained herein is error-free. ROHM shall not be in any way responsible or liable for any damages, expenses, or losses incurred by you or third parties resulting from errors contained in this document.



Thank you for your accessing to ROHM product informations.
More detail product informations and catalogs are available, please contact us.

ROHM Customer Support System

<https://www.rohm.com/contactus>