

ROHM Solution Simulator

Current Sensing Circuit

High-Side Circuit Breaker - Thermal Co-simulation -

This circuit simulates the current shutdown response at the high-side current sensing with Current Sense Amplifier, Shunt resistor, and MOSFET. The voltage drop across the Shunt resistor is amplified by the Current Sense Amplifier to turn off the MOSFET. You can change the Shunt resistor and MOSFET products.

You can also simulate the temperature rise of the Shunt resistor and MOSFET until the high current caused by the short-circuit event to turn off. The time required for the Current Sense Amplifier to shut down high current is extremely short time, making it very difficult to measure the temperature rise in the actual application board.

This simulation enables effective pre-verification in the design of current sensing circuits. Please refer to these application notes:

[Design Guide of Current Sensing Circuit Using Shunt Resistor](#),

[Thermal Evaluation of Current Sensing Circuit Using Shunt Resistor](#)

Contents

1.	Simulation schematic	2
2.	How to simulate	2
3.	Simulation conditions	3
4.	Thermal domain setting.....	4
5.	Current Sense Amplifier model	5
6.	MOSFET model	6
7.	Shunt resistor model	7
8.	Bill of Material	8
9.	Recommend Products and Application Notes	8

General Cautions

Caution 1: The values from the simulation results are not guaranteed. Please use these results as a guide for your design.

Caution 2: These model characteristics are specifically at Ta=100°C. Thus, the simulation result with temperature variances may significantly differ from the result obtained from an actual application board (actual measurement).

Caution 3: Please refer to the Application note of Current Sensing Circuit for details of the technical information.

Caution 4: The characteristics may change depending on the actual board design and ROHM strongly recommend to double check those characteristics with actual board where the devices will be mounted.

1. Simulation schematic

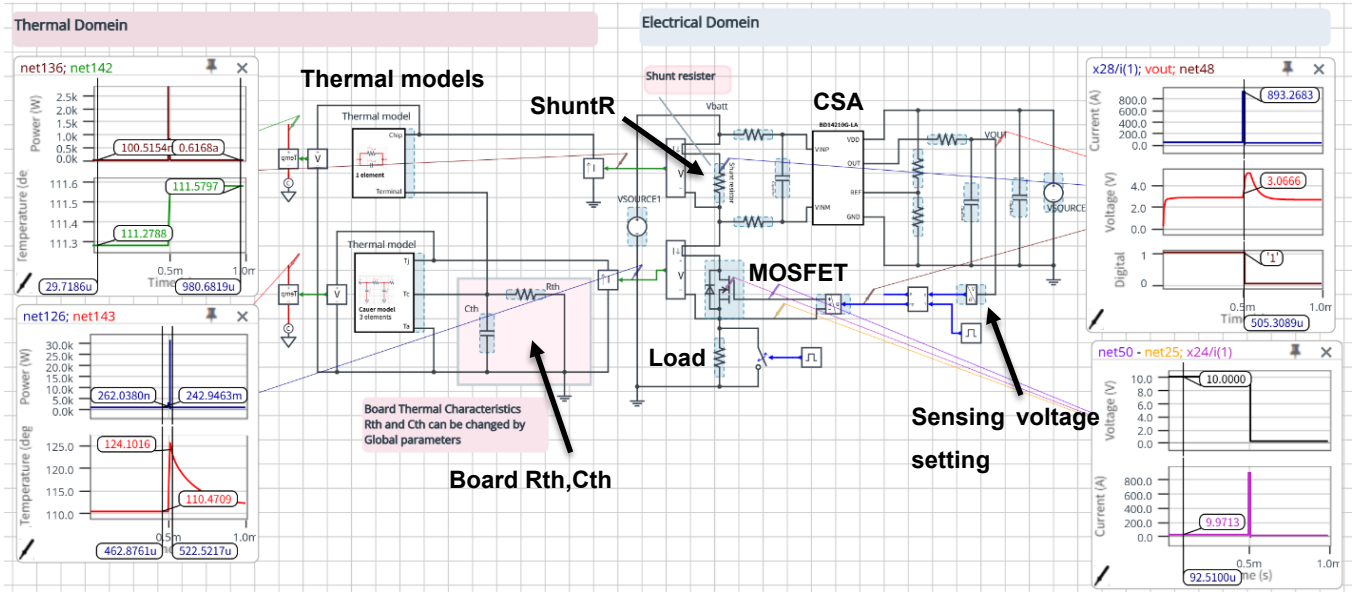

Figure 1. Simulation Schematic

The electrical domain area indicates the electrical simulation circuit, and the thermal domain area indicates the thermal simulation circuit. The Spice model and thermal model for the MOSFET and Shunt resistor can be changed by double-clicking. The box filled in with red Rth and Cth values in the thermal domain define the board's thermal resistance and thermal capacitance. You can input your assumed board conditions to verify the temperature rise. You can customize the parameters of the components shown in blue.

2. How to simulate

The simulation settings, such as parameter sweep or convergence options, are configurable from the 'Simulation Settings' shown in Figure 2, and Table 1 shows the default setup of the simulation. In case of simulation convergence issue, you can change advanced options to solve. You can easily change the settings listed under the "Manual Options" by double-clicking the "Global Parameters" in the green box.

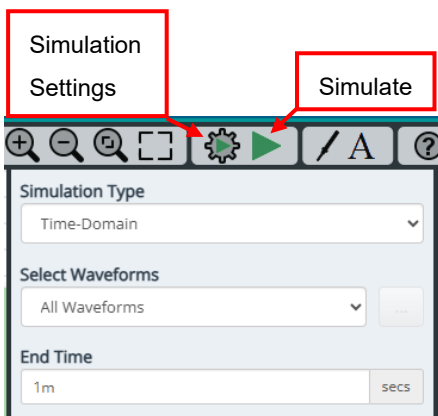

Figure 2. Simulation Settings and execution

Table 1. Simulation settings default setup

Parameters	Default	Note
Simulation Type	Time-Domain	Do not change Simulation Type
Select Waveforms	All Waveforms	Waveforms can be viewed at any node after simulation.
End time	1ms	-
Advanced options	Simulation Resolution	1e-7
	Convergence Assist	-
Manual Options	TEMP=100 decC Rth_board=25 K/W Cth_board=5 Ws/K	You can change the values in the Global Parameters window.

3. Simulation conditions

Table 2. List of the simulation condition parameters

Instance Name	Type	Parameters	Default Value	Variable Range		Units
				Min	Max	
VSOURCE1	Voltage Source	Voltage_level	12	free		V
		AC_magnitude	0.0	fixed		V
		AC_phase	0.0	fixed		deg
VSOURCE2	Voltage Source	Voltage_level	5	2.7V to 5.5V ^(Note1)		V
		AC_magnitude	0.0	fixed		V
		AC_phase	0.0	fixed		deg
Load	Resistor	Resistance Value	1.2 ^(Note2)	free		Ω
Sensing Voltage	Voltage to Digital	Threshold	4.1 ^(Not3)	free		V

(Note 1) Set it to the operating range of the Current Sense Amplifier.

(Note 2) Set the resistance value to match the steady-state current. The default setting is $12V/1.2\Omega = 10A$.

(Note 3) ■ **Current Sense Amplifier Sensing Voltage setting**

$$V_{out} = (R_{shunt} \times I_{load} \times GAIN) + V_{ref}$$

R_{shunt} is the Shunt resistance value

I_{load} is the Load current

$GAIN$ is the Gain of Current Sense Amplifier

V_{ref} is the REF pin voltage

Example setting

BD14210G-LA : GAIN=20 V/V, Vref=2.5V

Shunt resistor : PSR330ITQFH1L00 (1mΩ)

Iload (shutdown current): 80A

4. Thermal domain setting

You can check the temperature rise from the probe installed in the Temp component until the high current is shutdown. Thermal models can be changed by double-clicking. **Ensure the thermal models for the Shunt resistor and MOSFET match the product specified in the Electrical Domain.**

The red-framed Rth and Cth represent the thermal resistance and thermal capacitance of the board. Double-click "Global Parameters" in the green box to change the value. You can verify the required thermal resistance value for the board before prototyping.

Default Setting

Rth_board=25 K/W, Cth_board=5 Ws/K

These values are tentatively defined by ROHM based on the thermal simulation result of PCB specified in the Table3

Global Parameters		
Name	Value	Description
Rth_board	25	PCB thermal resistance
Cth_board	5	PCB thermal capacitance
Tj	100	Junction Temperature

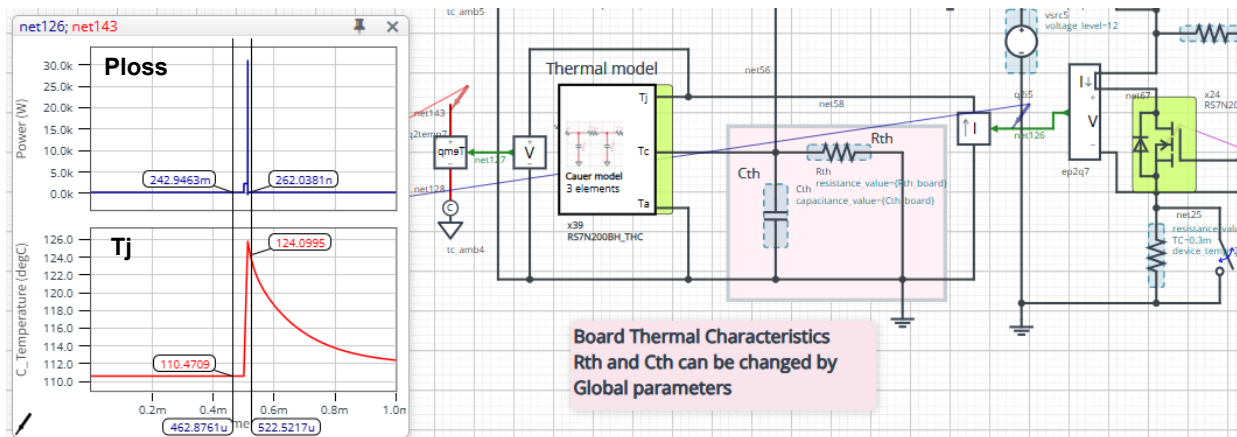

Figure 3. Global parameters, PCB thermal resistance and thermal capacitance

Table 3. PCB specifications

Item	Value
Board thickness	1.6mm
Board outline dimensions	82.1mm x 73.9mm
Board material	FR4
Number of layers	2-layers
Copper thickness	70µm (2oz)
Copper foil area	Top:800mm ² Bottom:1300mm ²

5. Current Sense Amplifier model

Table 4 shows list of the selectable Current Sense Amplifier models. Table 5 shows the model terminal function implemented. Note that Current Sense Amplifier model is the behavior model for current sensing circuit, and no protection circuits or the functions not related to the purpose are not implemented.

Table 4. Current Sense Amplifier model list

Grade	Product No.	Feature
Automotive	BD14220G-C	Gain= 25 V/V
	BD14221G-C	Gain= 50 V/V
	BD14222G-C	Gain= 100 V/V
Industrial	BD14210G-LA	Gain= 20 V/V

Table 5. Current Sense Amplifier model terminals used for the simulation

Terminals	Description
VINP	Input of supply side of shunt resistor
VINM	Input of load side of shunt resistor
VDD	Power supply
OUT	Current detection output
REF	Reference input
GND	Ground

6. MOSFET model

MOSFETs can be changed by double-clicking.

Please refer to the following model name explanation.

[Part Explanation](#)

Single type

RD3H045SPFRA

Part No. **ROHM**

Id

001: 0.1A
 002: 0.2A
 :
 010: 1.0A
 :
 100: 10A
 :
 250: 25A

Grade

None: Standard
 FRA: Automotive
 HRB: Automotive
 HZG: Automotive

Package

A1: DSN1006-3 (SMM1006)
 D3: TO-252
 E1: SOT416FL (EMF3F)
 F4: DFN2020-8S (HUML2020L8)
 F5: SOT-323T (TUMT3)
 F6: SOT-363T (TUMT6)
 F9: DFN2020Y7LSAA
 H6: HSMT8
 H7: DFN3333T8LSAB
 J1: TO-263AB (LPTL)
 Q1: HSMT8
 Q3: HSMT8AG
 Q5: SOT-346T (TSMT3)
 Q6: SOT-457T (TSMT6)
 Q7: HSMT8
 S1: HSOP8S (HSOP8)
 S3: SOP8
 S6: HSOP8S (HSOP8)
 U1: SOT-323FL (UMT3F)
 V1: DFN0806-3 (VML0806)
 V2: DFN1006-3 (VML1006)
 V3: DFN0604-3 (VML0604)
 V4: DFN1616-6W
 V5: DFN1616-6
 V7: DFN1212-3
 V8: DFN1010-3W
 W4: DFN1616-7T (HEML1616L7)
 X3: TO-220AB

Vdss

A: 12V
 C: 20V
 E: 30V
 G: 40V
 H: 45V
 J: 50V
 L: 60V
 N: 80V
 P: 100V
 R: 150V
 S: 190V
 T: 200V
 U: 250V

Specifications and drive voltage

Symbol	Process	Polarity	Drive voltage	Comment
YN	1st Gen	Nch	0.9V	
UN	1st Gen	Nch	1.2V, 1.5V	
AA	1st Gen	Nch	10V	For Automotive
CN	1st Gen	Nch	10V	
SN	1st Gen	Nch	2.5V, 4.0V	
BE	3rd Gen	Nch	10V	
MN	3rd Gen	Nch	4.5V	High Performance
BD	3rd Gen	Nch	6.0V	
AD	4th Gen	Nch	4.5V	Built-in ESD Protection
BN	4th Gen	Nch	4.5V	
GN	4th Gen	Nch	4.5V	High Performance
AJ	5th Gen	Nch	2.5V	
BG	6th Gen	Nch	4.5V	
BH	6th Gen	Nch	6.0V, 10V	
BK	6th Gen	Nch	4.5V	For Automotive
BL	6th Gen	Nch	6.0V	For Automotive
SP	1st Gen	Pch	2.5V, 4.0V	
ZP	2nd Gen	Pch	1.2V, 1.5V	
RP	2nd Gen	Pch	4.0V	
AP	4th Gen	Pch	1.5V	
BC	5th Gen	Pch	1.8V	
AT	5th Gen	Pch	4.5V, 6.0V	
BJ	5th Gen	Pch	4.5V	For Automotive
LD	CSP	Nch	2.5V	

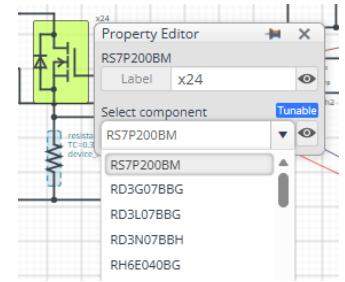

Figure 4. How to change MOSFET

7. Shunt resistor model

Shunt resistors can be changed by double-clicking.

Please refer to the following model name explanation.

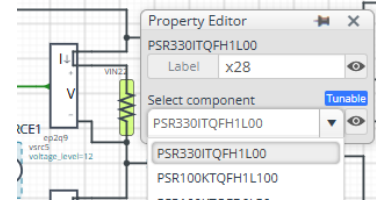

Figure 5. How to change Shunt resistor

Part No.	Size		Resistance (mΩ)	Tolerance	Special code	Rated power P (Rated terminal temperature T _R)		Temperature coefficient (ppm/°C)	Operating temperature range (°C)	Automotive grade available (AEC-Q200)
	(mm)	(inch)								
PSR100	6432	2512	0.2	F (±1%)	C	12W (130°C)		150±50	-65 ~+175	Yes
			0.3		D	8W (75°C)	4W (140°C)	0~+150		
			0.5		F	8W (75°C)	4W (140°C)	0~+100		
			1.0		H	8W (75°C)	4W (140°C)	0~+50		
			2.0		J	6W (75°C)	4W (140°C)			
			3.0		L	4W (75°C)	3W (140°C)			
PSR330	6464	2525	0.1	F (±1%)	B	15W (130°C)		100±50	-65 ~+175	Yes
			☆ 0.5		F	8W (100°C)		0 ~+100		
			☆ 1.0		H	6W (100°C)		0 ~+50		
PSR350	7.9×5.6	3222	0.27	F (±1%)	CW	12W (120°C)		0~+150	-65 ~+175	Yes
PSR400	10×5.2	3921	0.2	F (±1%)	C	12W (75°C)	5W (130°C)	125±50	-65 ~+175	Yes
			0.3		D	10W (75°C)	5W (130°C)	0~+100		
			0.5		F	10W (75°C)	5W (130°C)			
			1.0		H	8W (75°C)	5W (130°C)	0~+75		
			2.0		J	6W (75°C)	4W (115°C)			
			3.0		L	5W (70°C)	3W (115°C)			
PSR500	15×7.75	5931	0.1	F (±1%)	B	15W (75°C)	10W (120°C)	200±50	-65 ~+175	Yes
			0.2		C	15W (75°C)	10W (120°C)	0~+150		
			0.3		D	10W (75°C)	7W (120°C)			
			0.4		E	10W (75°C)	7W (120°C)	0~+75		
			0.5		F	10W (75°C)	7W (120°C)			
			1.0		H	10W (75°C)	6W (120°C)			
			2.0		J	7W (70°C)	4W (115°C)			

PSR	100	KTQ	F	H	1L00																																																																																												
Part No.	Size	Packaging code	Tolerance	Special code	Nominal resistance																																																																																												
<table border="1"> <thead> <tr> <th>Part No.</th> <th>Size</th> <th>(mm)</th> <th>[inch]</th> </tr> </thead> <tbody> <tr> <td>100</td> <td>(6432)</td> <td>[2512]</td> <td></td> </tr> <tr> <td>330</td> <td>(6464)</td> <td>[2525]</td> <td></td> </tr> <tr> <td>350</td> <td>(7.9×5.6)</td> <td>[3222]</td> <td></td> </tr> <tr> <td>400</td> <td>(10×5.2)</td> <td>[3921]</td> <td></td> </tr> <tr> <td>500</td> <td>(15×7.75)</td> <td>[5931]</td> <td></td> </tr> </tbody> </table>	Part No.	Size	(mm)	[inch]	100	(6432)	[2512]		330	(6464)	[2525]		350	(7.9×5.6)	[3222]		400	(10×5.2)	[3921]		500	(15×7.75)	[5931]		<table border="1"> <thead> <tr> <th>Type</th> <th>Code</th> <th>Packaging specification</th> <th>Quantity pcs/Reel</th> </tr> </thead> <tbody> <tr> <td rowspan="2">PSR100</td> <td>ITQ^{*1}</td> <td>Embossed tape (8mm Pitch)</td> <td>3,000</td> </tr> <tr> <td>KTQ^{*2}</td> <td>Embossed tape (8mm pitch)</td> <td>5,000</td> </tr> <tr> <td>PSR330</td> <td>ITQ</td> <td>Embossed tape (8mm pitch)</td> <td>3,000</td> </tr> <tr> <td>PSR350</td> <td>KTQ</td> <td>Embossed tape (8mm Pitch)</td> <td>5,000</td> </tr> <tr> <td>PSR400</td> <td>ITQ</td> <td>Embossed tape (8mm Pitch)</td> <td>3,000</td> </tr> <tr> <td>PSR500</td> <td>HTQ</td> <td>Embossed tape (12mm Pitch)</td> <td>2,000</td> </tr> </tbody> </table>	Type	Code	Packaging specification	Quantity pcs/Reel	PSR100	ITQ ^{*1}	Embossed tape (8mm Pitch)	3,000	KTQ ^{*2}	Embossed tape (8mm pitch)	5,000	PSR330	ITQ	Embossed tape (8mm pitch)	3,000	PSR350	KTQ	Embossed tape (8mm Pitch)	5,000	PSR400	ITQ	Embossed tape (8mm Pitch)	3,000	PSR500	HTQ	Embossed tape (12mm Pitch)	2,000	<table border="1"> <thead> <tr> <th>Tolerance</th> </tr> </thead> <tbody> <tr> <td>F (±1%)</td> </tr> </tbody> </table>	Tolerance	F (±1%)	<table border="1"> <thead> <tr> <th>Special code</th> <th>Nominal resistance</th> </tr> </thead> <tbody> <tr> <td>B</td> <td>0.1mΩ</td> </tr> <tr> <td>C</td> <td>0.2mΩ</td> </tr> <tr> <td>CW^{*3}</td> <td>0.27mΩ</td> </tr> <tr> <td>D</td> <td>0.3mΩ</td> </tr> <tr> <td>E</td> <td>0.4mΩ</td> </tr> <tr> <td>F</td> <td>0.5mΩ</td> </tr> <tr> <td>H</td> <td>1.0mΩ</td> </tr> <tr> <td>J</td> <td>2.0mΩ</td> </tr> <tr> <td>L</td> <td>3.0mΩ</td> </tr> </tbody> </table>	Special code	Nominal resistance	B	0.1mΩ	C	0.2mΩ	CW ^{*3}	0.27mΩ	D	0.3mΩ	E	0.4mΩ	F	0.5mΩ	H	1.0mΩ	J	2.0mΩ	L	3.0mΩ	<table border="1"> <thead> <tr> <th>Resistance code, 4 digits</th> <th>4 digits</th> </tr> </thead> <tbody> <tr> <td>0.1mΩ</td> <td>0L10</td> </tr> <tr> <td>0.2mΩ</td> <td>0L20</td> </tr> <tr> <td>0.27mΩ</td> <td>0L27</td> </tr> <tr> <td>0.3mΩ</td> <td>0L30</td> </tr> <tr> <td>0.4mΩ</td> <td>0L40</td> </tr> <tr> <td>0.5mΩ</td> <td>0L50</td> </tr> <tr> <td>1.0mΩ</td> <td>1L00</td> </tr> <tr> <td>2.0mΩ</td> <td>2L00</td> </tr> <tr> <td>3.0mΩ</td> <td>3L00</td> </tr> </tbody> </table>	Resistance code, 4 digits	4 digits	0.1mΩ	0L10	0.2mΩ	0L20	0.27mΩ	0L27	0.3mΩ	0L30	0.4mΩ	0L40	0.5mΩ	0L50	1.0mΩ	1L00	2.0mΩ	2L00	3.0mΩ	3L00
Part No.	Size	(mm)	[inch]																																																																																														
100	(6432)	[2512]																																																																																															
330	(6464)	[2525]																																																																																															
350	(7.9×5.6)	[3222]																																																																																															
400	(10×5.2)	[3921]																																																																																															
500	(15×7.75)	[5931]																																																																																															
Type	Code	Packaging specification	Quantity pcs/Reel																																																																																														
PSR100	ITQ ^{*1}	Embossed tape (8mm Pitch)	3,000																																																																																														
	KTQ ^{*2}	Embossed tape (8mm pitch)	5,000																																																																																														
PSR330	ITQ	Embossed tape (8mm pitch)	3,000																																																																																														
PSR350	KTQ	Embossed tape (8mm Pitch)	5,000																																																																																														
PSR400	ITQ	Embossed tape (8mm Pitch)	3,000																																																																																														
PSR500	HTQ	Embossed tape (12mm Pitch)	2,000																																																																																														
Tolerance																																																																																																	
F (±1%)																																																																																																	
Special code	Nominal resistance																																																																																																
B	0.1mΩ																																																																																																
C	0.2mΩ																																																																																																
CW ^{*3}	0.27mΩ																																																																																																
D	0.3mΩ																																																																																																
E	0.4mΩ																																																																																																
F	0.5mΩ																																																																																																
H	1.0mΩ																																																																																																
J	2.0mΩ																																																																																																
L	3.0mΩ																																																																																																
Resistance code, 4 digits	4 digits																																																																																																
0.1mΩ	0L10																																																																																																
0.2mΩ	0L20																																																																																																
0.27mΩ	0L27																																																																																																
0.3mΩ	0L30																																																																																																
0.4mΩ	0L40																																																																																																
0.5mΩ	0L50																																																																																																
1.0mΩ	1L00																																																																																																
2.0mΩ	2L00																																																																																																
3.0mΩ	3L00																																																																																																

*1 : ITQ : Apply to 0.2mΩ
 *2 : KTQ : Apply to 0.3mΩ~3.0mΩ
 *3 : Only PSR350

8. Bill of Material

Table 6 shows the list of components used in the simulation schematic. Each of the capacitors has the parameters of equivalent circuit shown below. The default value of equivalent components are set to zero except for the ESR of C. You can modify the values of each component.

Table 6. List of components used in the simulation circuit

Type	Instance Name	Default Value	Variable Range		Units
			Min	Max	
Resistor	Load	1.2	free		Ω
	R1, R2	10k	free		Ω
	R3	510	free		Ω
	R4, R5	1k	free		Ω
Capacitor	C1	0.1u	free		F
	C2	22n	free		F
	C3	10n	free		F

Capacitor Equivalent Circuits

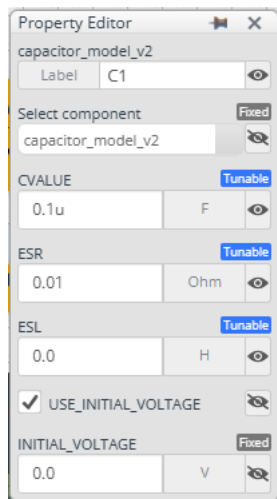

(a) Property editor

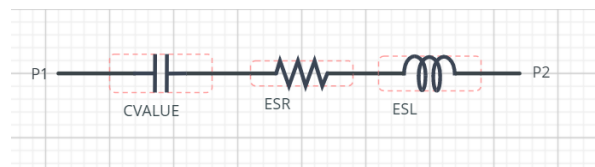

(b) Equivalent Circuits

Figure 6. Capacitor property editor and equivalent circuit

The default value of ESR of C is 0.01 Ω .

(Note) These parameters can take any positive value or zero in simulation but it does not guarantee the operation of the IC in any condition. Refer to the datasheet to determine adequate value of parameters.

9. Recommend Products and Application Notes

Current Sense Amplifier [Current Sense Amplifier ICs](#)

Shunt resistor [PSR Series](#)

MOSFET [Automotive MOSFETs](#) [12 to 150V Single-Nch MOSFETs](#)

Thermal simulation [How to Use SPICE Self-Heating Models: Coupled Electro-Thermal Analysis](#)

Notice

- 1) The information contained in this document is intended to introduce ROHM Group (hereafter referred to as ROHM) products. When using ROHM products, please verify the latest specifications or datasheets before use.
- 2) ROHM products are designed and manufactured for use in general electronic equipment and applications (such as Audio Visual equipment, Office Automation equipment, telecommunication equipment, home appliances, amusement devices, etc.) or specified in the datasheets. Therefore, please contact the ROHM sales representative before using ROHM products in equipment or devices requiring extremely high reliability and whose failure or malfunction may cause danger or injury to human life or body or other serious damage (such as medical equipment, transportation, traffic, aircraft, spacecraft, nuclear power controllers, fuel control, automotive equipment including car accessories, etc. hereafter referred to as Specific Applications). Unless otherwise agreed in writing by ROHM in advance, ROHM shall not be in any way responsible or liable for any damages, expenses, or losses incurred by you or third parties arising from the use of ROHM Products for Specific Applications.
- 3) Electronic components, including semiconductors, can fail or malfunction at a certain rate. Please be sure to implement, at your own responsibilities, adequate safety measures including but not limited to fail-safe design against physical injury, and damage to any property, which a failure or malfunction of products may cause.
- 4) The information contained in this document, including application circuit examples and their constants, is intended to explain the standard operation and usage of ROHM products, and is not intended to guarantee, either explicitly or implicitly, the operation of the product in the actual equipment it will be used. As a result, you are solely responsible for it, and you must exercise your own independent verification and judgment in the use of such information contained in this document. ROHM shall not be in any way responsible or liable for any damages, expenses, or losses incurred by you or third parties arising from the use of such information.
- 5) When exporting ROHM products or technologies described in this document to other countries, you must abide by the procedures and provisions stipulated in all applicable export laws and regulations, such as the Foreign Exchange and Foreign Trade Act and the US Export Administration Regulations, and follow the necessary procedures in accordance with these provisions.
- 6) The technical information and data described in this document, including typical application circuits, are examples only and are not intended to guarantee to be free from infringement of third parties intellectual property or other rights. ROHM does not grant any license, express or implied, to implement, use, or exploit any intellectual property or other rights owned or controlled by ROHM or any third parties with respect to the information contained herein.
- 7) No part of this document may be reprinted or reproduced in any form by any means without the prior written consent of ROHM.
- 8) All information contained in this document is current as of the date of publication and subject to change without notice. Before purchasing or using ROHM products, please confirm the latest information with the ROHM sales representative.
- 9) ROHM does not warrant that the information contained herein is error-free. ROHM shall not be in any way responsible or liable for any damages, expenses, or losses incurred by you or third parties resulting from errors contained in this document.



Thank you for your accessing to ROHM product informations.
More detail product informations and catalogs are available, please contact us.

ROHM Customer Support System

<https://www.rohm.com/contactus>