

(C-014-DOT) DC-DC LLC Full-Bridge Converter (DOT247)

Simulation Parameters

Name	Content	unit	Default Value	Variable Range	
Transformer	Np: Primary-turns	turns	18	1 ~ 1000	
	Ns: Secondary-turns	turns	1	1 ~ 1000	
	Lm: Magnetizing Inductance	H	60u	1n~1	
Rp	Transformer Resistance	Ω	5m	1m ~ 1	
Rs	Transformer Resistance	Ω	1m	1m ~ 1	
Lr	Resonant Inductance	H	12u	1n ~ 1	
Cr	Resonant Capacitance	F	100n	1n ~ 1	
Cout	Output Capacitance	F	4.7m	1n ~ 1	
	Initial Voltage	V	50	0 ~ 80	
ESR	ESR of Cout	Ω	15m	1m ~ 1	
Primary	Thcap_Primary	Thermal Capacitance	J/K	0.1	1m ~ 100
	Rth_Primary	Thermal Resistance	K/W	0.1	1m ~ 100
	TGND_Primary	Ambient Temperature	°C	25	-40 ~ 175
Secondary	Thcap_Secondary	Thermal Capacitance	J/K	0.1	1m ~ 100
	Rth_Secondary	Thermal Resistance	K/W	0.1	1m ~ 100
	TGND_Secondary	Ambient Temperature	°C	25	-40 ~ 175

Name	Content	unit	Default Value	Variable Range	
Test_time	Test time in simulation	s	0.2	10u ~ 0.5	
Vin_dc	Input Voltage	V	800	400 ~ 1,200	
Vout_dc	Output Voltage	V	50	1 ~ 1200	
Pout	Output Power	W	10k	100~30k	
fs_ref	Target Carrier Frequency	Hz	100k	10k~500k	
Primary	Rg_on 1*	Gate Resistance (Source)	Ω	4.7	0.1 ~ 100
	Rg_off 1*	Gate Resistance (Sink)	Ω	2.0	0.1 ~ 100
	DT1	Dead Time	s	100n	0 ~ 1m
Secondary	Rg_on 2*	Gate Resistance (Source)	Ω	10	0.1 ~ 100
	Rg_off 2*	Gate Resistance (Sink)	Ω	10	0.1 ~ 100
	DT2	Dead Time	s	100n	0 ~ 1m
T_init**	Initial Junction Temp.	°C	25	-40 ~ 175	

*Common for all MOSFETs in the same side.

**Common for all devices

Simulation Circuit

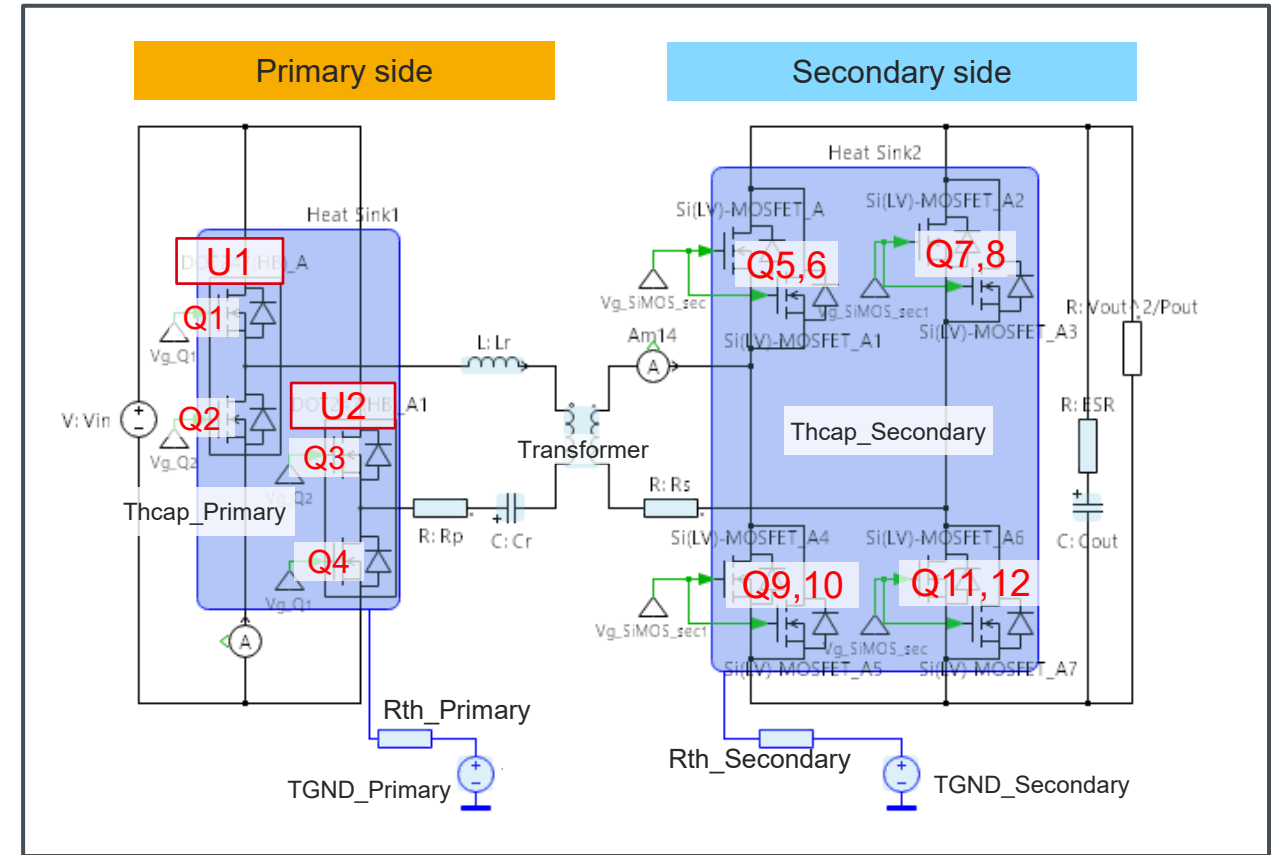

Default Devices

Name	Device Type	Part No.	Specification
U1,2	SiC MOSFET Module	SCZ4006KTA	1200V/ 209A/ 6mΩ/ DOT247
Q5~12	Si MOSFET	RS7N200BH	80V/ 200A/ 1.7mΩ/ DFN5060-8S

Schematic window

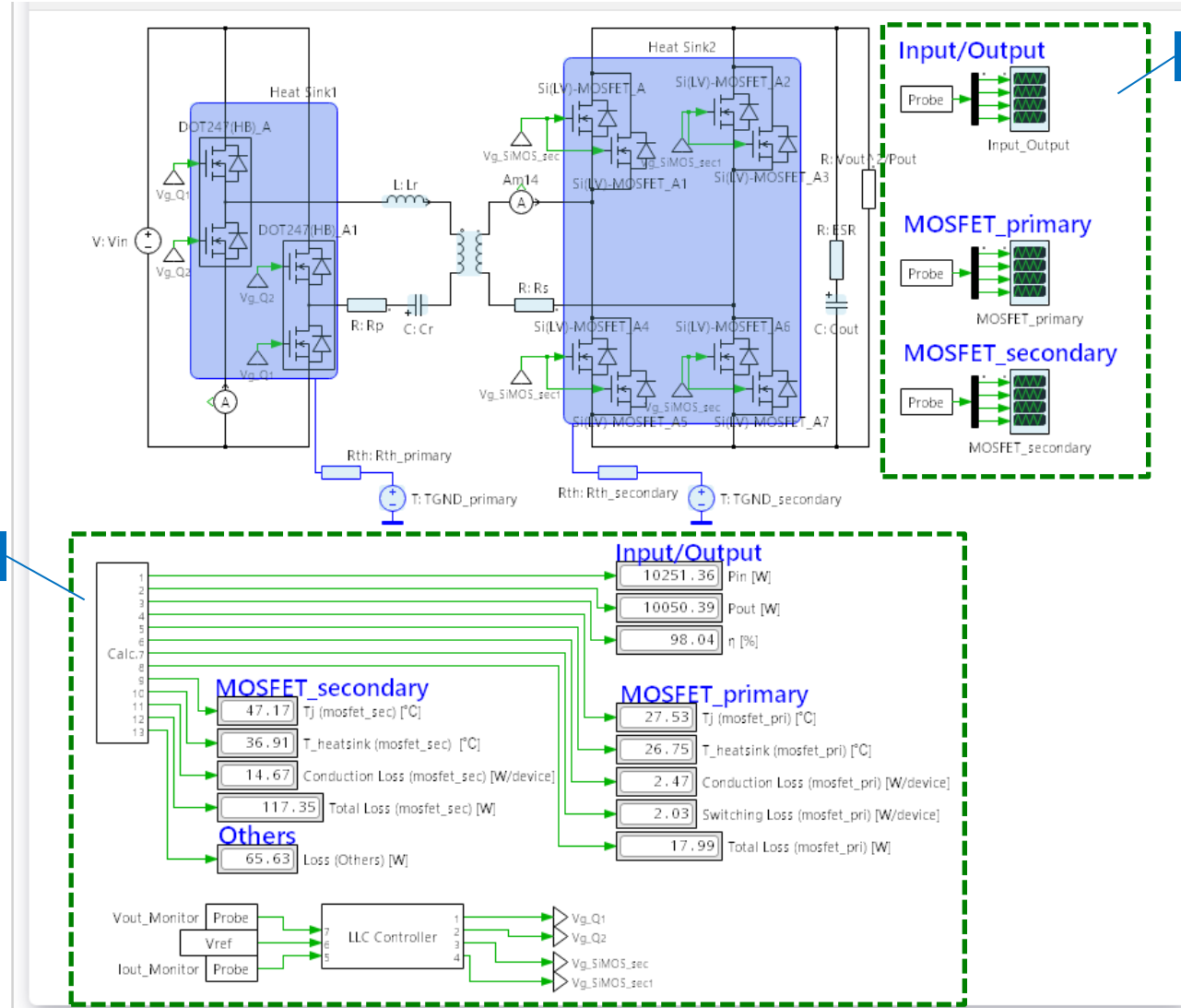

• Scope the waveform

• Results display

Simulation Results 1

Input and Output

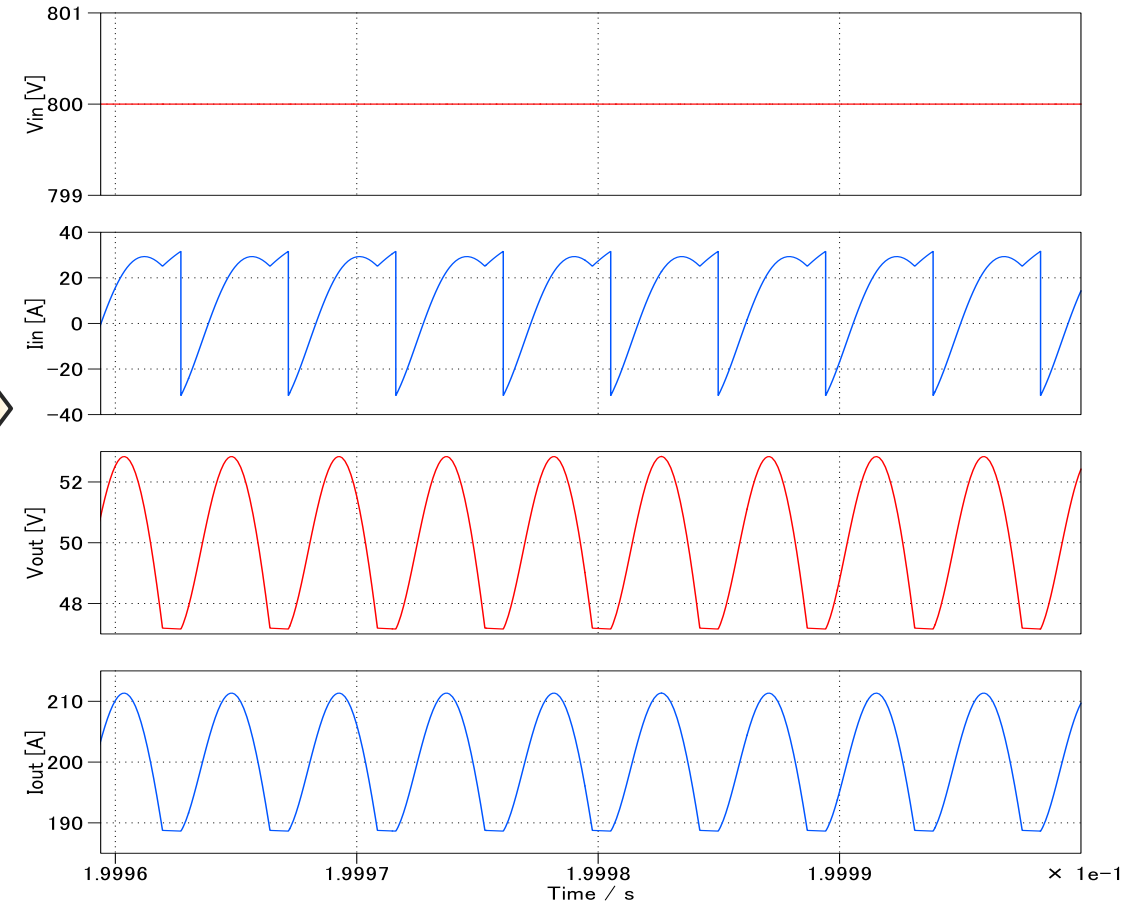
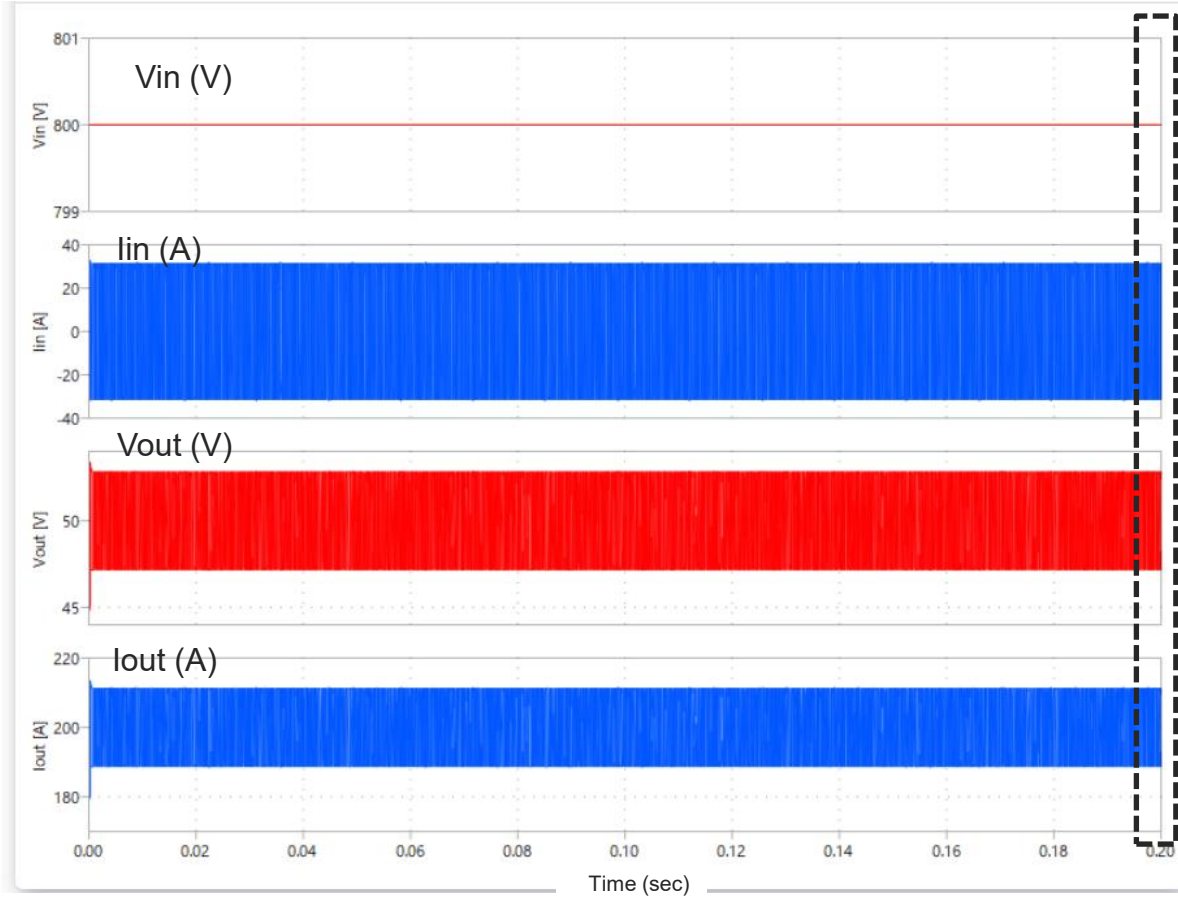

Contents	Results
Input Power : P_{in}	10.251 (kW)
Output Power: P_{out}	10.050 (kW)
Efficiency: η	98.04 (%)

Simulation Results 2

Primary side

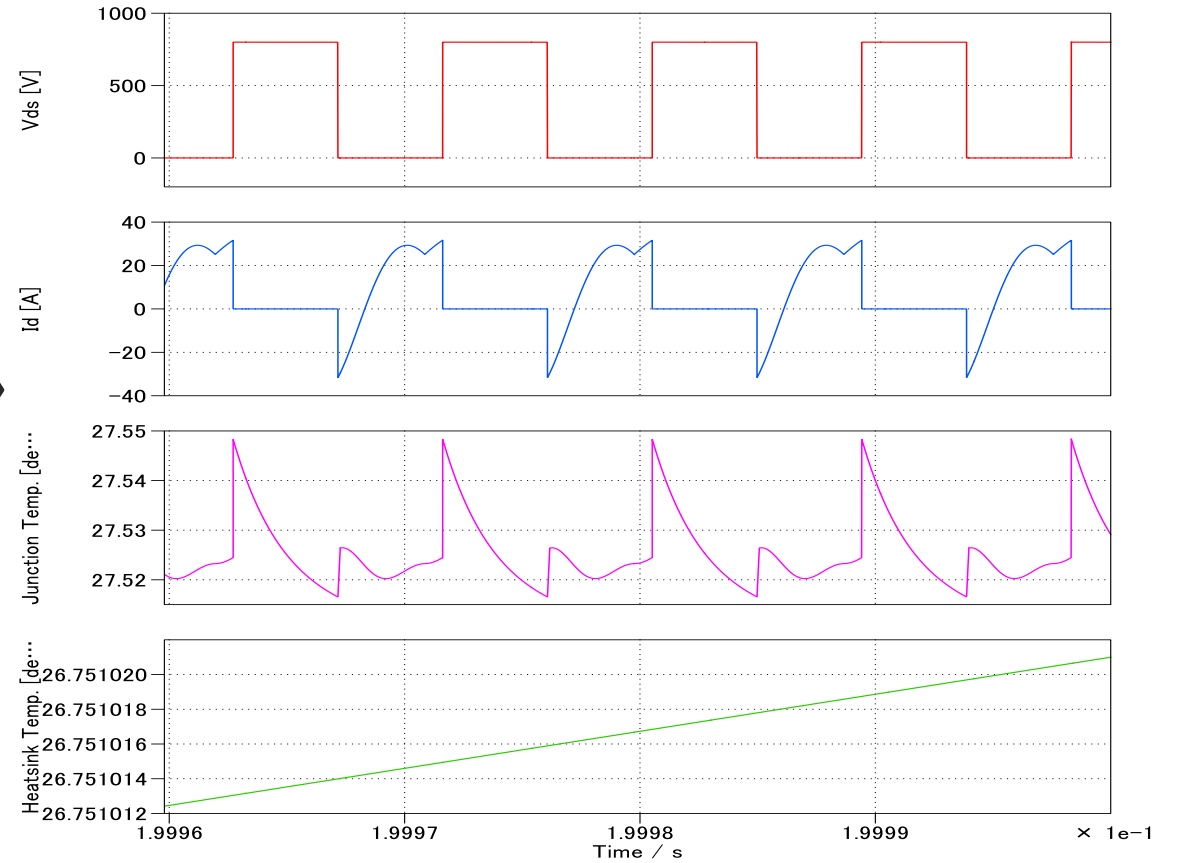
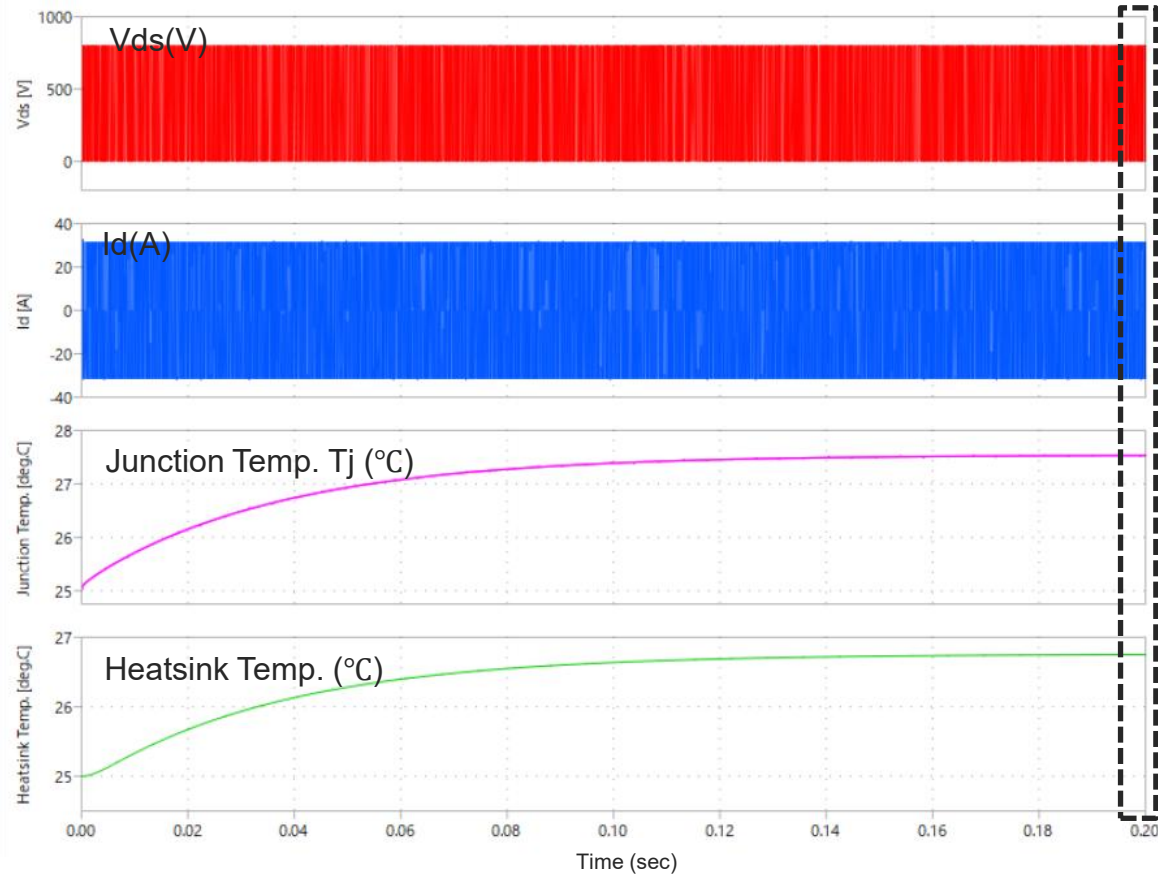

Contents	Results
Conduction Loss: P_{cond} (primary)	2.47 (W/device)
Switching Loss: P_{sw} (primary)	2.03 (W/device)
Junction Temp. : T_j (primary)	27.53 (°C)
Heatsink Temp.: T_{hs} (primary)	25.75 (°C)
Total Loss: P_{tot} (primary)	17.99 (W)

Simulation Results 3

Secondary side

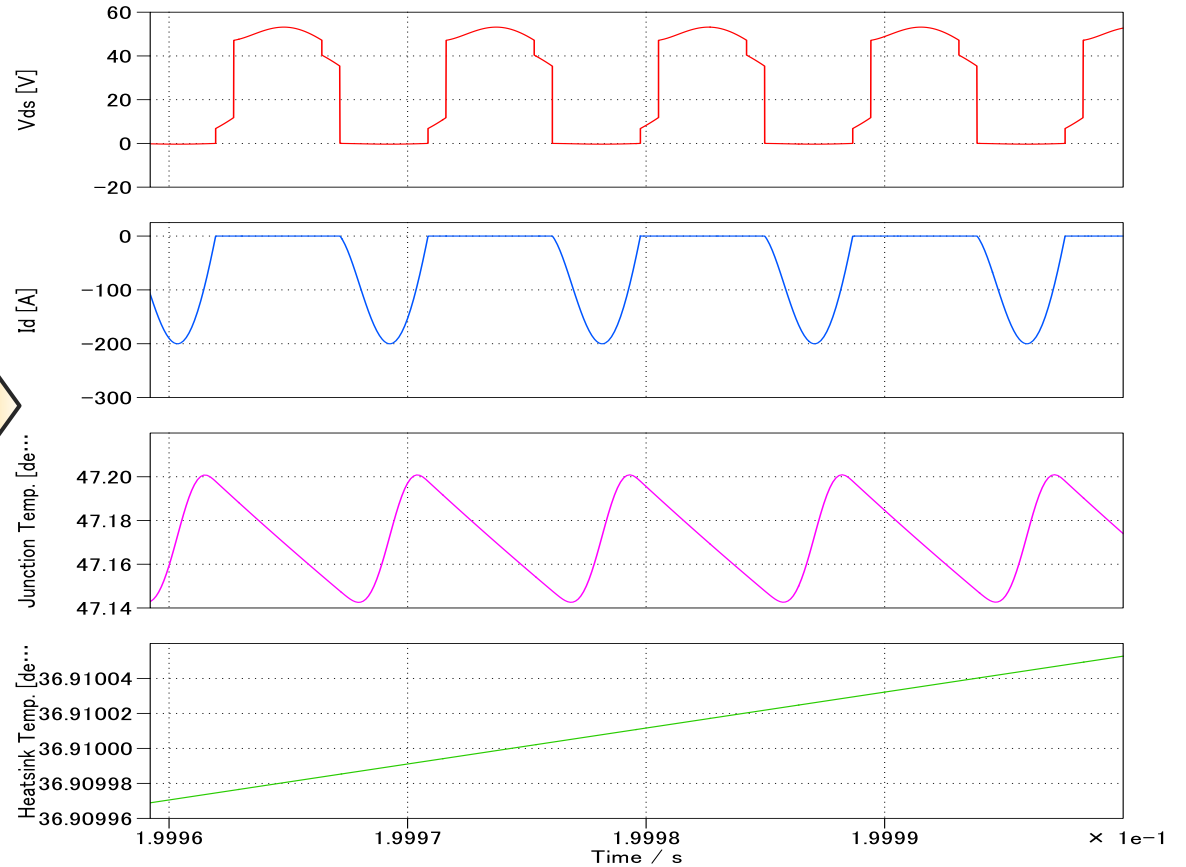
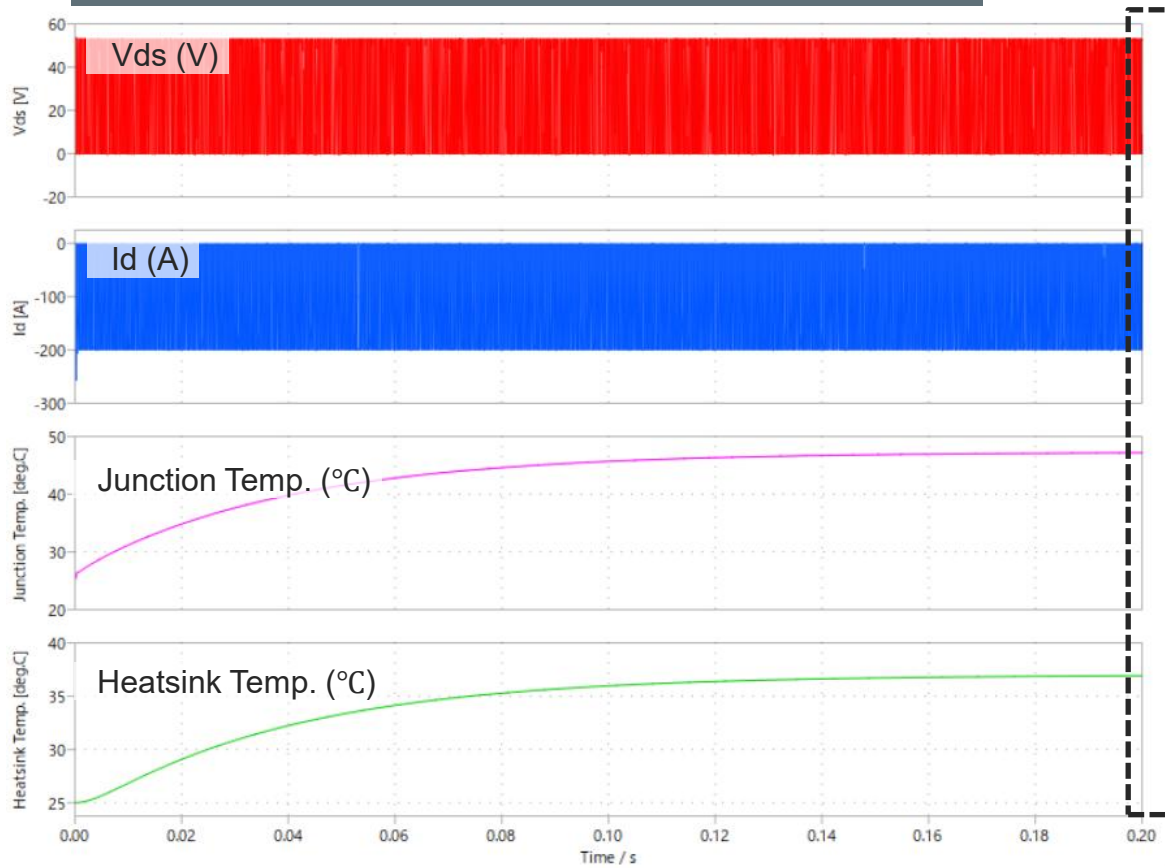

Contents	Results
Conduction Loss: Pcond (secondary)	14.67 (W/device)
Junction Temp. : Tj (secondary)	47.17 (°C)
Heatsink Temp.: T_hs (secondary)	36.91 (°C)
Total Loss: Ptot (secondary)	117.35 (W)

To run this PLECS Reference Circuit, you must have the "PLECS" simulation software installed on your computer.

1. Obtaining the Software

If you do not have PLECS installed, please download the installer from the official website and complete the setup process.

<https://www.plexim.com/download>

2. Licensing (Using Demo Mode)

This reference circuit can be executed and viewed in "Demo Mode" even if you do not possess a paid license.

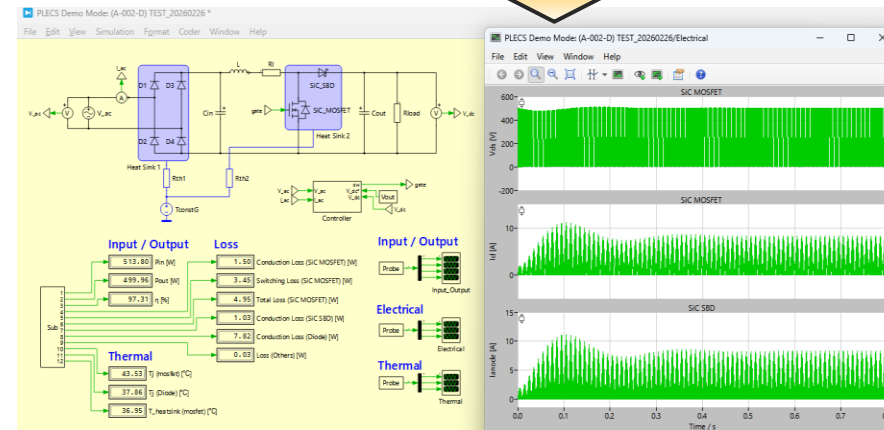
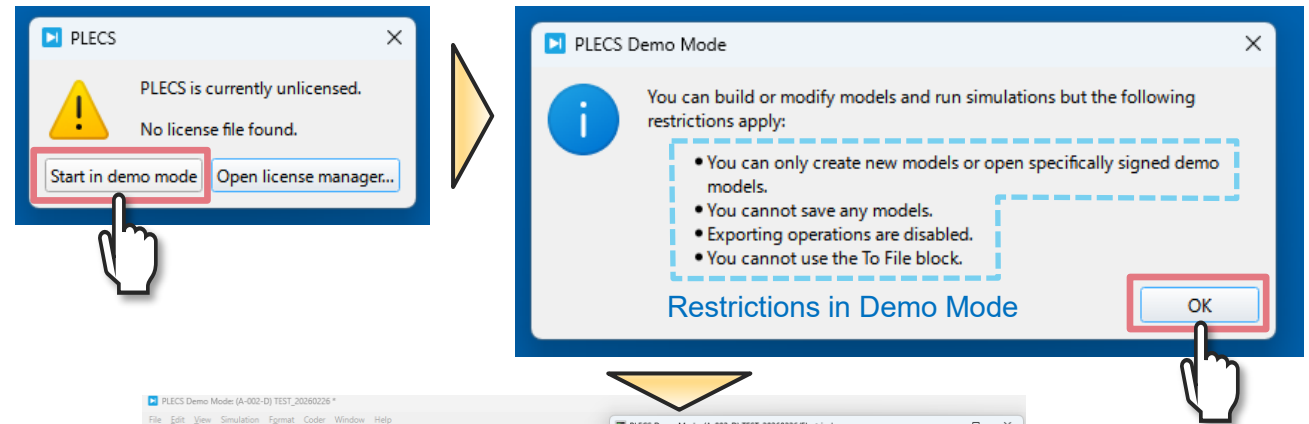

Schematic window

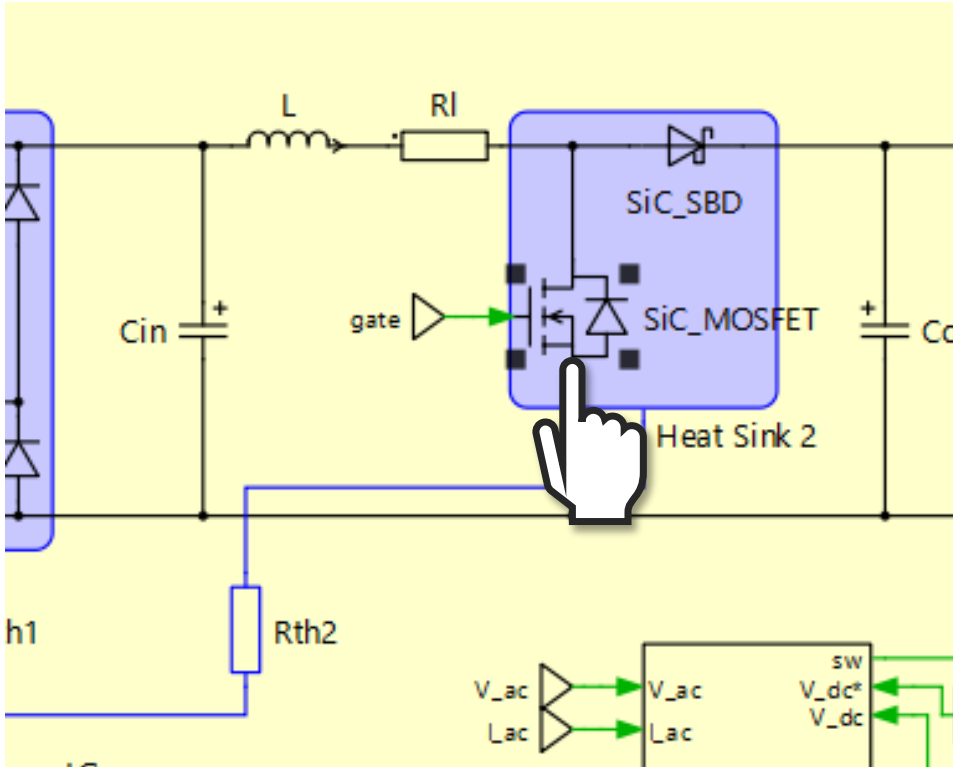

Block Parameters: (A-002-D) AC-DC Boost PFC Diode Rectific... X

SiC-MOSFET (mask)

Model Generated by ROHM
All Rights Reserved
Commercial Use or Resale Restricted

Date: 21-Jan.-2026

Parameters Assertions

SiC-MOSFET:
SiCMOS

Custom variables:
struct('Rg_on', 'Rg_on', 'Rg_off', 'Rg_off', 'sw', 'sw')

Gate resistance (on):
Rg_on

Gate resistance (off):
Rg_off

Initial temperature:
T_init

Initial Ron:
Ron_init

OK Cancel Apply Help

- From library...
- By reference
- Edit...
- Remove
- New thermal description...
- New thermal package description...

[SiC-MOSFET] TO-247-4L_750V_25A_65mΩ (SCT4065DR)
[SiC-MOSFET] TO-247-4L_750V_34A_45mΩ (SCT4045DR)
[SiC-MOSFET] TO-247-4L_750V_42A_36mΩ (SCT4036DR)
[SiC-MOSFET] TO-247-4L_750V_56A_26mΩ (SCT4026DR)
[SiC-MOSFET] TO-247N_1200V_19A_90mΩ (SCT4090KE)
[SiC-MOSFET] TO-247N_1200V_26A_62mΩ (SCT4062KE)
[SiC-MOSFET] TO-247N_1200V_32A_50mΩ (SCT4050KE)
[SiC-MOSFET] TO-247N_1200V_40A_36mΩ (SCT4036KE)
[SiC-MOSFET] TO-247N_1200V_81A_18mΩ (SCT4018KE)
[SiC-MOSFET] TO-247N_750V_105A_13mΩ (SCT4013DE)
[SiC-MOSFET] TO-247N_750V_25A_65mΩ (SCT4065DE)
[SiC-MOSFET] TO-247N_750V_34A_45mΩ (SCT4045DE)
[SiC-MOSFET] TO-247N_750V_42A_36mΩ (SCT4036DE)
[SiC-MOSFET] TO-247N_750V_56A_26mΩ (SCT4026DE)
[SiC-MOSFET] TO-263-7LA_1200V_17A_90mΩ (SCT4090KWA)
[SiC-MOSFET] TO-263-7LA_1200V_24A_62mΩ (SCT4062KWA)
[SiC-MOSFET] TO-263-7LA_1200V_29A_50mΩ (SCT4050KWA)
[SiC-MOSFET] TO-263-7LA_1200V_40A_36mΩ (SCT4036KWA)
[SiC-MOSFET] TO-263-7LA_1200V_75A_18mΩ (SCT4018KWA)
[SiC-MOSFET] TO-263-7LA_750V_22A_65mΩ (SCT4065DWA)
[SiC-MOSFET] TO-263-7LA_750V_31A_45mΩ (SCT4045DWA)
[SiC-MOSFET] TO-263-7LA_750V_38A_36mΩ (SCT4036DWA)
[SiC-MOSFET] TO-263-7LA_750V_51A_26mΩ (SCT4026DWA)
[SiC-MOSFET] TOLL_750V_120A_13mΩ (SCT4013DLL)
[SiC-MOSFET] TOLL_750V_26A_65mΩ (SCT4065DLL)
[SiC-MOSFET] TOLL_750V_37A_45mΩ (SCT4045DLL)

Hover your mouse cursor over the device symbol that you want to change and double-click the left button of the mouse.

Click "... " > "From library..." to view the list of available devices and you can select a favorite device from these.

If the model you need is not in the list, please refer to the application note "[How to Use PLECS Models](#)".

How to change the simulation parameters

Schematic window

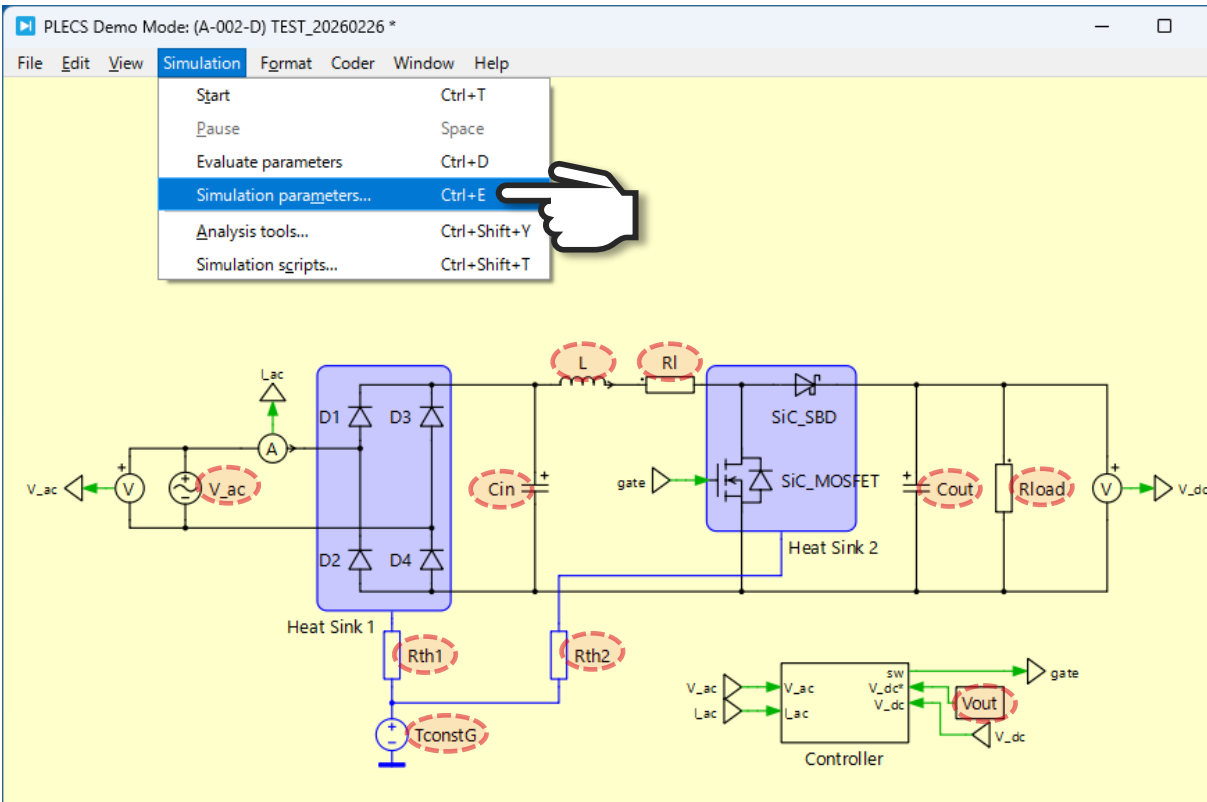

The 'Simulation Parameters' dialog box is shown with the 'Initialization' tab selected. The 'Model initialization commands' section contains the following parameterized code:

```
1 % General|
2 Test time = 0.8; % End time of simulation [s]
3 SiCMOS = 'file:SC14065DR';
4 SiCSBD = 'file:SCS320AG';
5
6 % Grid
7 Vin = 100;
8 %Wac = Vin*sqrt(2); % Grid voltage [V]
9 Vout = 500
10 F = 50.0; % Grid frequency [Hz]
11
12 % Plant
13 fs_k = 50; % Switching frequency [kHz]
14 %fs = fs_k*1e3; % Switching frequency [Hz]
15
16 Rl = 0.001
17 Rload = 500; % Load resistance [ohms]
18 Rsense = 0.0025; % Sense resistance [ohms]
19 L = 1e-3; % Choke inductance [H]
20 Cin = 0.1e-6; % Input capacitor [C]
21 Cout = 1e-3; % Output capacitor [C]
22 C1 = 470e-9; % Reference capacitor [C]
23
24 %Wcout_init = Vout; %Initial Voltage of Output Capacitor [V]
25
26
27 R_Di = 0.02; % Diode On-resistance [ohm]
28 V_F_Di = 0.6; % Diode On-resistance [ohm]
29
30 % Thermal system
31 T_init = 25; % Initial Temperature of Heatsink [deg.C]
32 Thcap_1 = 0.001; % Thermal capacitance of Heatsink [J/K]
33 Thcap_2 = 0.001; % Thermal capacitance of Heatsink [J/K]
34 Rth_1 = 2.0; % Thermal Resistance [K/W]
35 Rth_2 = 2.0; % Thermal Resistance [K/W]
36 T_GND = 25; %Thermal GND Temperature [deg.C]
37
```

All simulation parameters are parameterized. To modify them, go to the menu, select "Simulation parameters..." , and edit the values within "Model initialization commands."

Notice

- 1) The information contained in this document is intended to introduce ROHM Group (hereafter referred to as ROHM) products. When using ROHM products, please verify the latest specifications or datasheets before use.
- 2) ROHM products are designed and manufactured for use in general electronic equipment and applications (such as Audio Visual equipment, Office Automation equipment, telecommunication equipment, home appliances, amusement devices, etc.) or specified in the datasheets. Therefore, please contact the ROHM sales representative before using ROHM products in equipment or devices requiring extremely high reliability and whose failure or malfunction may cause danger or injury to human life or body or other serious damage (such as medical equipment, transportation, traffic, aircraft, spacecraft, nuclear power controllers, fuel control, automotive equipment including car accessories, etc. hereafter referred to as Specific Applications). Unless otherwise agreed in writing by ROHM in advance, ROHM shall not be in any way responsible or liable for any damages, expenses, or losses incurred by you or third parties arising from the use of ROHM Products for Specific Applications.
- 3) Electronic components, including semiconductors, can fail or malfunction at a certain rate. Please be sure to implement, at your own responsibilities, adequate safety measures including but not limited to fail-safe design against physical injury, and damage to any property, which a failure or malfunction of products may cause.
- 4) The information contained in this document, including application circuit examples and their constants, is intended to explain the standard operation and usage of ROHM products, and is not intended to guarantee, either explicitly or implicitly, the operation of the product in the actual equipment it will be used. As a result, you are solely responsible for it, and you must exercise your own independent verification and judgment in the use of such information contained in this document. ROHM shall not be in any way responsible or liable for any damages, expenses, or losses incurred by you or third parties arising from the use of such information.
- 5) When exporting ROHM products or technologies described in this document to other countries, you must abide by the procedures and provisions stipulated in all applicable export laws and regulations, such as the Foreign Exchange and Foreign Trade Act and the US Export Administration Regulations, and follow the necessary procedures in accordance with these provisions.
- 6) The technical information and data described in this document, including typical application circuits, are examples only and are not intended to guarantee to be free from infringement of third parties intellectual property or other rights. ROHM does not grant any license, express or implied, to implement, use, or exploit any intellectual property or other rights owned or controlled by ROHM or any third parties with respect to the information contained herein.
- 7) No part of this document may be reprinted or reproduced in any form by any means without the prior written consent of ROHM.
- 8) All information contained in this document is current as of the date of publication and subject to change without notice. Before purchasing or using ROHM products, please confirm the latest information with the ROHM sales representative.
- 9) ROHM does not warrant that the information contained herein is error-free. ROHM shall not be in any way responsible or liable for any damages, expenses, or losses incurred by you or third parties resulting from errors contained in this document.



Thank you for your accessing to ROHM product informations.
More detail product informations and catalogs are available, please contact us.

ROHM Customer Support System

<https://www.rohm.com/contactus>