

Product	Digital Transistor	Package	SOT-416 (EMT3)
---------	--------------------	---------	----------------

1. TEST RESULT

TEST DESCRIPTION	TEST CONDITION	STANDARD	n [pcs]	Pn [pcs]
Soldering Heat Resistance	(1) 260±5°C , 10sec. , Reflow Soldering , 2 times	JESD22-A111	22	0
	(2) 260±5°C , 10sec. , Solder-Bath		22	0
	(3) 350±10°C , 3sec. , Hand Soldering		22	0
Solderability	(1) 245±5°C , 3sec. , Reflow Soldering	J-STD-002	22	0
	(2) 245±5°C , 3sec. , Solder-Bath	JESD22-B102	22	0
Thermal Shock	0°C ~ 100°C , 100cycles	-	22	0
Temperature Cycle	-55±5°C←→150±5°C , 200cycles	JESD22-A104	22	0
High Temp. High Humidity Reverse Bias	85±2°C , 85±5%RH, Specified Bias , 1000hours	JESD22-A101	22	0
Pressure Cooker Test	121±2°C , 100%RH , 203kPa , 100hours	JESD22-A102	22	0
Load Life	25°C , Pc=Pc max. , 1000hours	-	22	0
High Temperature Reverse Bias	Ta=Tstg max. , Specified Bias , 1000hours	JESD22-A108	22	0
High Temperature Storage	Tstg max. , 1000hours	-	22	0
Low Temperature Storage	Tstg min. , 1000hours	-	22	0
Lead strength (lead pull)	Sample body fixed, pulling lead axis direction, 1N , 10±1sec.	JEITA ED-4701/400 Test Method 401	22	0

2. CRITERIA

ITEM	CONDITION	CRITERIA	
Cutoff Current : I_{CBO}	Per specification	Within two times of the standard value.	
Cutoff Current : I_{EBO}	Per specification	Within two times of the standard value.	
DC Current Gain : hFE	Per specification	Changing rate of ±20%	
Physical	Visual check	No outstanding change in physical.	
Solderability	Visual check	Reflow Soldering	Immersed surface, other than the end of pin as cut-surface, must be covered by solder.
		Solder-Bath	More than 95% of the electrode must be covered with solder.

3. JUDGEMENT

No failure is observed from each test item.

4. TEST DESCRIPTION

TEST DESCRIPTION	TEST CONDITION	CRITERIA
1. Soldering Heat Resistance *4	(1) 1) Reflow Soldering, 260±5°C(peak) , 10 sec. , 2 times 2) After reflow soldering, leave at room temp. for more than 2h.	• Shall be no mechanical damage. • See (*1) for criteria on electrical characteristics.
	(2) *3 1) Dip the whole body once into solder bath. 260±5°C, 10±1sec Solder : Sn-3Ag-0.5Cu (Lead free) 2) After dipping, leave at room temp. for more than 2h.	• Shall be no mechanical damage. • See (*1) for criteria on electrical characteristics.
	(3) 1) Hand Soldering, 350±10°C , 3sec. 2) After testing, leave at room temp. for more than 2h.	• Shall be no mechanical damage. • See (*1) for criteria on electrical characteristics.
2. Solderability *5	(1) 1) Reflow Soldering, 245±5°C(peak) , 3sec. Solder : Sn-3Ag-0.5Cu (Lead free)	• Immersed surface, other than the end of pin as cut-surface, must be covered by solder.
	(2) *3 While body to be immersed, for 10 sec., then into solder bath of 245±5°C. Thereafter leave for natural dry at room temp. then wash off flux in 2-propanol. Solder : Sn-3Ag-0.5Cu (lead free) Flux : 2-propanol (IPA) (rosin 25wt%)	At least 95% of immersed surface, other than the end of pin as cut-surface, of must be covered by solder, which is observed through 10~20X magnifying glass.
3. Thermal Shock *6	1) Temp. & Time (Change within 10 sec.) 95~100°C (Liquid) , 5min ↔ 0~5°C (Liquid) , 5min 2) Freq. 100cycles. After completion of test, leave at room temp. for more than 2h.	See (*1) for criteria on electrical characteristics.
4. Temperature Cycle *6	1) Temp. & Time (Change within 5 sec.) 55°C (air) , 30min ↔ 150°C (air) , 30min 2) Freq. 200cycles. After completion of test, leave at room temp. for more than 2h.	See (*1) for criteria on electrical characteristics.
5. High Temp. High Humidity Reverse Bias *6	1) Ta=85±3°C, RH=75~90%、Time : 1000h 2) See (*2) for the THB bias. 3) After completion of test, leave at room temp. for more than 2h.	See (*1) for criteria on electrical characteristics.
6. Pressure Cooker Test *6	1) Ta=121°C, 100%RH, P=203KPa [2atm] 2) Time : 100h 3) After completion of test, leave at room temp. for more than 2h.	See (*1) for criteria on electrical characteristics.
7. Load Life *6	1) Ta=25±5°C, P _C /P _C (max), Time : 1000h 2) See (*2) for the THB bias. 3) After completion of test, leave at room temp. for more than 2h.	See (*1) for criteria on electrical characteristics.
8. High Temperature Reverse Bias *6	1) Ta=Tstg(max)±2°C, Time : 1000h 2) See (*2) for the THB bias. 3) After completion of test, leave at room temp. for more than 2h.	See (*1) for criteria on electrical characteristics.
9. High Temperature Storage	1) Ta=Tstg(max), Time : 1000h 2) After completion of test, leave at room temp. for more than 2h.	See (*1) for criteria on electrical characteristics.
10. Low Temperature Storage	1) Ta=Tstg(min), Time : 1000h 2) After completion of test, leave at room temp. for more than 2h.	See (*1) for criteria on electrical characteristics.
11. Lead Strength (Lead Pull)	The sample body is fixed, and keep pulling the lead in lead axis direction with specified load for 10±1s.	Shall be no mechanical damage, detachment, extension between the lead and the package body.

* REMARK

*1 Criteria for electrical characteristics.

Digital Transistors
<ul style="list-style-type: none"> • $I_{CBO} > \text{Standard} \times 2$ • $I_{EBO} > \text{Standard} \times 2$ • $\frac{\Delta hFE}{hFE} > \pm 20\%$ (Darlington Transistor : $\pm 40\%$)

*2 Bias Circuit

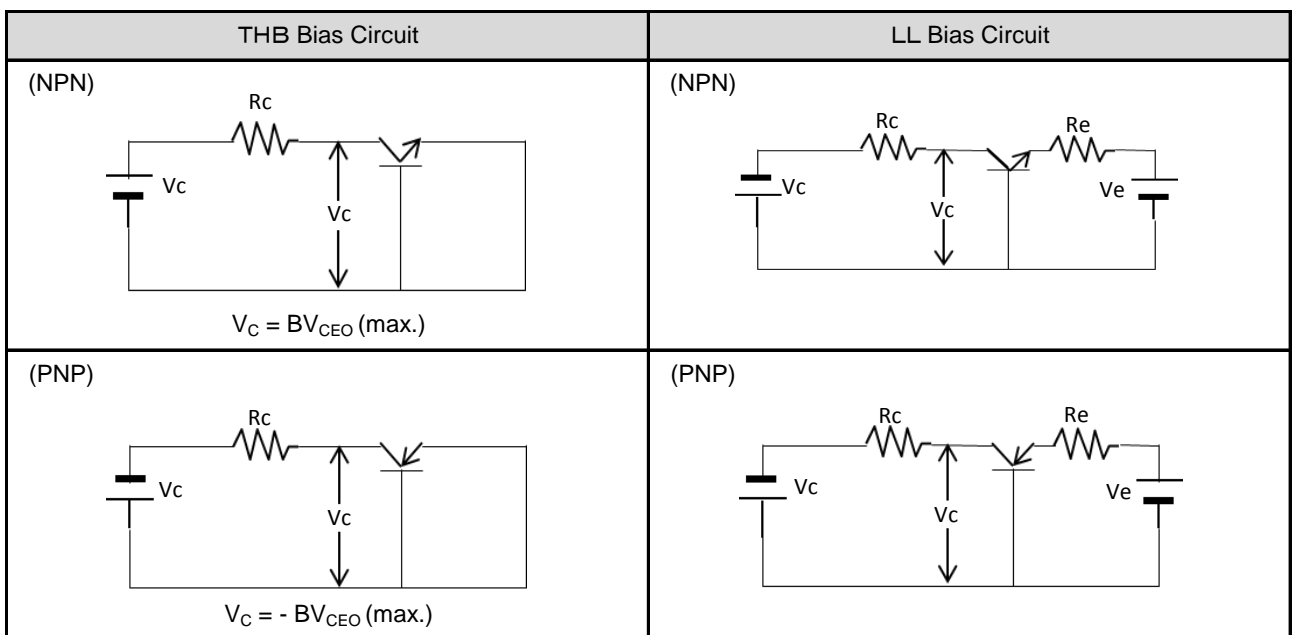

*3 Method of test 1, test 2

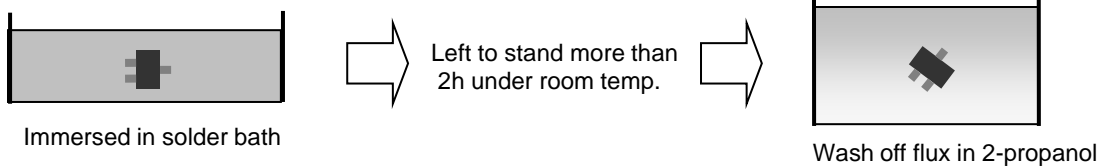

*4 Preconditioning : The test is carried out after it is left under the high temperature and the high humidity.(85°C,85%,168h)

*5 Preconditioning : Aging is done with the PCT device. (105°C,100%,1.22x10⁵Pa,4h)

*6 Preconditioning : Soldering heat resistance(260°C,10s) is carried out. (Reflow Soldering)

Notes

- 1) The information contained herein is subject to change without notice.
- 2) Before you use our Products, please contact our sales representative and verify the latest specifications :
- 3) Although ROHM is continuously working to improve product reliability and quality, semiconductors can break down and malfunction due to various factors.
Therefore, in order to prevent personal injury or fire arising from failure, please take safety measures such as complying with the derating characteristics, implementing redundant and fire prevention designs, and utilizing backups and fail-safe procedures. ROHM shall have no responsibility for any damages arising out of the use of our Products beyond the rating specified by ROHM.
- 4) Examples of application circuits, circuit constants and any other information contained herein are provided only to illustrate the standard usage and operations of the Products. The peripheral conditions must be taken into account when designing circuits for mass production.
- 5) The technical information specified herein is intended only to show the typical functions of and examples of application circuits for the Products. ROHM does not grant you, explicitly or implicitly, any license to use or exercise intellectual property or other rights held by ROHM or any other parties. ROHM shall have no responsibility whatsoever for any dispute arising out of the use of such technical information.
- 6) The Products are intended for use in general electronic equipment (i.e. AV/OA devices, communication, consumer systems, gaming/entertainment sets) as well as the applications indicated in this document.
- 7) The Products specified in this document are not designed to be radiation tolerant.
- 8) For use of our Products in applications requiring a high degree of reliability (as exemplified below), please contact and consult with a ROHM representative : transportation equipment (i.e. cars, ships, trains), primary communication equipment, traffic lights, fire/crime prevention, safety equipment, medical systems, servers, solar cells, and power transmission systems.
- 9) Do not use our Products in applications requiring extremely high reliability, such as aerospace equipment, nuclear power control systems, and submarine repeaters.
- 10) ROHM shall have no responsibility for any damages or injury arising from non-compliance with the recommended usage conditions and specifications contained herein.
- 11) ROHM has used reasonable care to ensure the accuracy of the information contained in this document. However, ROHM does not warrant that such information is error-free, and ROHM shall have no responsibility for any damages arising from any inaccuracy or misprint of such information.
- 12) Please use the Products in accordance with any applicable environmental laws and regulations, such as the RoHS Directive. For more details, including RoHS compatibility, please contact a ROHM sales office. ROHM shall have no responsibility for any damages or losses resulting from non-compliance with any applicable laws or regulations.
- 13) When providing our Products and technologies contained in this document to other countries, you must abide by the procedures and provisions stipulated in all applicable export laws and regulations, including without limitation the US Export Administration Regulations and the Foreign Exchange and Foreign Trade Act.
- 14) This document, in part or in whole, may not be reprinted or reproduced without prior consent of ROHM.



Thank you for your accessing to ROHM product informations.
More detail product informations and catalogs are available, please contact us.

ROHM Customer Support System

<http://www.rohm.com/contact/>