

熱設計

HTSOP-J8 パッケージ熱抵抗情報 (A)

対象外品番：BD4xxM2EFJ-C シリーズ、BD4xxM2WEFJ-C シリーズ、BD4xxU2EFJ-C シリーズ、BD4xxU2WEFJ-C シリーズ、BD7xxL2EFJ-C シリーズ、BD7xxU2EFJ-C シリーズ、BD42530EFJ-C、BD42530UEFJ-C、BD820F50EFJ-C、BD820F50UEFJ-C

このアプリケーションノートは HTSOP-J8 パッケージを使用して熱設計を行うために必要な、熱抵抗の情報を記載しています。設計初期の温度見積もりを行うときの参考値としてご使用ください。

目次

1. パッケージ概要	2
2. JEDEC STANDARD に準拠した環境での熱抵抗および熱特性パラメータ	2
2-1. 測定環境	2
2-2. 数値	2
2-3. PCB 仕様 1 層 (1s)	3
2-4. PCB 仕様 4 層 (2s2p)	4
3. 各パラメータを変化したときの熱抵抗および熱特性パラメータ	5
3-1. 銅箔面積を変化	5
3-1-1. 1 層	5
3-1-2. 2 層	6
3-1-3. 4 層、複数層で銅箔面積を変化した場合	7
3-1-4. 4 層、Bottom layer のみ銅箔面積を変化した場合	8
3-1-5. 6 層、複数層で銅箔面積を変化した場合	9
3-1-6. 6 層、Bottom layer のみ銅箔面積を変化した場合	10
3-1-7. 8 層、複数層で銅箔面積を変化した場合	11
3-1-8. 8 層、Bottom layer のみ銅箔面積を変化した場合	12
3-2. 銅箔厚を変化	13
3-2-1. 1 層	13
3-2-2. 2 層	14
3-2-3. 4 層	15
3-3. サーマルビア配置	16
3-3-1. 2 層	16
3-3-2. 4 層	17
3-4. 基板厚を変化	18
3-4-1. 1 層	18
3-4-2. 2 層	19
3-4-3. 4 層	20
4. 過渡熱抵抗	21
4-1. 過渡熱抵抗 1 層	21
4-2. 過渡熱抵抗 2 層	24
4-3. 過渡熱抵抗 4 層	25

1. パッケージ概要

パッケージ名 : HTSOP-J8

パッケージグループ : SOP

外形寸法 : W (typ) D (typ) H (max)
4.9mm × 6.0mm × 1.0mm

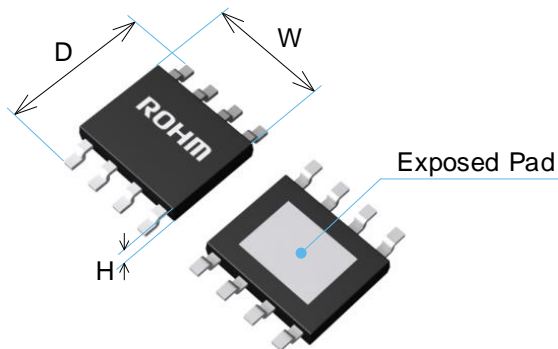

2. JEDEC STANDARD に準拠した環境での熱抵抗および熱特性パラメータ

2-1. 測定環境

内容	規格
測定環境	JEDEC STANDARD JESD51-2A (Still Air)
測定基板規格	JEDEC STANDARD JESD51-3 JESD51-5 JESD51-7

2-2. 数値

状態	θ_{JA} (°C/W)	Ψ_{JT} (°C/W)
1層 (1s)	139.0	17
4層 (2s2p)	35.6	7

θ_{JA} : ジャンクション T_J と 周囲温度 T_A 間の熱抵抗

Ψ_{JT} : ジャンクション T_J と パッケージ上面中央温度 T_T 間の熱特性パラメータ

注意 : 本アプリケーションノートでの熱抵抗および熱特性パラメータは、JEDEC STANDARD に準拠した測定環境での値であるため、必ずしも実機器と一致するものではありません。PCB 特性、PCB レイアウト、部品配置、筐体形状、周囲環境などの影響で値が変化することを考慮する必要があります。

2-3. PCB 仕様 1層 (1s)

JEDEC 規格 JESD51 準拠

項目	値	
基板厚み	1.57mm	
基板外形寸法	76.2mm × 114.3mm	
基板材質	FR-4	
トレース厚 (仕上がり厚)	Top	70 μ m (2 oz)
引き出し線幅	0.254mm	
銅箔範囲	Top	15.7mm ² (Footprint)

Table 2-3-1. 1層 PCB 仕様



Figure 2-3-1. 1層基板断面図

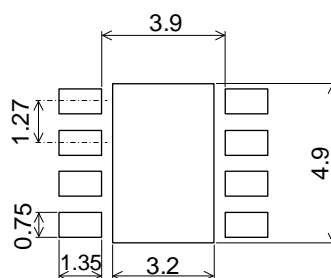

Figure 2-3-2. Footprint 寸法

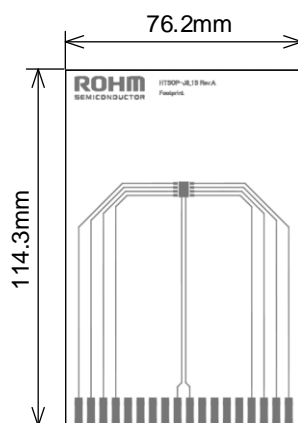

Figure 2-3-3. Top layer

2-4. PCB 仕様 4層 (2s2p)

JEDEC 規格 JESD51 準拠

項目		値
基板厚み		1.60mm
基板外形寸法		76.2mm × 114.3mm
基板材質		FR-4
トレース厚 (仕上がり厚)	Top	70μm (2 oz)
	Middle 1	35μm (1 oz)
	Middle 2	35μm (1 oz)
	Bottom	70μm (2 oz)
引き出し線幅		0.254mm
銅箔範囲	Top	15.7mm ² (Footprint)
	Middle 1	5505mm ² (74.2mm×74.2mm)
	Middle 2	5505mm ² (74.2mm×74.2mm)
	Bottom	5505mm ² (74.2mm×74.2mm)

Table 2-4-1. 4層 PCB 仕様

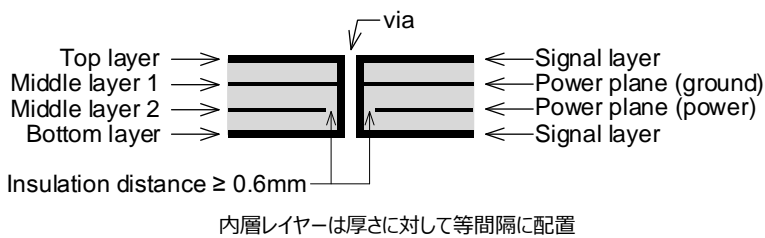

Figure 2-4-2. 4層基板断面図

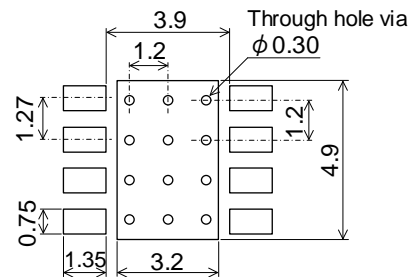

Figure 2-4-3. Footprint 寸法

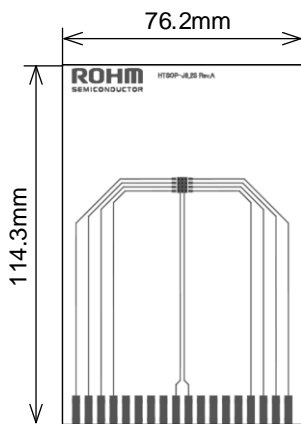

Figure 2-4-4.
Top layer

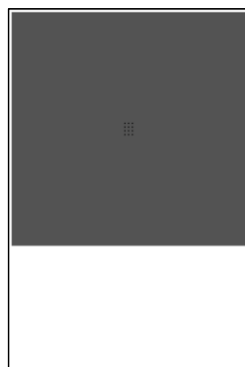

Figure 2-4-5.
Middle 1 layer

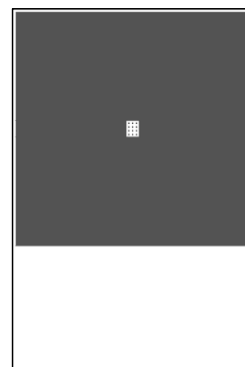

Figure 2-4-6.
Middle 2 layer

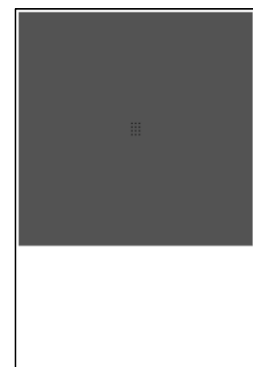

Figure 2-4-7.
Bottom layer

3. 各パラメータを変化したときの熱抵抗および熱特性パラメータ

3-1. 銅箔面積を変化

3-1-1. 1層

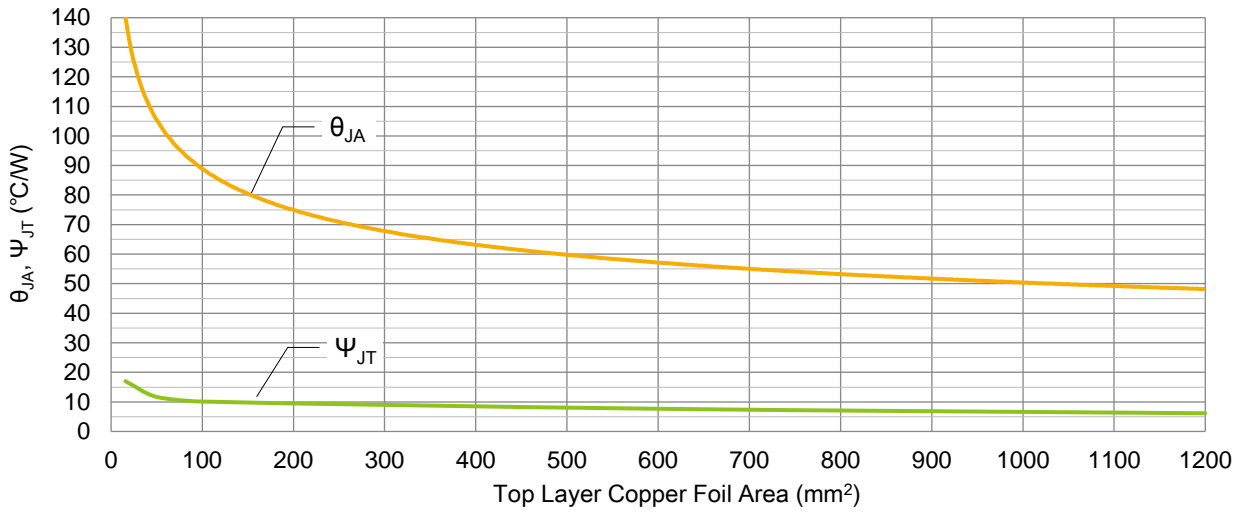

Figure 3-1-1-1. θ_{JA} , ψ_{JT} vs 銅箔面積



Figure 3-1-1-2. 1層基板断面図

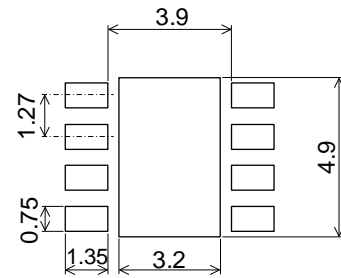

Figure 3-1-1-3. Footprint 寸法

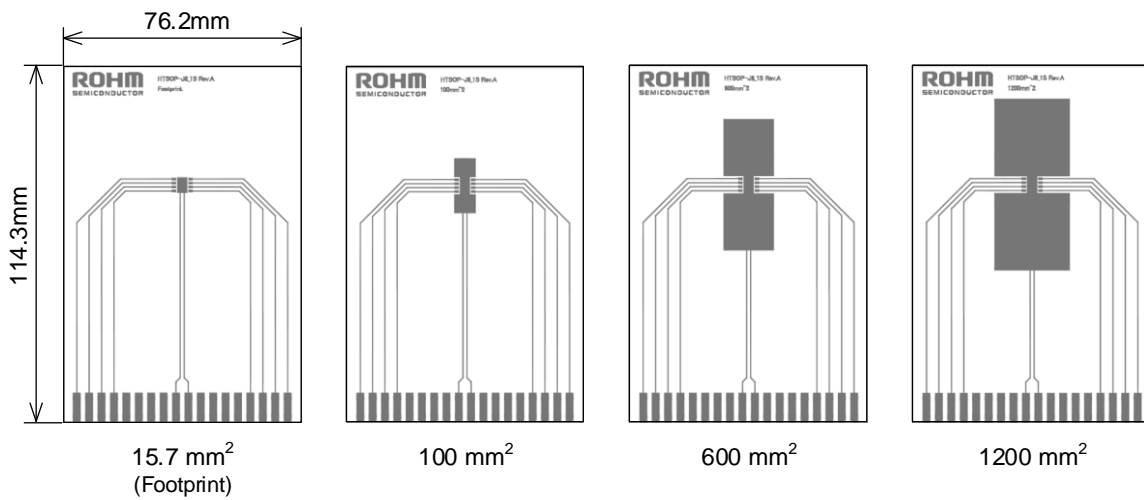

Figure 3-1-1-4. Top layer

3-1. 銅箔面積を変化 (つづき)

3-1-2. 2層

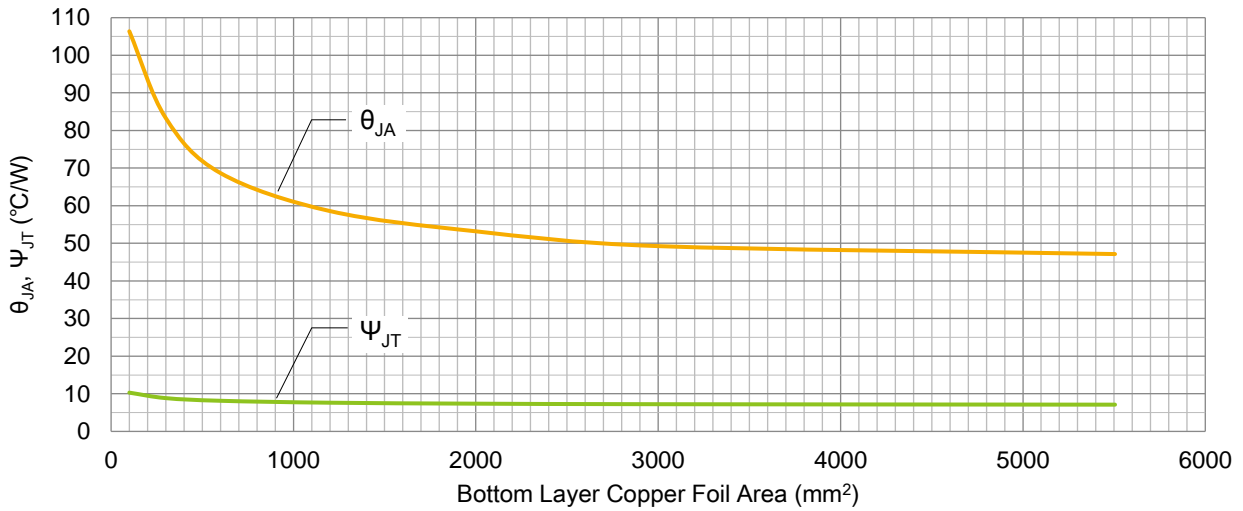

Figure 3-1-2-1. θ_{JA} , ψ_{JT} vs 銅箔面積

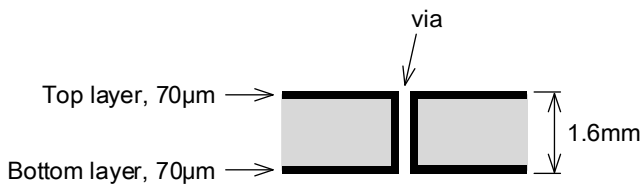

Figure 3-1-2-2. 2層基板断面図

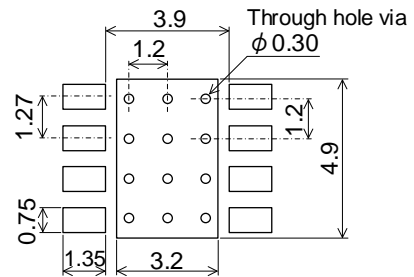

Figure 3-1-2-3. Footprint 寸法

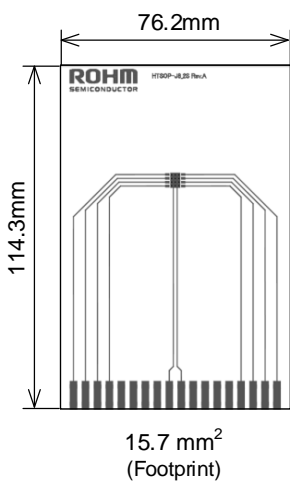

Figure 3-1-2-4. Top layer

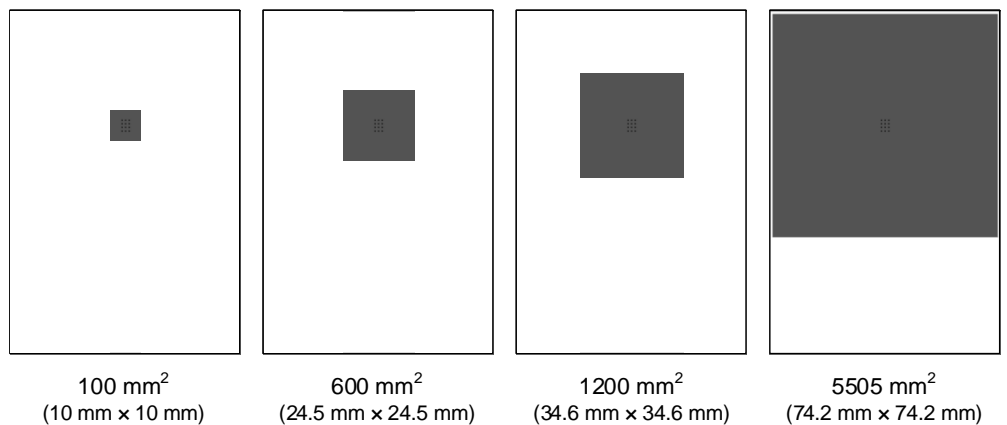

Figure 3-1-2-5. Bottom layer

3-1. 銅箔面積を変化 (つづき)

3-1-3. 4層、複数層で銅箔面積を変化した場合

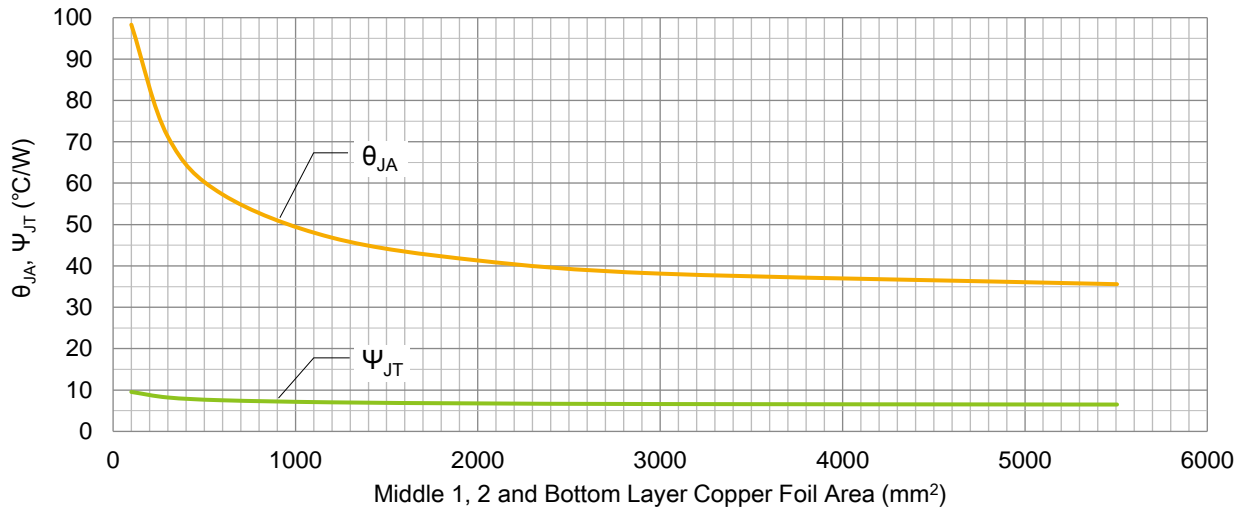

Figure 3-1-3-1. θ_{JA} , ψ_{JT} vs 銅箔面積

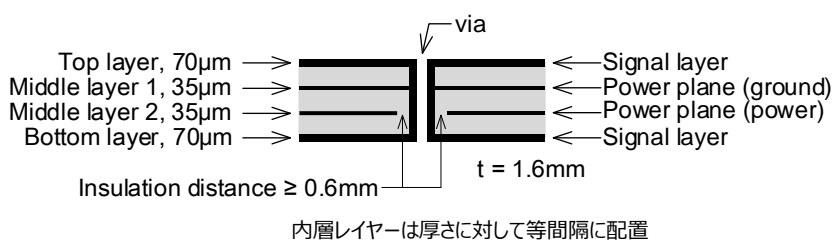

Figure 3-1-3-2. 4層基板断面図

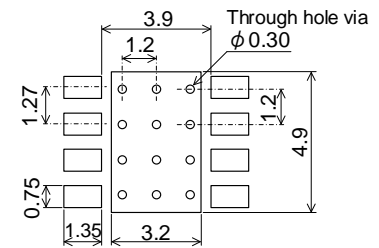

Figure 3-1-3-3. Footprint 寸法

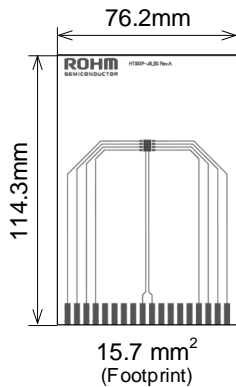

Figure 3-1-3-4. Top layer

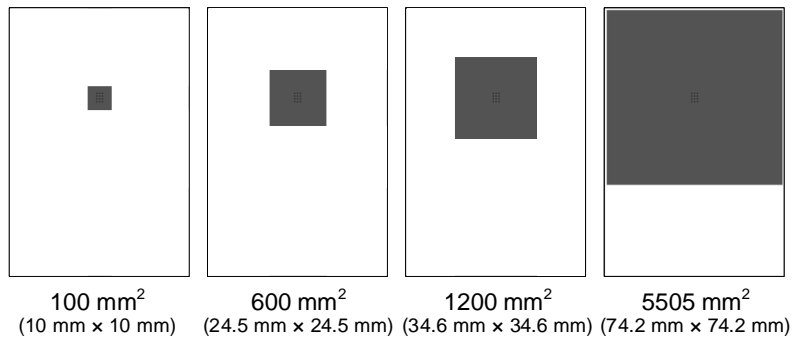

Figure 3-1-3-5. Middle layer 1, Bottom layer

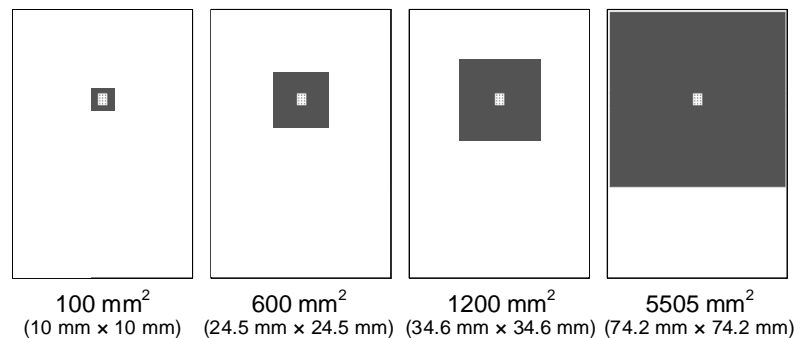

Figure 3-1-3-6. Middle layer 2

3-1. 銅箔面積を変化 (つづき)

3-1-4. 4層、Bottom layerのみ銅箔面積を変化した場合

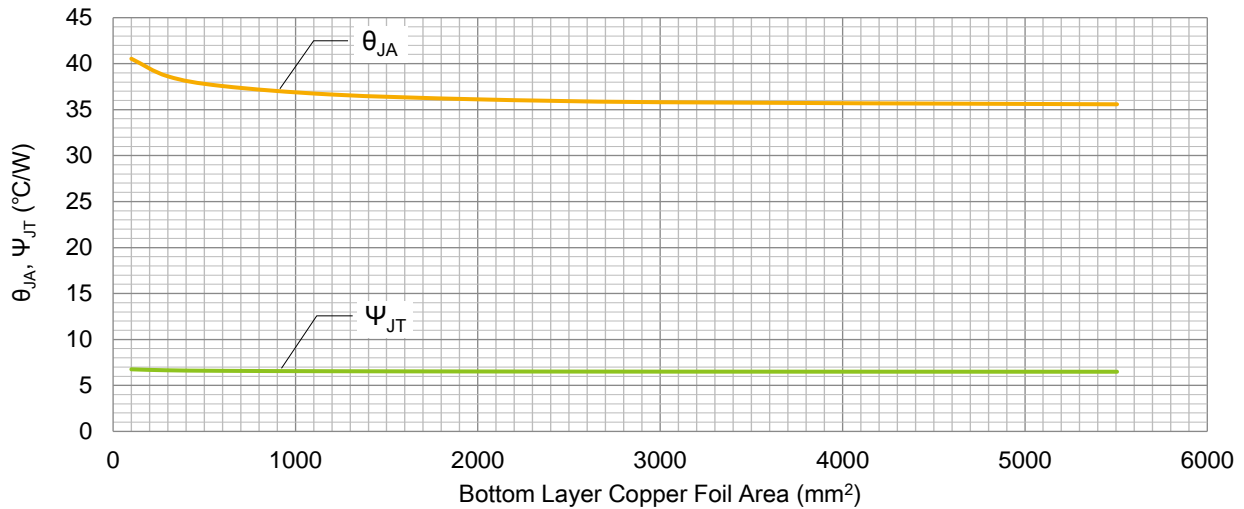

Figure 3-1-4-1. θ_{JA} , ψ_{JT} vs 銅箔面積

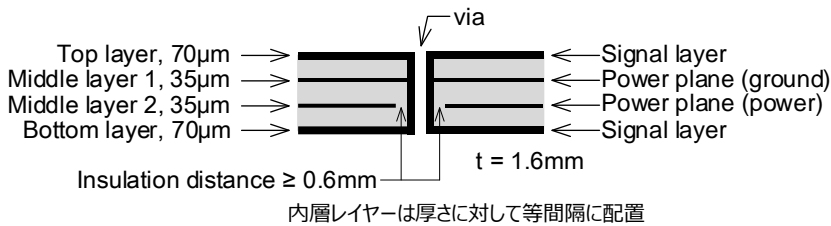

Figure 3-1-4-2. 4層基板断面図

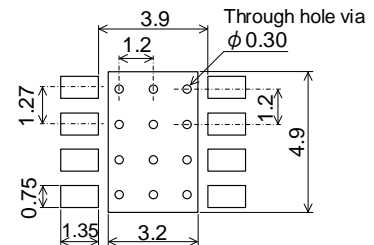

Figure 3-1-4-3. Footprint 寸法

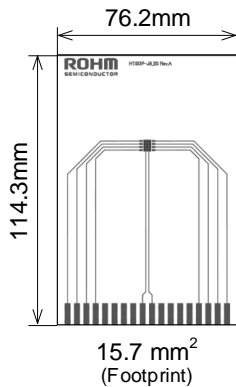

Figure 3-1-4-4. Top layer

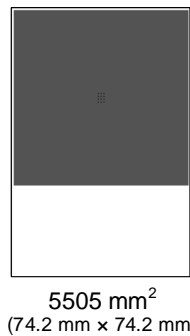

Figure 3-1-4-5. Middle layer 1

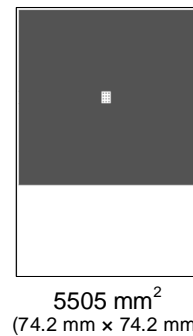

Figure 3-1-4-6. Middle layer 2

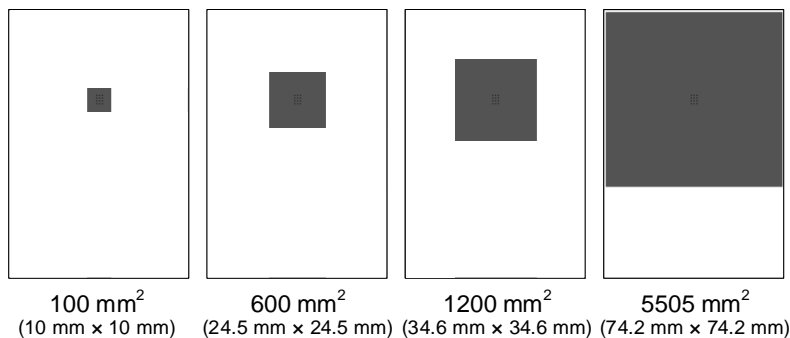

Figure 3-1-4-7. Bottom layer

3-1. 銅箔面積を変化 (つづき)

3-1-5. 6層、複数層で銅箔面積を変化した場合

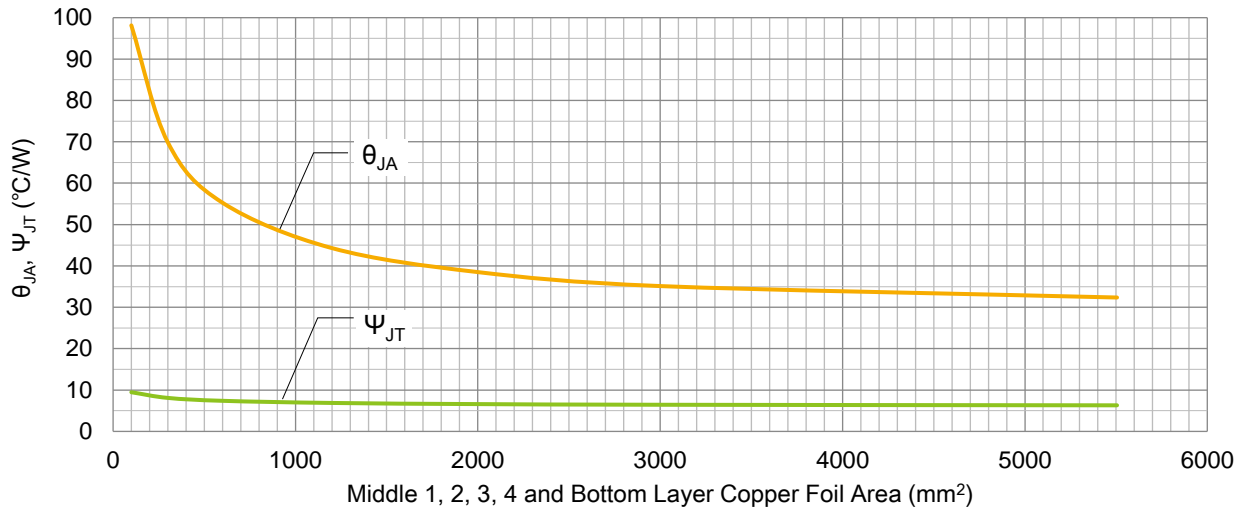

Figure 3-1-5-1. θ_{JA} , ψ_{JT} vs 銅箔面積

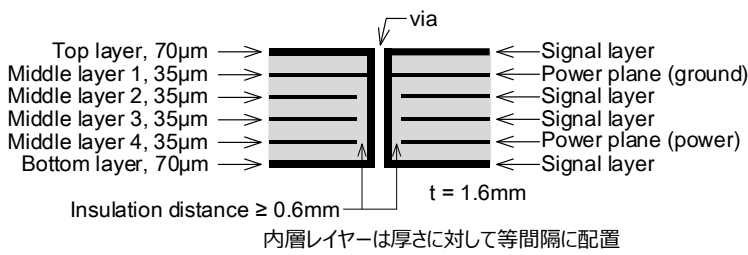

Figure 3-1-5-2. 6層基板断面図

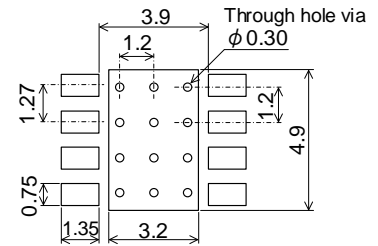

Figure 3-1-5-3. Footprint 寸法

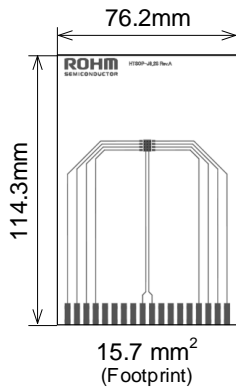

Figure 3-1-5-4. Top layer

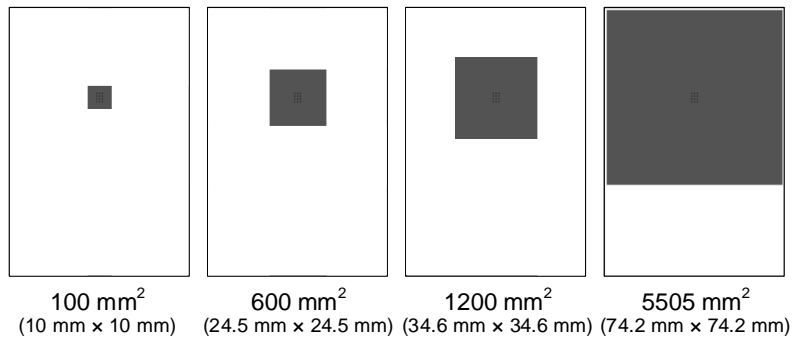

Figure 3-1-5-5. Middle layer 1, Bottom layer

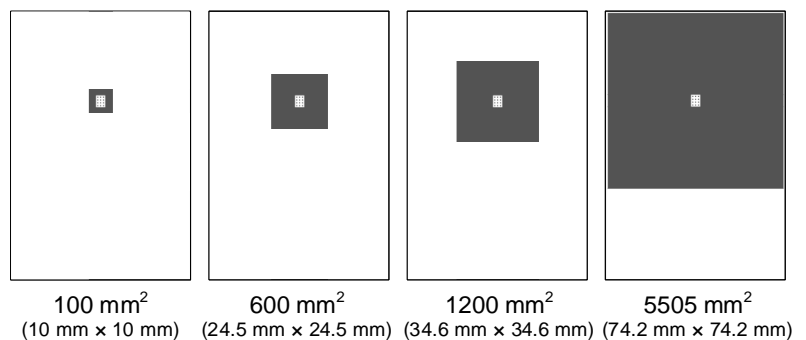

Figure 3-1-5-6. Middle layer 2, 3, 4

3-1. 銅箔面積を変化 (つづき)

3-1-6. 6層、Bottom layerのみ銅箔面積を変化した場合

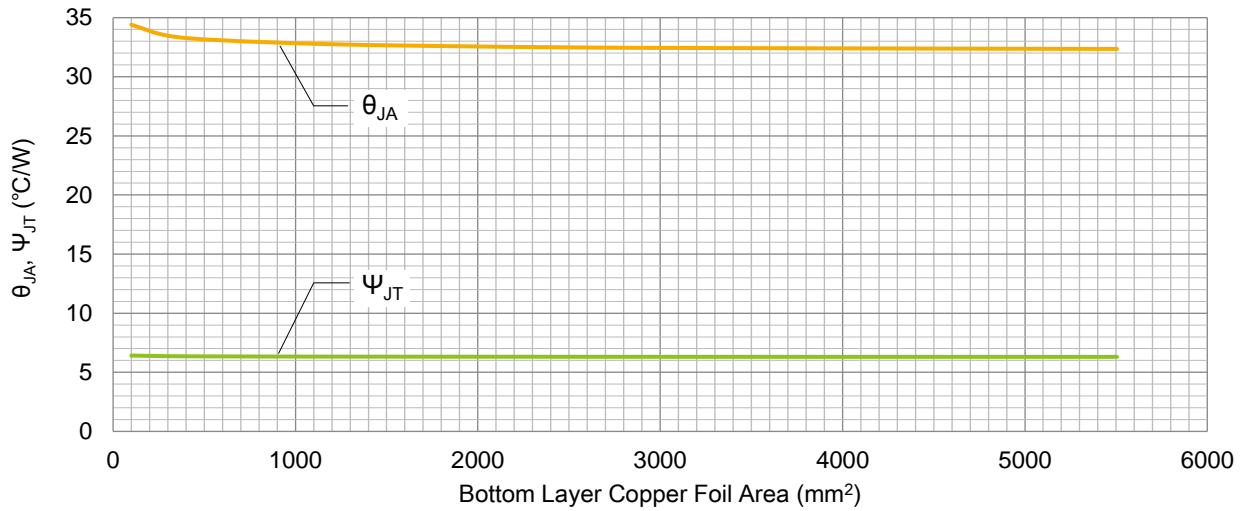
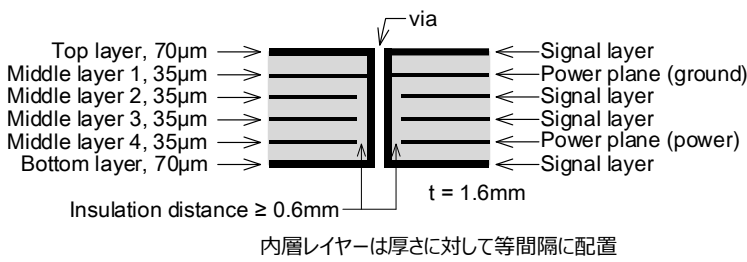

Figure 3-1-6-1. θ_{JA} , ψ_{JT} vs 銅箔面積



内層レイヤーは厚さに対して等間隔に配置
Figure 3-1-6-2. 6層基板断面図

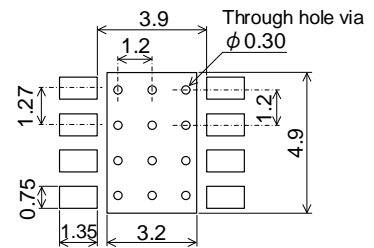

Figure 3-1-6-3. Footprint 寸法

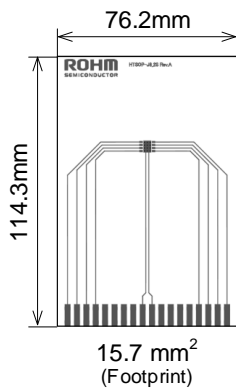

Figure 3-1-6-4. Top layer

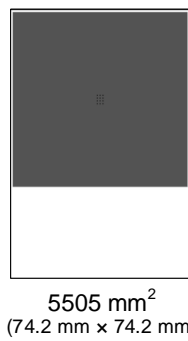

Figure 3-1-6-5. Middle layer 1

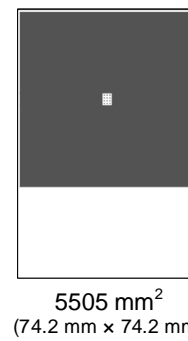

Figure 3-1-6-6. Middle layer 2, 3, 4

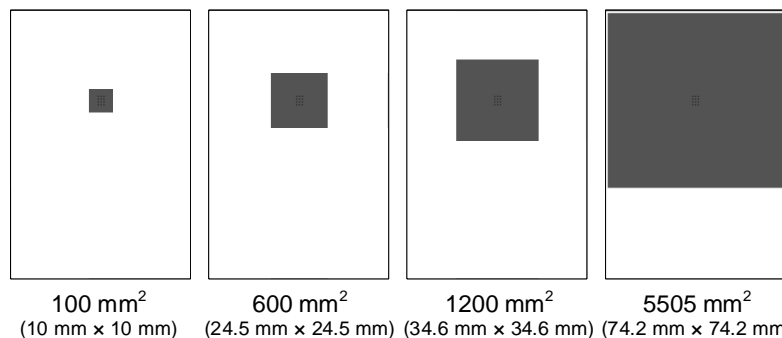

Figure 3-1-4-7. Bottom layer

3-1. 銅箔面積を変化 (つづき)

3-1-7. 8層、複数層で銅箔面積を変化した場合

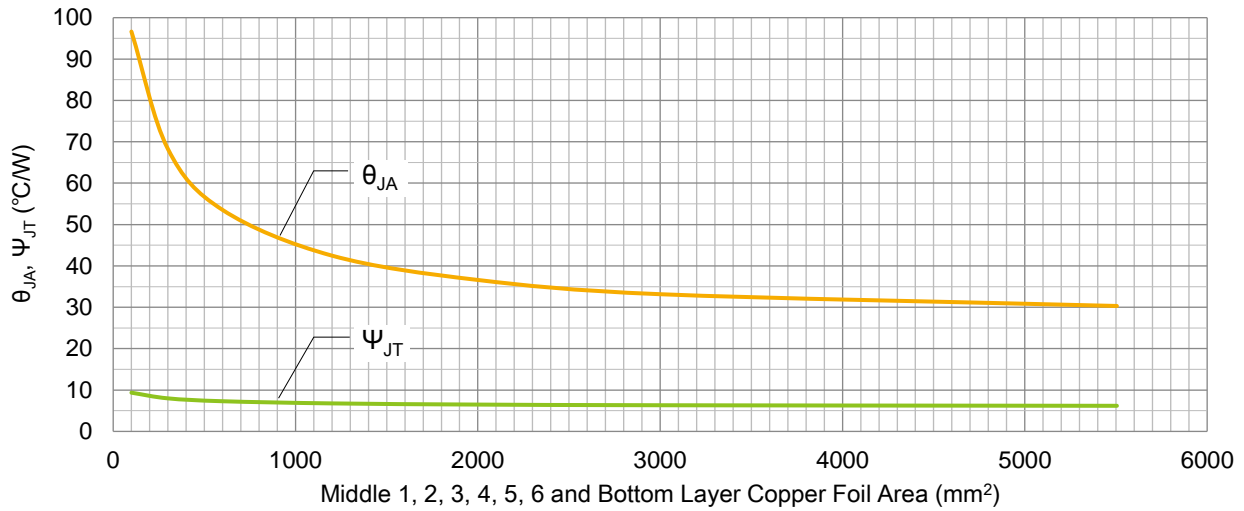

Figure 3-1-7-1. θ_{JA} , ψ_{JT} vs 銅箔面積

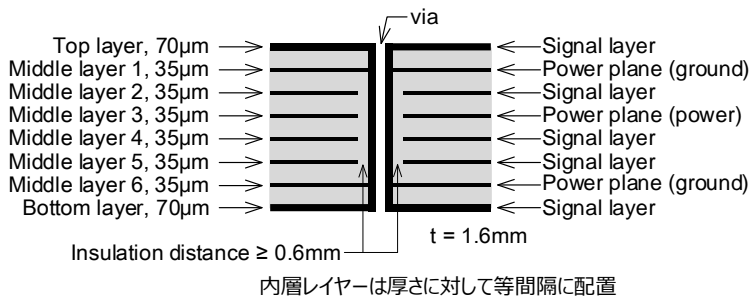

Figure 3-1-7-2. 8層基板断面図

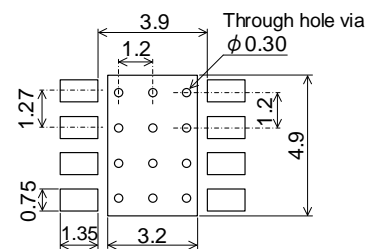

Figure 3-1-7-3. Footprint 寸法

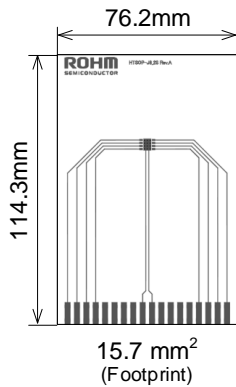

Figure 3-1-7-4. Top layer

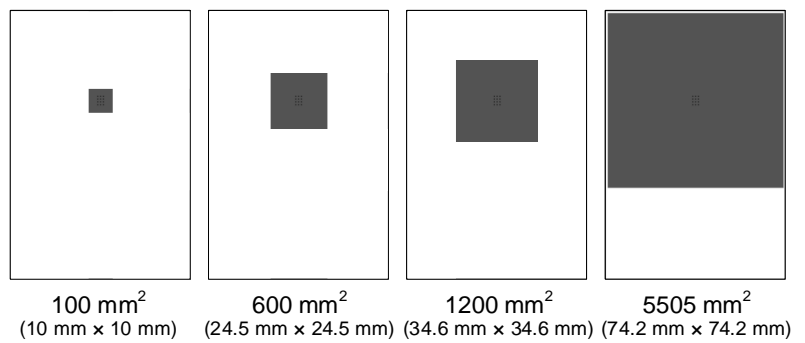

Figure 3-1-7-5. Middle layer 1, 6, Bottom layer

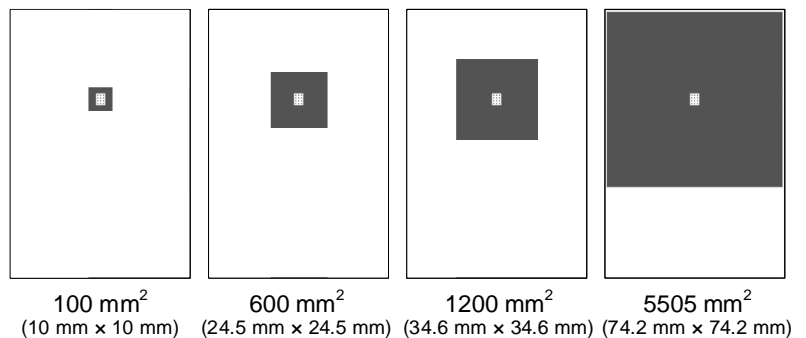

Figure 3-1-7-6. Middle layer 2, 3, 4, 5

3-1. 銅箔面積を変化 (つづき)

3-1-8. 8層、Bottom layerのみ銅箔面積を変化した場合

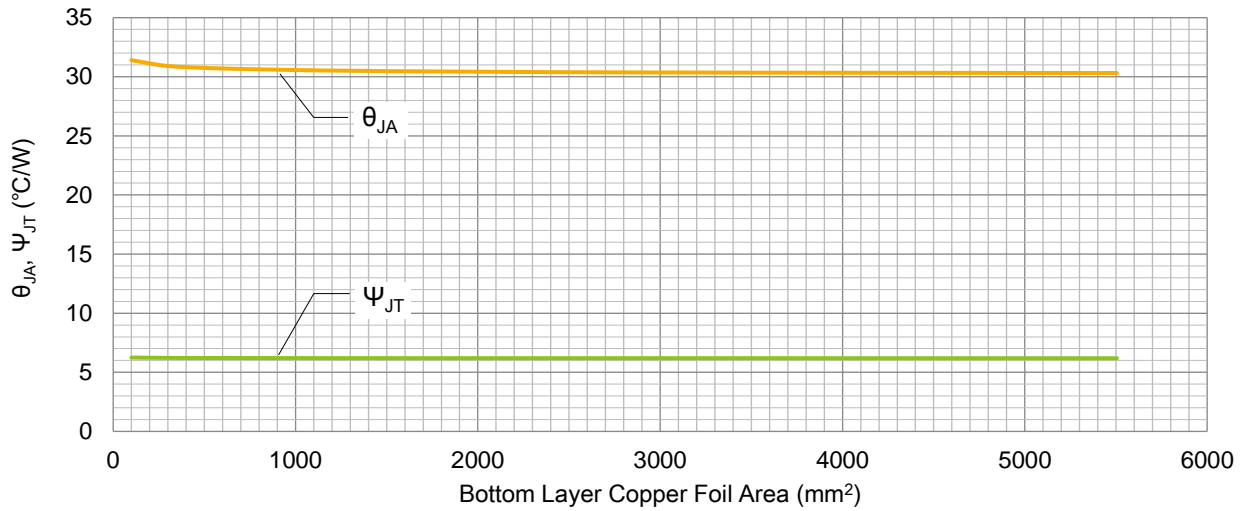

Figure 3-1-8-1. θ_{JA} , ψ_{JT} vs 銅箔面積

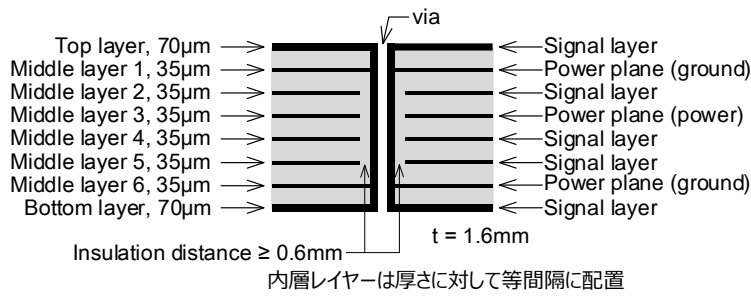

Figure 3-1-8-2. 8層基板断面図

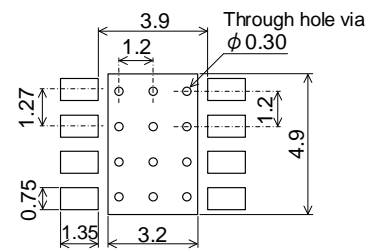

Figure 3-1-8-3. Footprint 寸法

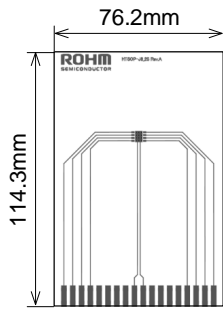

Figure 3-1-8-4. Top layer

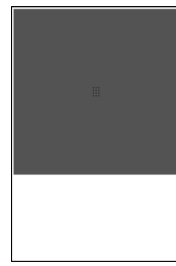

Figure 3-1-8-5. Middle layer 1, 6

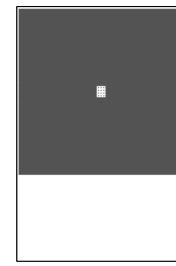

Figure 3-1-8-6. Middle layer 2, 3, 4, 5

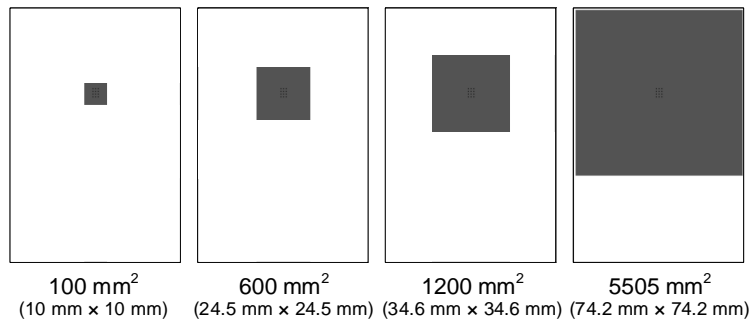

Figure 3-1-8-7. Bottom layer

3-2. 銅箔厚を变化

3-2-1. 1層

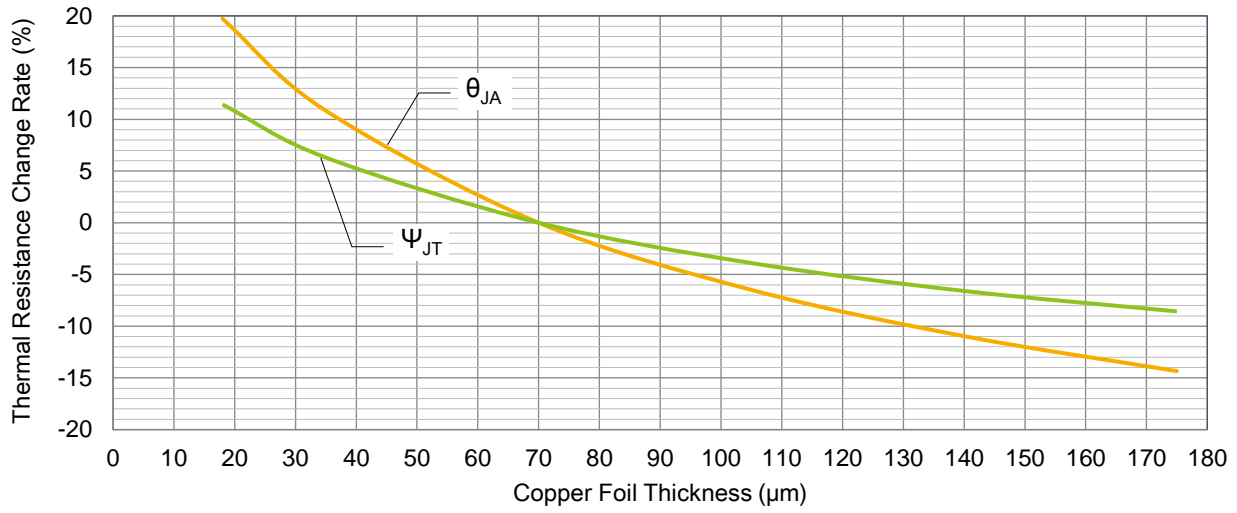

Figure 3-2-1-1. θ_{JA} , ψ_{JT} 変化率 vs 銅箔厚

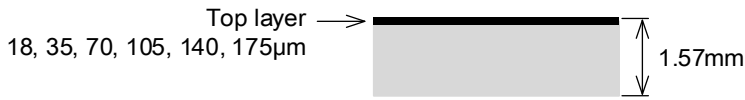

Figure 3-2-1-2. 1層基板断面図

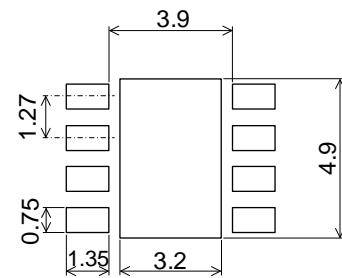

Figure 3-2-1-3. Footprint 寸法

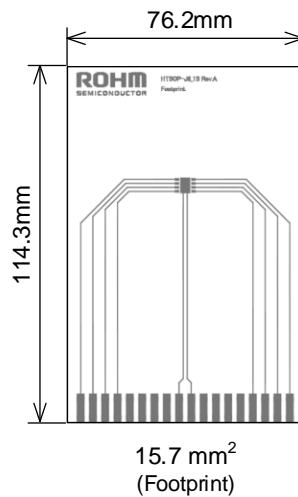

Figure 3-2-1-4. Top layer

3-2. 銅箔厚を変化 (つづき)

3-2-2. 2層

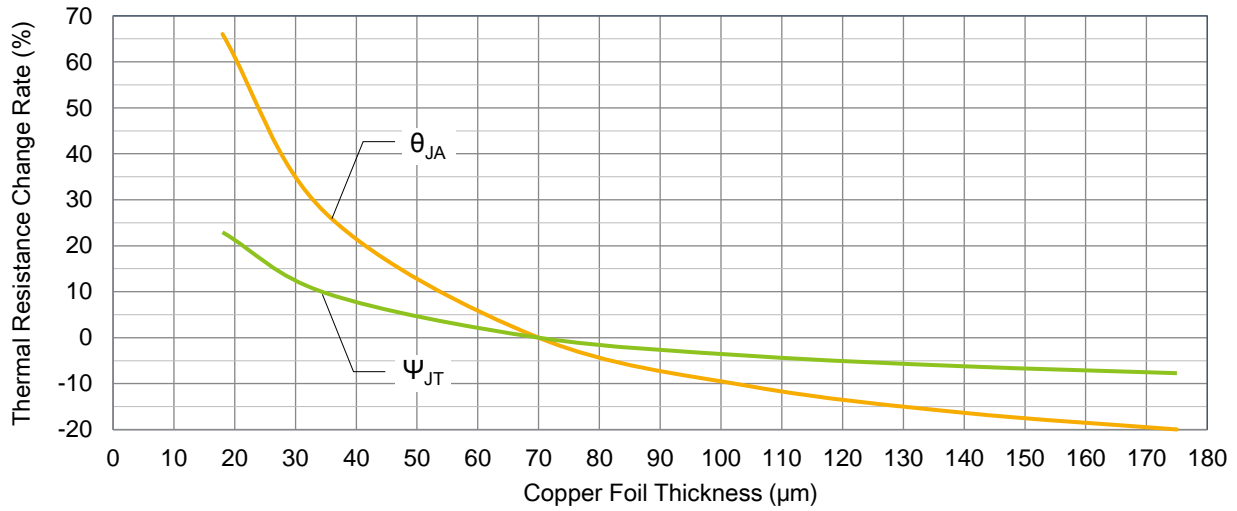

Figure 3-2-2-1. θ_{JA} , ψ_{JT} 変化率 vs 銅箔厚

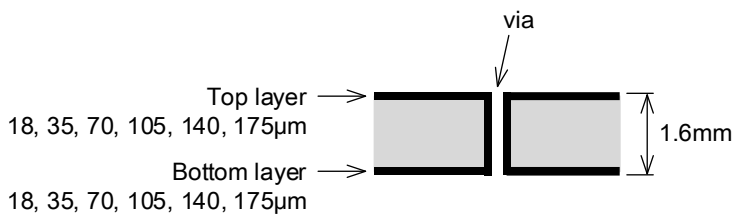

Figure 3-2-2-2. 2層基板断面図

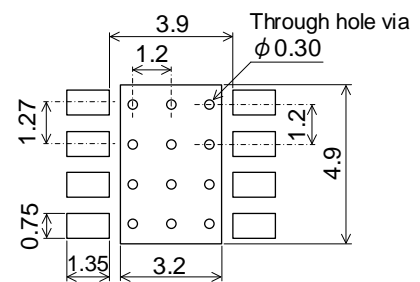

Figure 3-2-2-3. Footprint 寸法

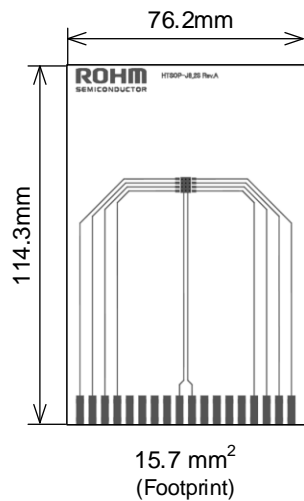

Figure 3-2-2-4. Top layer

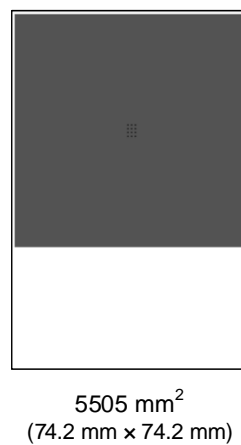

Figure 3-2-2-5. Bottom layer

3-2. 銅箔厚を変化 (つづき)

3-2-3. 4層

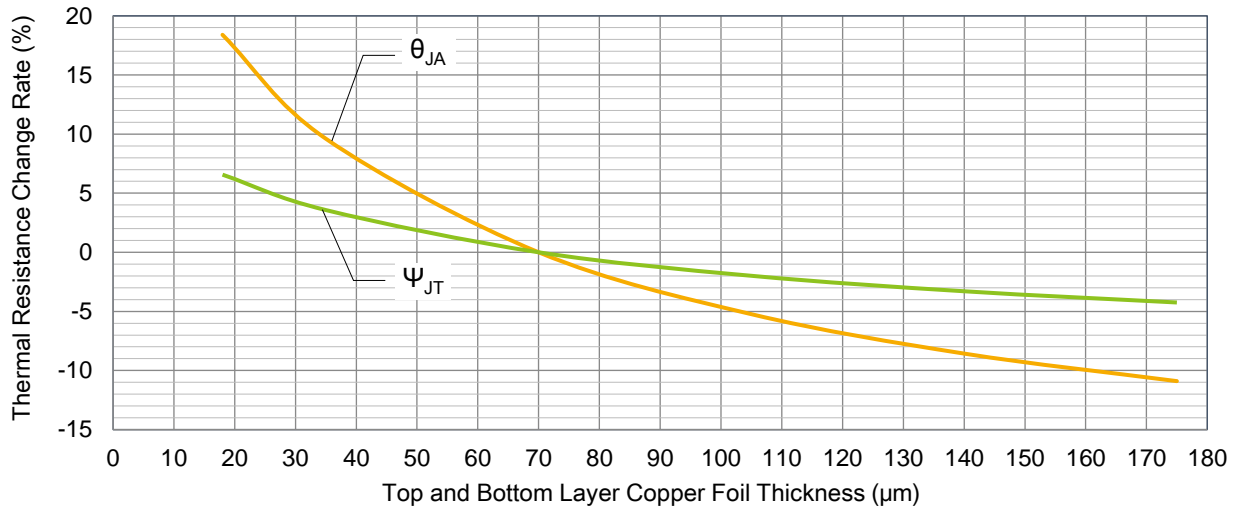

Figure 3-2-3-1. θ_{JA} , ψ_{JT} 変化率 vs 銅箔厚

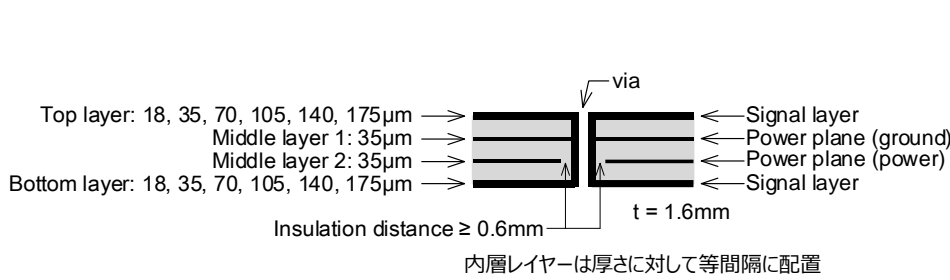

Figure 3-2-3-2. 4層基板断面図

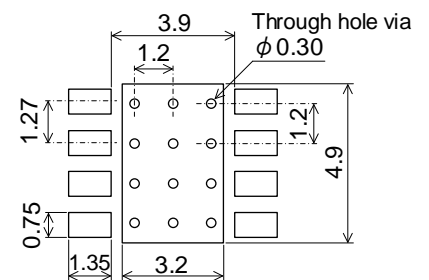

Figure 3-2-3-3. Footprint 寸法

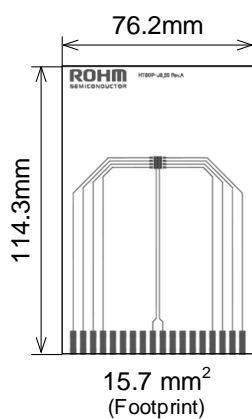

Figure 3-2-3-4. Top layer

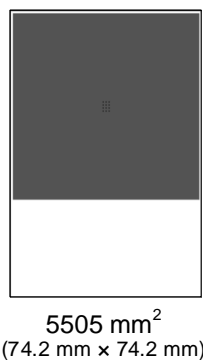

Figure 3-2-3-5. Middle layer 1

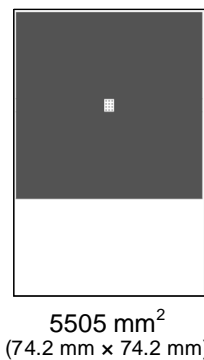

Figure 3-2-3-6. Middle layer 2

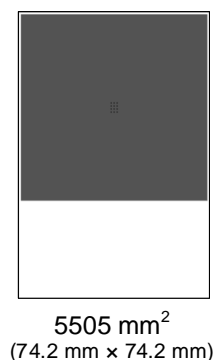

Figure 3-2-3-7. Bottom layer

3-3. サーマルビア配置

3-3-1. 2層

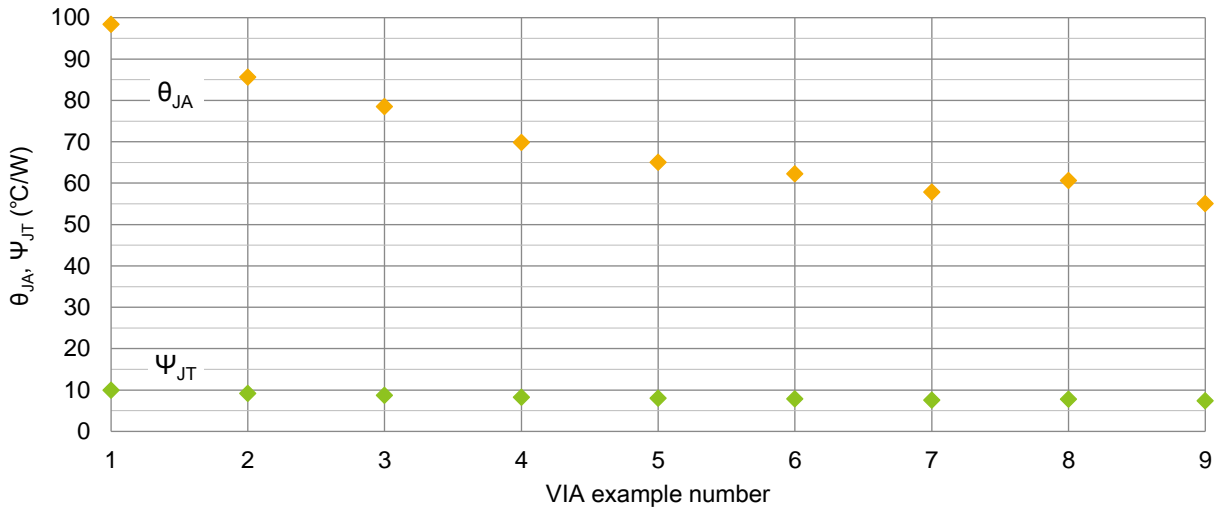

Figure 3-3-1-1. θ_{JA} , ψ_{JT} vs サーマルビア配置

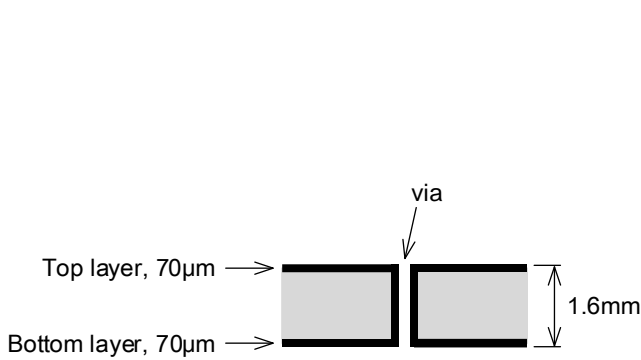

Figure 3-3-1-2. 2層基板断面図

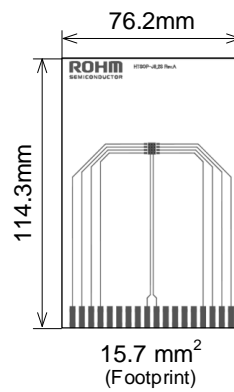

Figure 3-3-1-3. Top layer

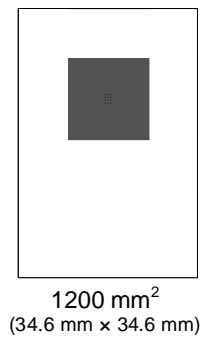
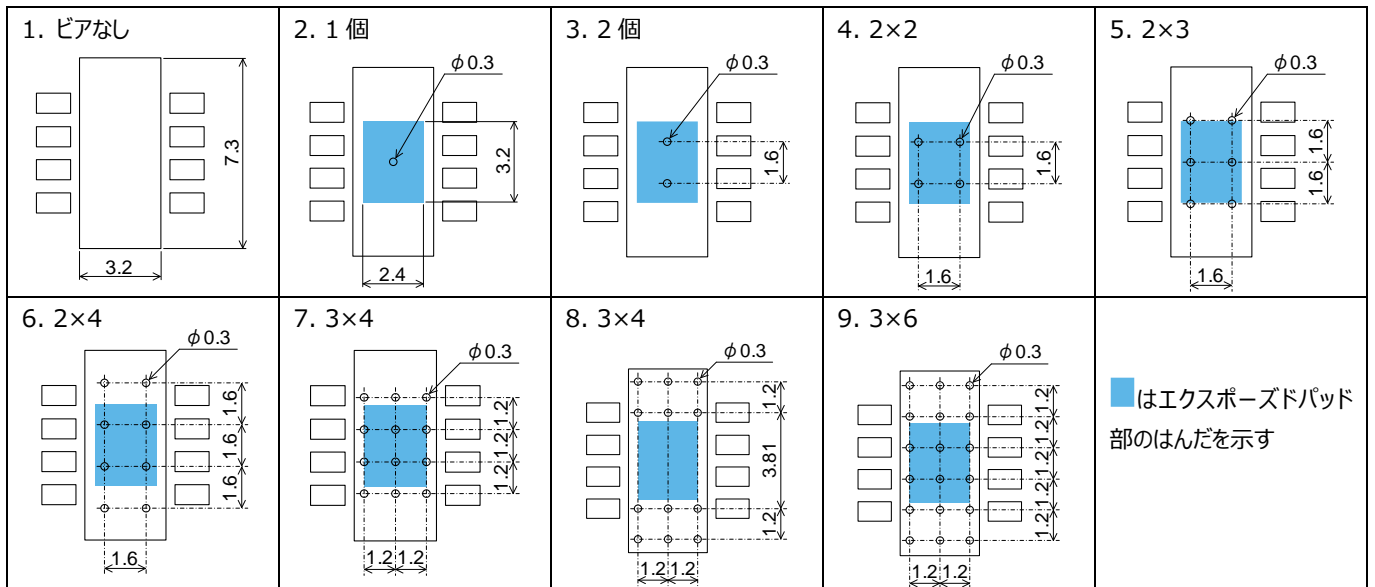

Figure 3-3-1-4. Bottom layer

ビア例の番号



3-3. サーマルビア配置 (つづき)

3-3-2. 4層

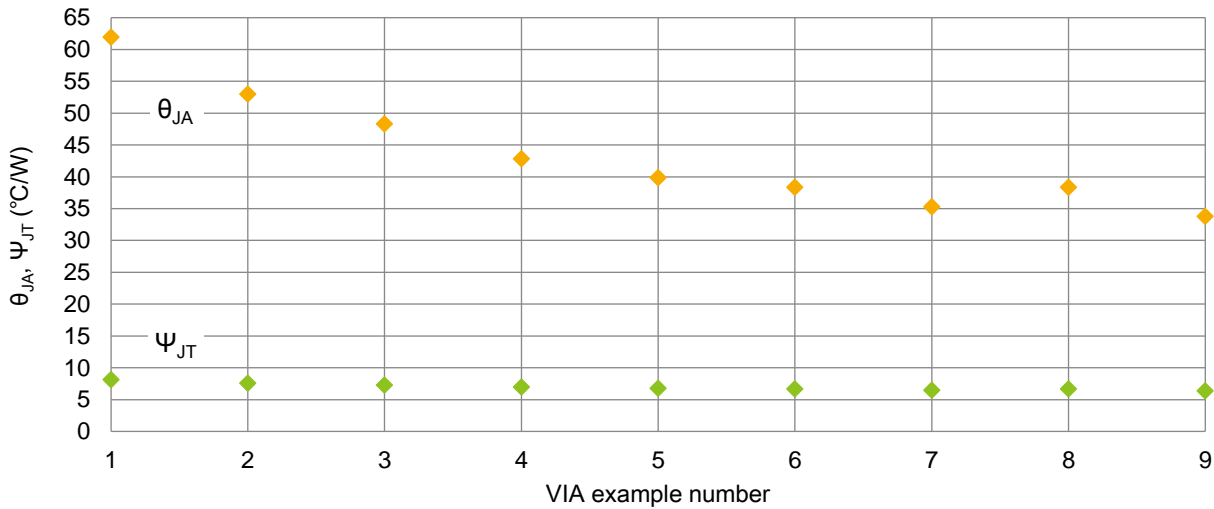

Figure 3-3-2-1. θ_{JA} , ψ_{JT} vs サーマルビア配置

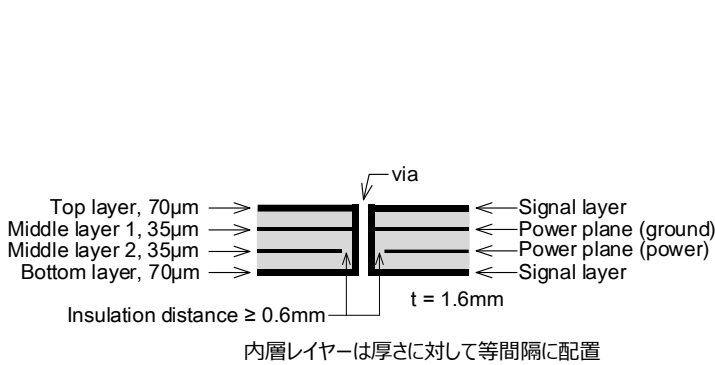

Figure 3-3-2-2. 4層基板断面図

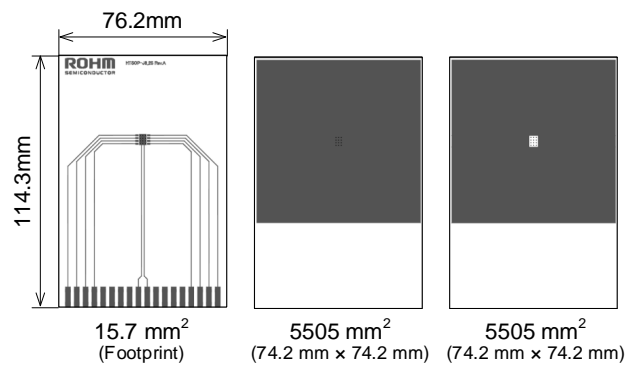
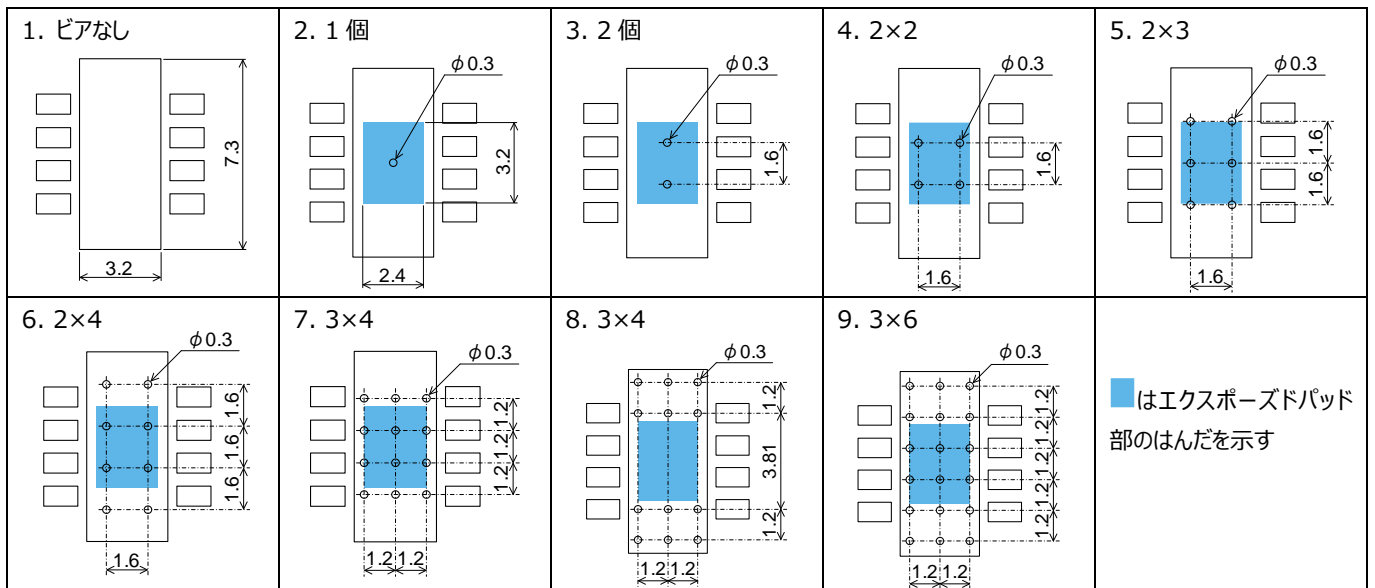

Figure 3-3-2-3. Top layer
Figure 3-3-2-4. Middle layer 1, Bottom layer
Figure 3-3-2-5. Middle layer 2

ビア例の番号



3-4. 基板厚を変化

3-4-1. 1層

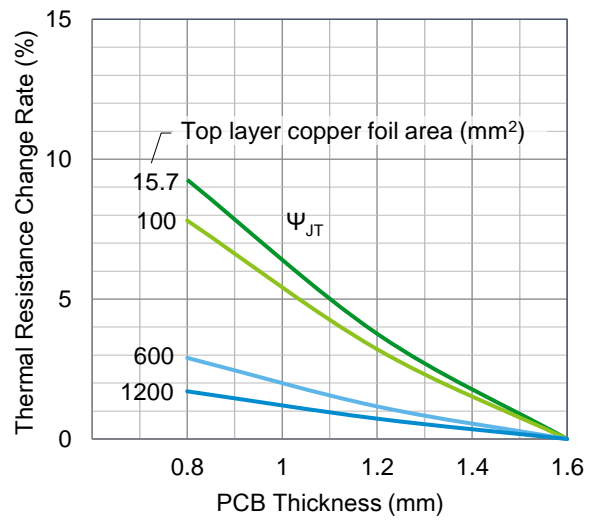
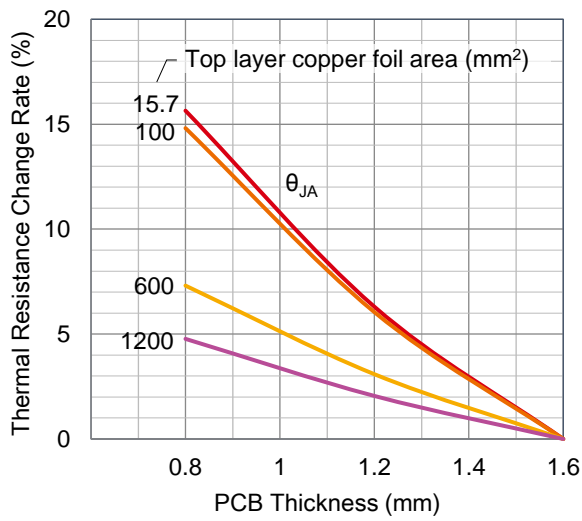

Figure 3-4-1-1. θ_{JA} , ψ_{JT} 変化率 vs 基板厚



Figure 3-4-1-2. 1層基板断面図

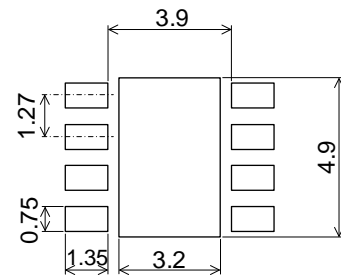

Figure 3-4-1-3. Footprint 寸法

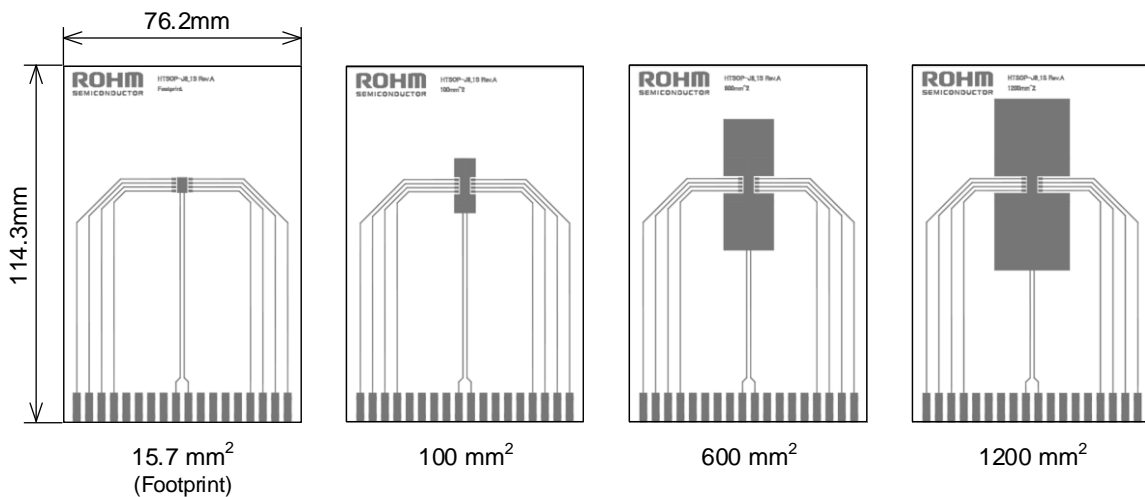

Figure 3-4-1-4. Top layer

3-4. 基板厚を変化 (つづき)

3-4-2. 2層

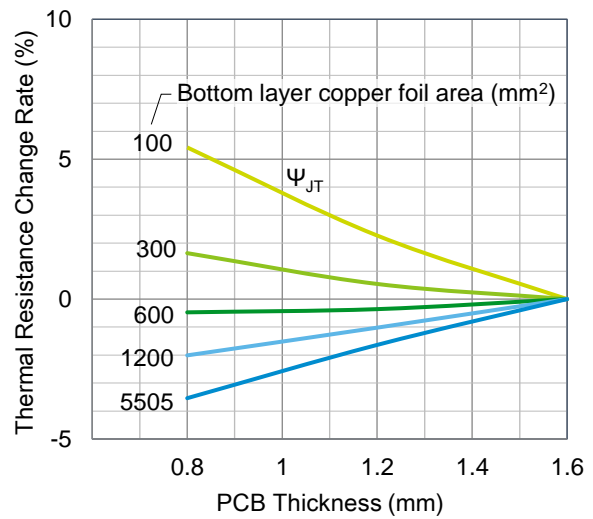
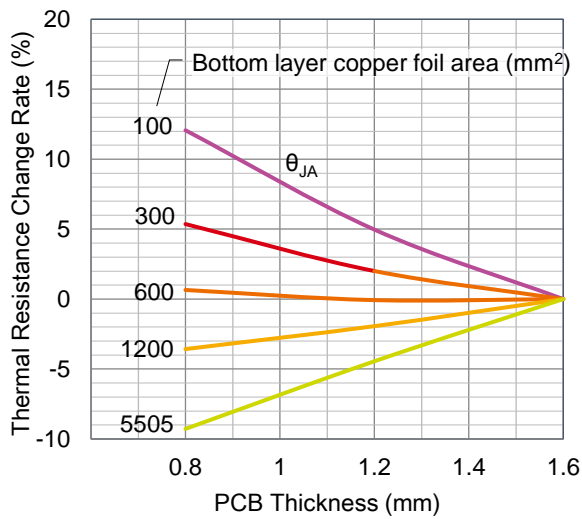

Figure 3-4-2-1. θ_{JA} , ψ_{JT} 変化率 vs 基板厚

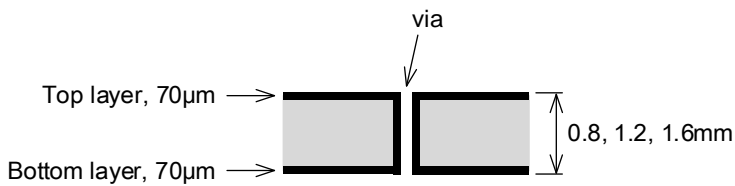

Figure 3-4-2-2. 2層基板断面図

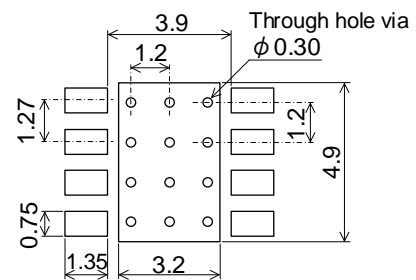

Figure 3-4-2-3. Footprint 寸法

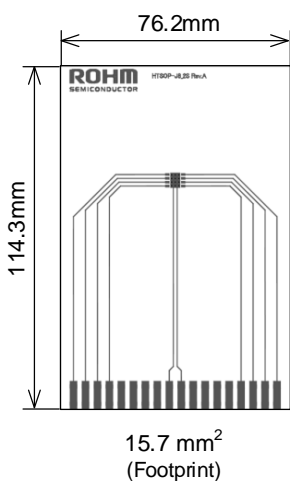

Figure 3-4-2-4. Top layer

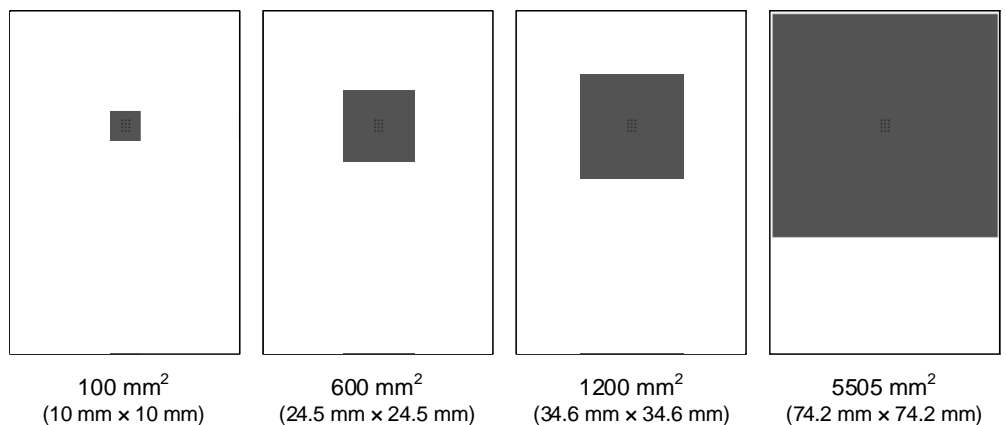

Figure 3-4-2-5. Bottom layer

3-4. 基板厚を変化 (つづき)

3-4-3. 4 層

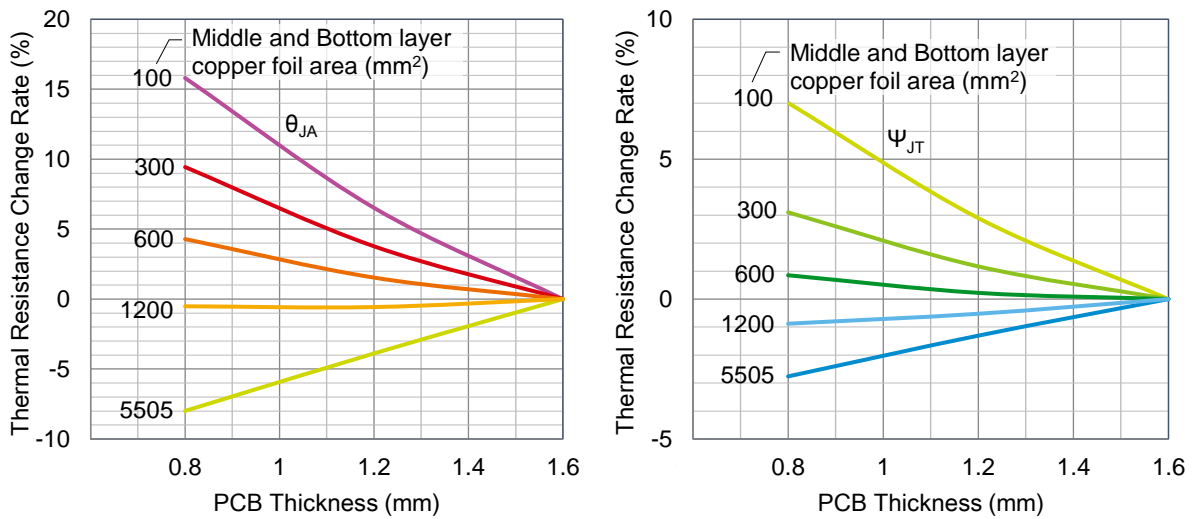

Figure 3-4-3-1. θ_{JA} , ψ_{JT} 変化率 vs 基板厚

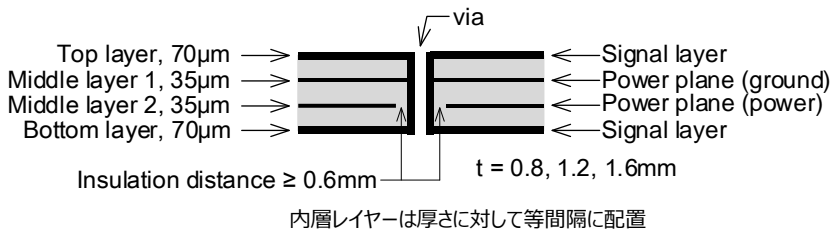

Figure 3-4-3-2. 4層基板断面図

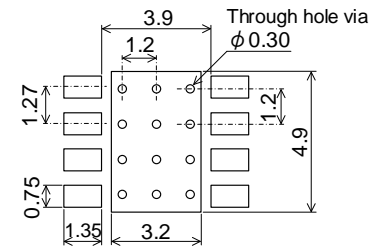

Figure 3-4-3-3. Footprint 寸法

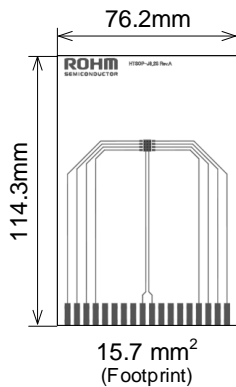

Figure 3-4-3-4. Top layer

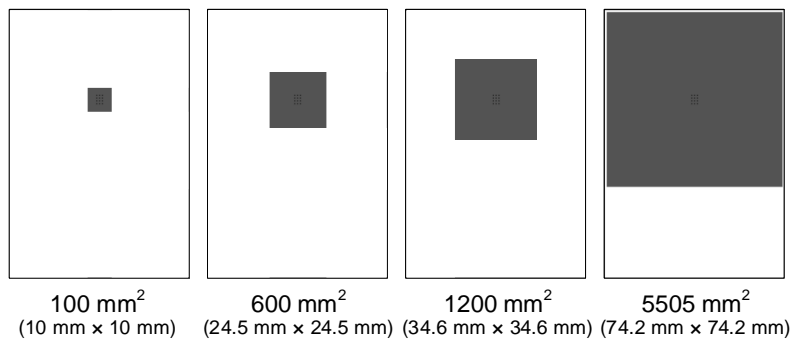

Figure 3-4-3-5. Middle layer 1, Bottom layer

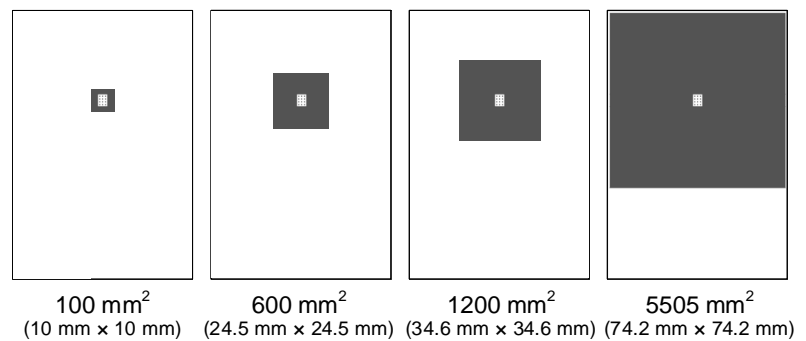
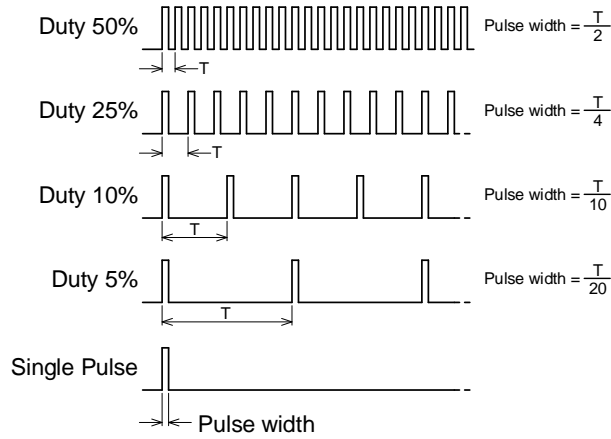

Figure 3-4-3-6. Middle layer 2

4. 過渡熱抵抗

グラフ軸の説明

X 軸 : Pulse width はデバイスへの電力印加時間



Y 軸 : 過渡熱抵抗

4-1. 過渡熱抵抗 1 層



Figure 4-1-1. 1 層基板断面図

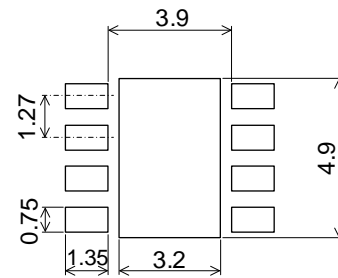

Figure 4-1-2. Footprint 寸法

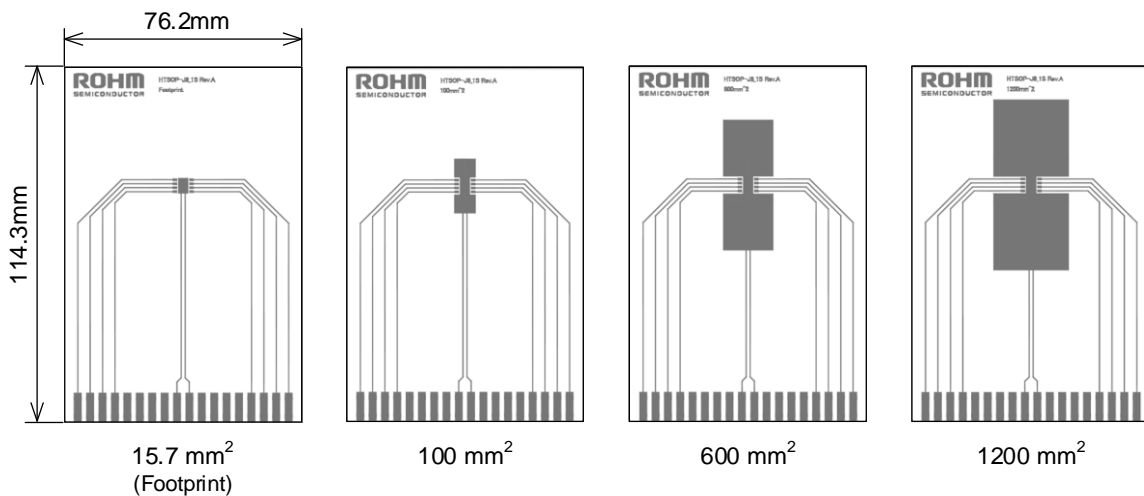

Figure 4-1-3. Top layer

4-1. 過渡熱抵抗 1 層 (つづき)

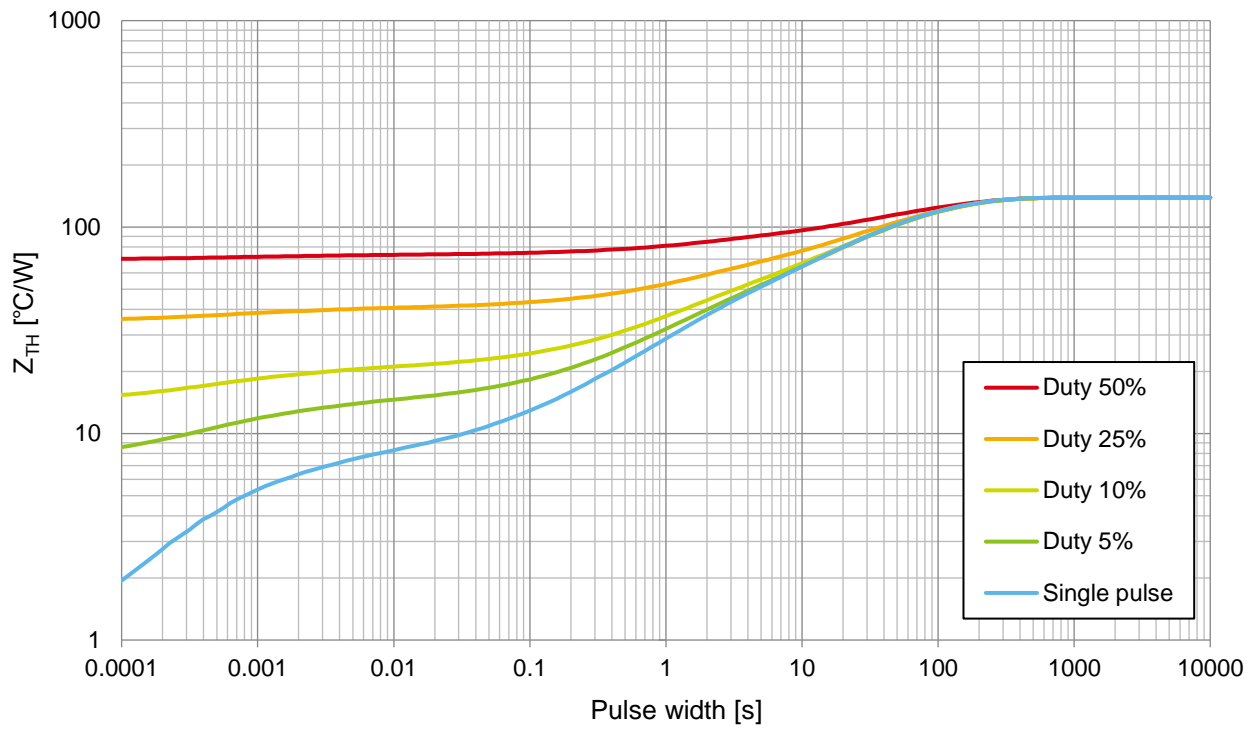

Figure 4-1-4. 過渡熱抵抗 1 層
銅箔面積 15.7mm² (Footprint)

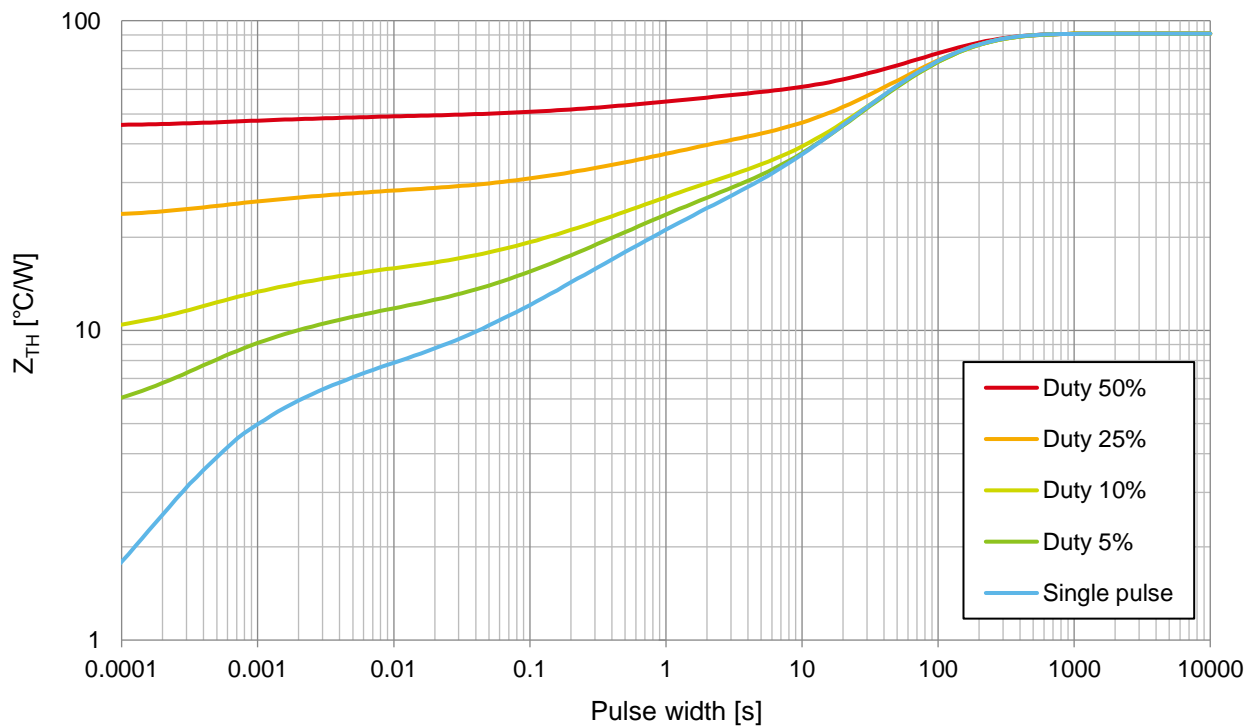

Figure 4-1-5. 過渡熱抵抗 1 層
銅箔面積 100mm²

4-1. 過渡熱抵抗 1 層 (つづき)

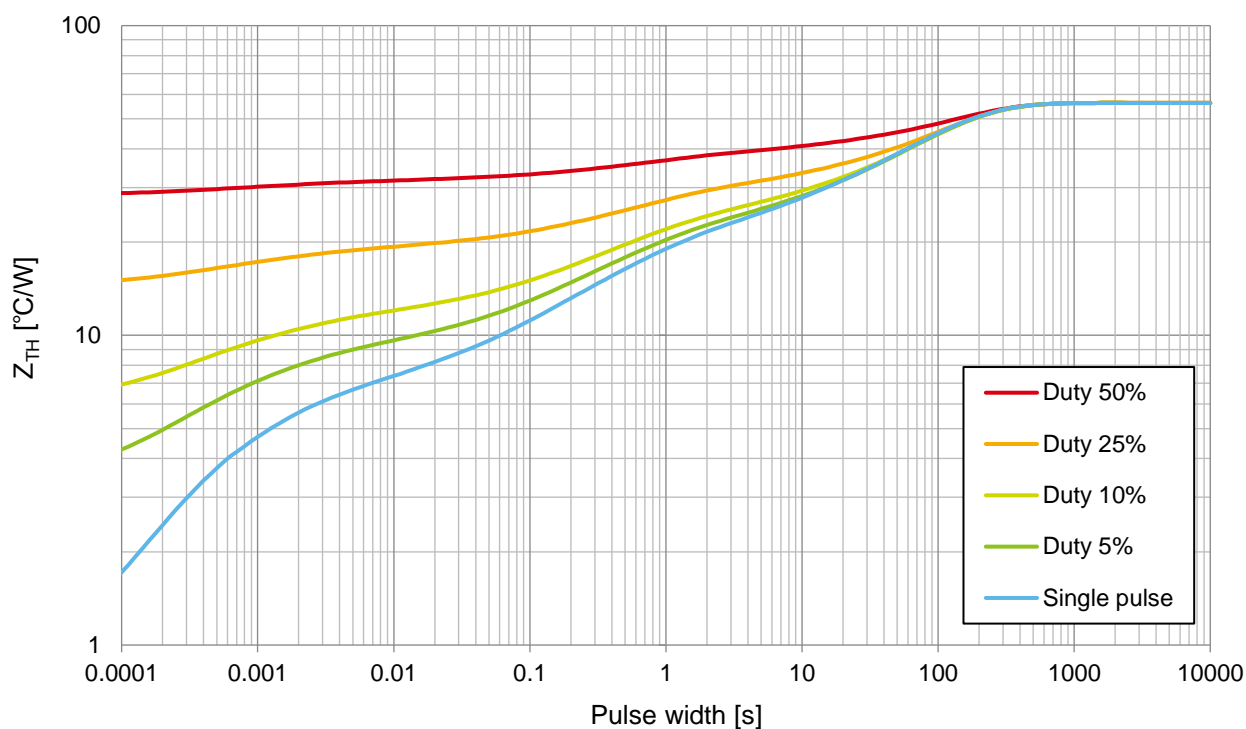

Figure 18. 過渡熱抵抗 1 層
銅箔面積 600mm²

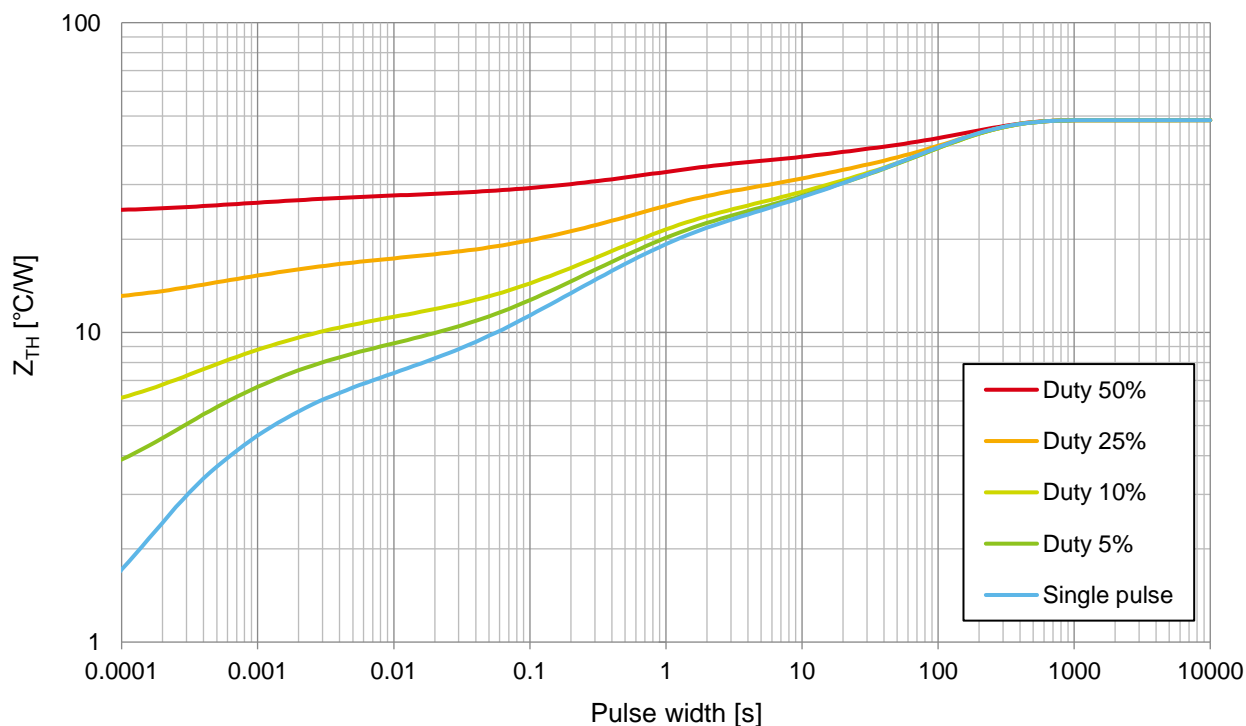

Figure 19. 過渡熱抵抗 1 層
銅箔面積 1200mm²

4-2. 過渡熱抵抗 2 層

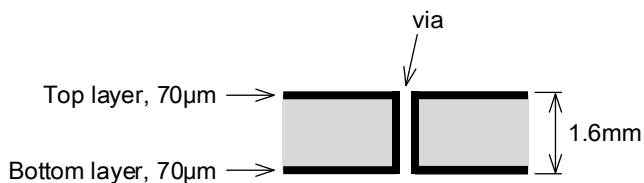

Figure 4-2-1. 2層基板断面図

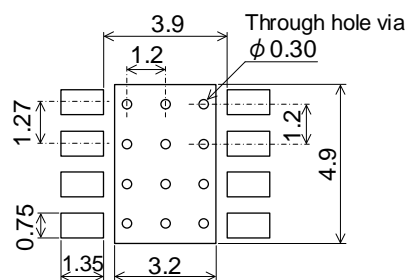

Figure 4-2-2. Footprint 寸法

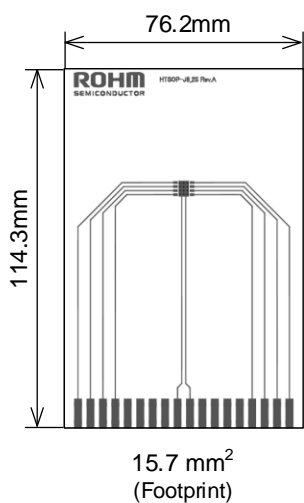

Figure 4-2-3. Top layer

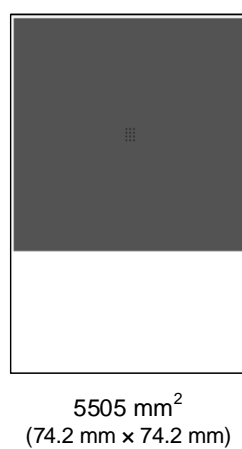

Figure 4-2-4. Bottom layer

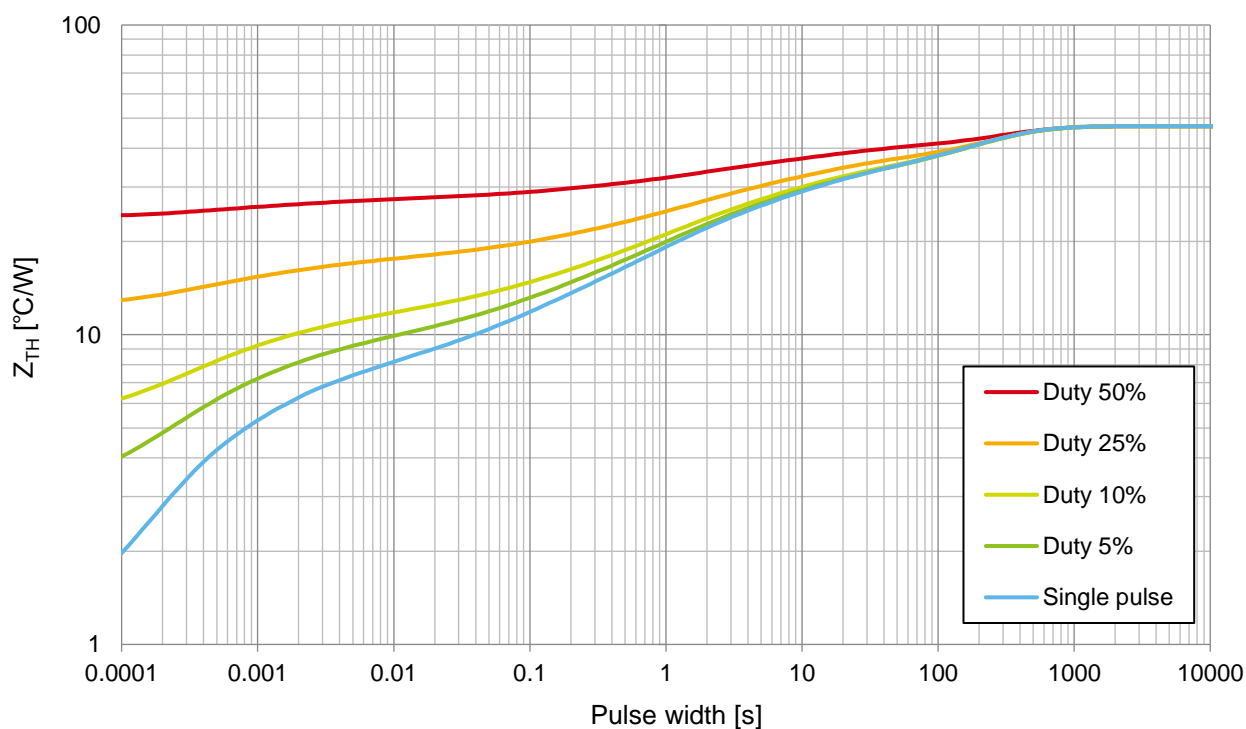

Figure 4-2-5. 過渡熱抵抗 2 層

4-3. 過渡熱抵抗 4層

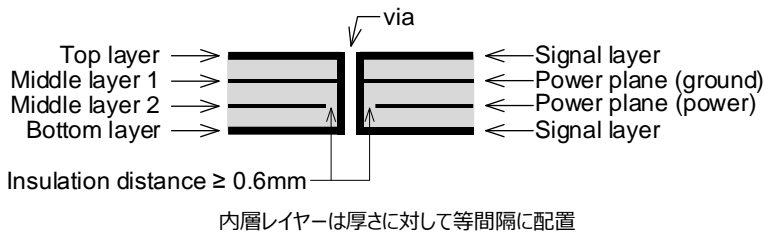

Figure 4-3-1. 4層基板断面図

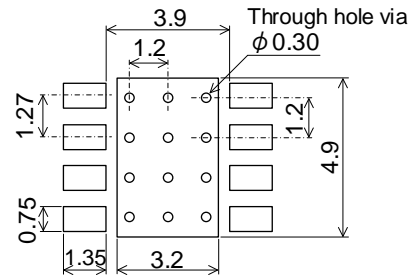

Figure 4-3-2. Footprint 寸法

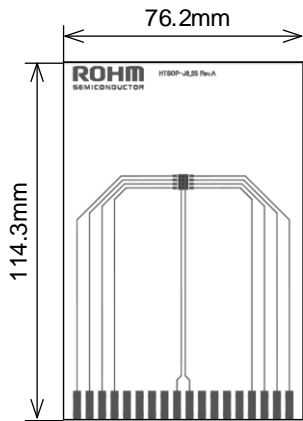

Figure 4-3-3. Top layer

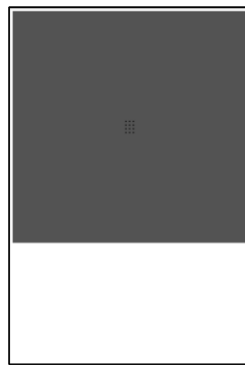

Figure 4-3-4. Middle 1 layer

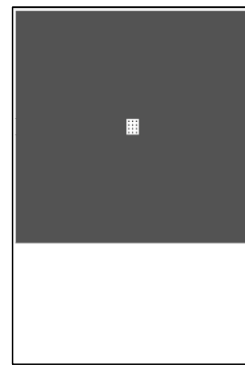

Figure 4-3-5. Middle 2 layer

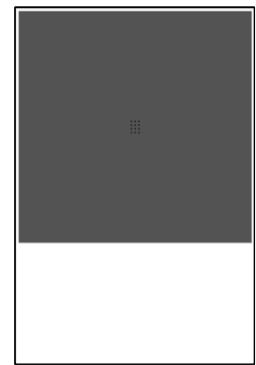

Figure 4-3-6. Bottom layer

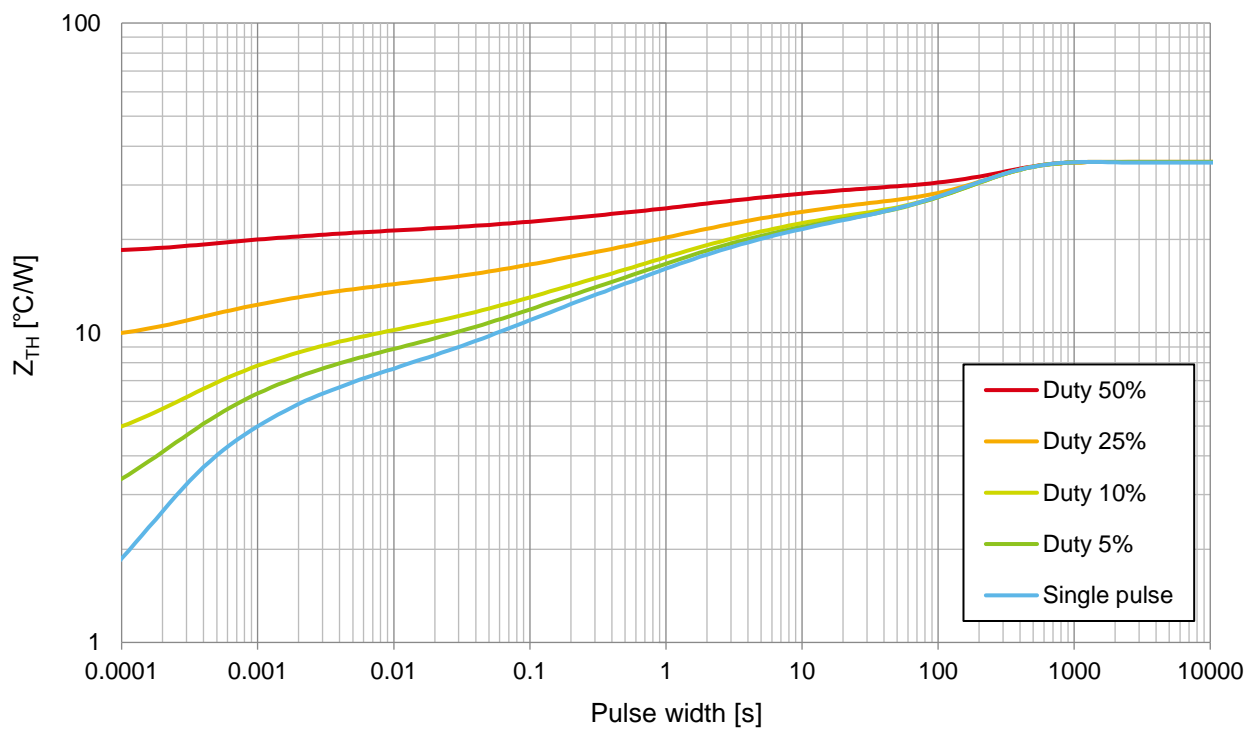

Figure 4-3-7. 過渡熱抵抗 4層