



Dear customer

ROHM Co., Ltd. ("ROHM"), on the 1st day of April, 2024,
has absorbed into merger with 100%-owned subsidiary of LAPIS Technology Co., Ltd.

Therefore, all references to "LAPIS Technology Co., Ltd.", "LAPIS Technology"
and/or "LAPIS" in this document shall be replaced with "ROHM Co., Ltd."

Furthermore, there are no changes to the documents relating to our products other than
the company name, the company trademark, logo, etc.

Thank you for your understanding.

ROHM Co., Ltd.
April 1, 2024

Dear customer

LAPIS Semiconductor Co., Ltd. ("LAPIS Semiconductor"), on the 1st day of October, 2020, implemented the incorporation-type company split (shinsetsu-bunkatsu) in which LAPIS established a new company, LAPIS Technology Co., Ltd. ("LAPIS Technology") and LAPIS Technology succeeded LAPIS Semiconductor's LSI business.

Therefore, all references to "LAPIS Semiconductor Co., Ltd.", "LAPIS Semiconductor" and/or "LAPIS" in this document shall be replaced with "LAPIS Technology Co., Ltd."

Furthermore, there are no changes to the documents relating to our products other than the company name, the company trademark, logo, etc.

Thank you for your understanding.

LAPIS Technology Co., Ltd.
October 1, 2020

ML62Q1432 Reference Board User's Manual

Issue Date: October 10, 2017



LAPIS Semiconductor Co.,Ltd.NOTES

- 1) The information contained herein is subject to change without notice.
- 2) Although LAPIS Semiconductor is continuously working to improve product reliability and quality, semiconductors can break down and malfunction due to various factors. Therefore, in order to prevent personal injury or fire arising from failure, please take safety measures such as complying with the derating characteristics, implementing redundant and fire prevention designs, and utilizing backups and fail-safe procedures. LAPIS Semiconductor shall have no responsibility for any damages arising out of the use of our Products beyond the rating specified by LAPIS Semiconductor.
- 3) Examples of application circuits, circuit constants and any other information contained herein are provided only to illustrate the standard usage and operations of the Products. The peripheral conditions must be taken into account when designing circuits for mass production.
- 4) The technical information specified herein is intended only to show the typical functions of the Products and examples of application circuits for the Products. No license, expressly or implied, is granted hereby under any intellectual property rights or other rights of LAPIS Semiconductor or any third party with respect to the information contained in this document; therefore LAPIS Semiconductor shall have no responsibility whatsoever for any dispute, concerning such rights owned by third parties, arising out of the use of such technical information.
- 5) The Products are intended for use in general electronic equipment (i.e. AV/OA devices, communication, consumer systems, gaming/entertainment sets) as well as the applications indicated in this document.
- 6) The Products specified in this document are not designed to be radiation tolerant.
- 7) For use of our Products in applications requiring a high degree of reliability (as exemplified below), please contact and consult with a LAPIS Semiconductor representative: transportation equipment (i.e. cars, ships, trains), primary communication equipment, traffic lights, fire/crime prevention, safety equipment, medical systems, servers, solar cells, and power transmission systems.
- 8) Do not use our Products in applications requiring extremely high reliability, such as aerospace equipment, nuclear power control systems, and submarine repeaters.
- 9) LAPIS Semiconductor shall have no responsibility for any damages or injury arising from non-compliance with the recommended usage conditions and specifications contained herein.
- 10) LAPIS Semiconductor has used reasonable care to ensure the accuracy of the information contained in this document. However, LAPIS Semiconductor does not warrant that such information is error-free and LAPIS Semiconductor shall have no responsibility for any damages arising from any inaccuracy or misprint of such information.
- 11) Please use the Products in accordance with any applicable environmental laws and regulations, such as the RoHS Directive. For more details, including RoHS compatibility, please contact a ROHM sales office. LAPIS Semiconductor shall have no responsibility for any damages or losses resulting non-compliance with any applicable laws or regulations.
- 12) When providing our Products and technologies contained in this document to other countries, you must abide by the procedures and provisions stipulated in all applicable export laws and regulations, including without limitation the US Export Administration Regulations and the Foreign Exchange and Foreign Trade Act.
- 13) This document, in part or in whole, may not be reprinted or reproduced without prior consent of LAPIS Semiconductor.

Copyright 2017 LAPIS Semiconductor Co., Ltd.

LAPIS Semiconductor Co.,Ltd.

2-4-8 Shinyokohama, Kouhoku-ku,
Yokohama 222-8575, Japan
<http://www.lapis-semi.com/en/>

Preface

This manual describes about the ML62Q1432 Reference Board :RB-D62Q1432TB48.

Refer to following documents when necessary.

- ML62Q1000 User's Manual
Describes about the microcontroller ML62Q1000 series.
- EASE1000 User's Manual
Describes about the On-chip emulator EASE1000.

1. Overview

1.1 Features

ML62Q1432 Reference Board is for learning how to use the ML62Q1432, on which adding external user components if necessary. Using ML62Q1432 Reference Board with LAPIS Semiconductor's on-chip emulator EASE1000 delivered with the software development environments, help user's software development and debugging and programming the Flash.

1.1.1 ML62Q1432 Reference Board features

- The board delivered with ML62Q1432 48pin TQFP .
- The connector linked to ESE1000 is mounted.
- Through-holes for connecting the pins of LSI to external peripheral boards.
- The power supply is selectable, supplied from the on-chip emulator EASE1000 or CN1_3pin / CN2_2pin.
- LED is mounted (P20, P21, P22)
- Crystal is mounted(32.768kHz)

1.1.2 ML62Q1432 Reference Board Hardware specifications

The hardware specification of ML62Q1432 Reference Board is indicated to Table 1.

Table.1 ML62Q1432 Reference Board Hardware specifications

Mounted LSI	U1 : ML62Q1432 48pin TQFP
Other Mounted components	PWR: Jumper for selecting the power supply input (3pin pin-header and short pin)
	J1: Jumper for selecting RESET_N pin (3pin pin-header and short pin)
	J2: Jumper for selecting P00/TEST0 pin (3pin pin-header and short pin)
	P20-P22: LEDs
	R1-R3: Resistors for LEDs by P20 to P22
	J3-J5: Jumper Chip for connecting LEDs
	X1, C3, C4: Crystal Oscillator(32.768kHz) and capacitors
	J8-J12: Jumper Chip for P75-P71
	CNE: Connector for EASE1000 (14pin connector)
	C1-C2: Capacitors for V _{DD} and V _{DDL}
	R4: Pull-up resistor for RESET_N
Pads (or/and) Through holes for mounting components	CN1-CN2: Connectors for user application system (25pin, 2.54mm pitch, φ 0.8mm)
Power check pin	VDD, VSS, UVDD: φ 0.8mm
Operating voltage	+1.6V to +5.5V
Board size	55.88 mm x 93.98 mm

See the schematic for more detail about connection of the mounted components.

1.2 ML62Q1432 Reference Board Outline Drawing

The Figure.1 show the ML62Q1432 Reference Board.

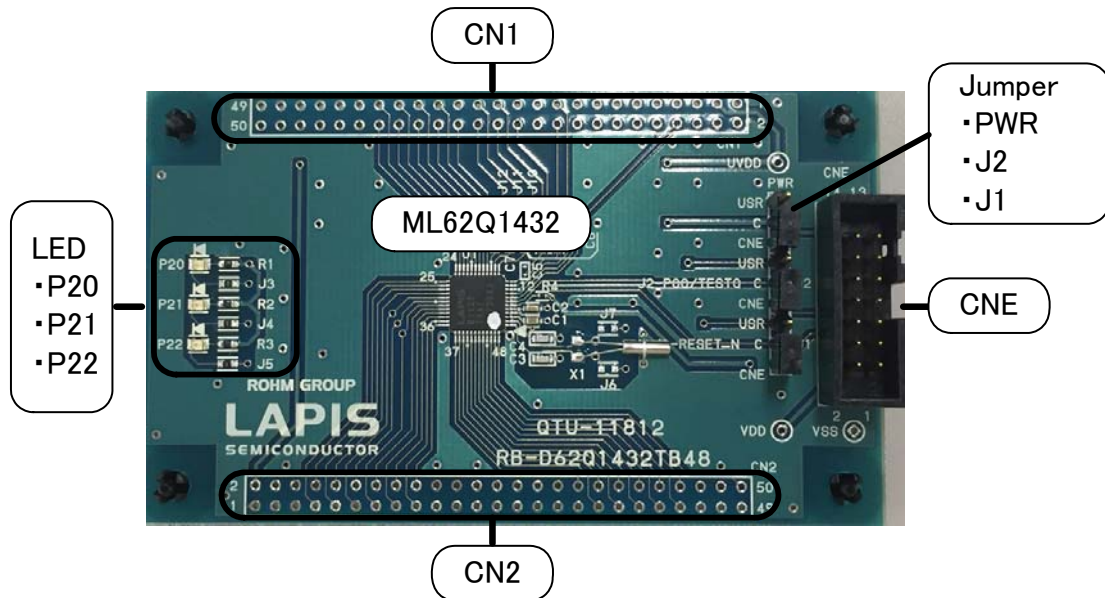

Fig.1 ML62Q1432 Reference Board Outline Drawing

2. Function of ML62Q1432 Reference Board

2.1 Power Circuit

V_{DD} can select the input from 3.3VOUT of EASE1000 or CN1_3pin / CN2_2pin by PWR jumper.

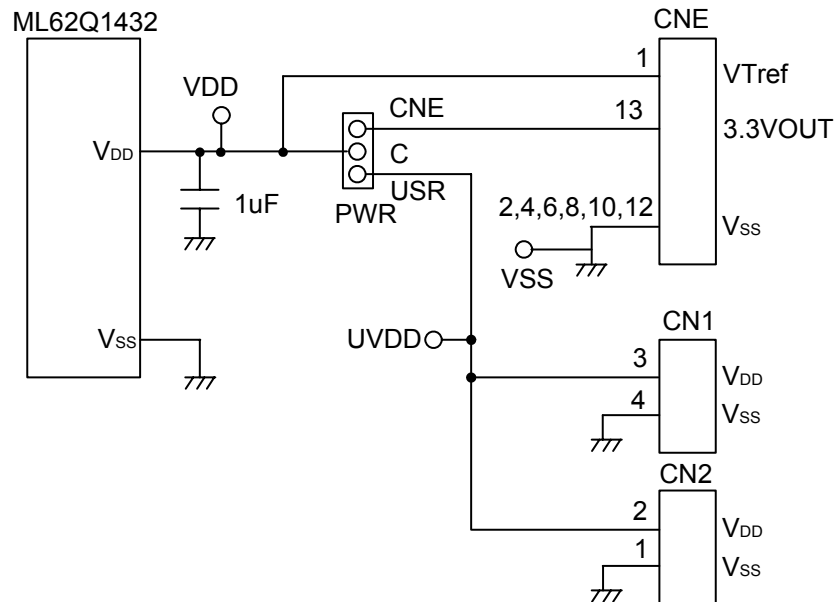

Fig.2 Power Circuit

[Note]

The power supply ON/OFF procedure in case of setting PWR jumper to the USB-side, and using EASE1000

- The procedure of power supply ON
 1. The USB cable of EASE1000 is connected.
 2. The power supply of user target system is turned on..
- The procedure of power supply OFF
 1. The power supply of user target system is turned off
 2. The .USB cable of EASE1000 is removed

2.2 Connector for EASE1000 (CNE)

EASE1000 can be used if J1 and J2 jumper are set to "CNE" .

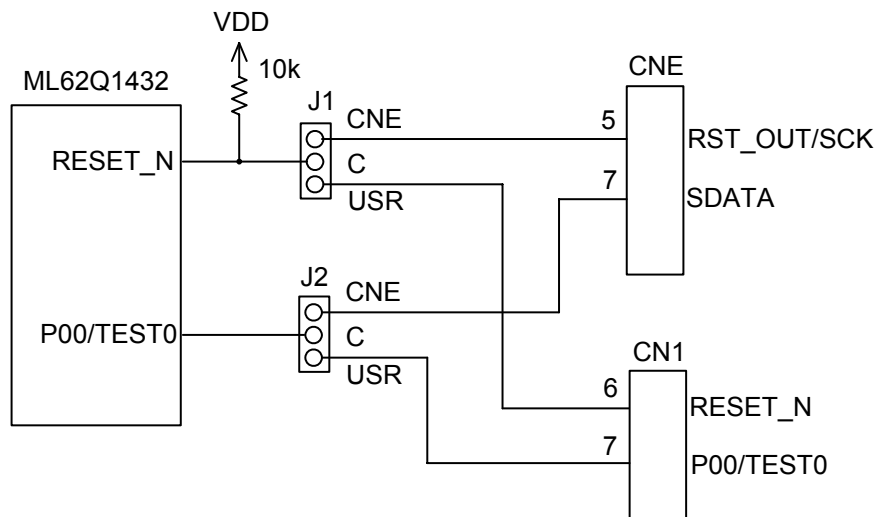

Fig.3 EASE1000 Interface

[Note]

P00/TEST0 pin:

P00/TEST0 pin of ML62Q1432 is initially set as the pulled-up input mode.

When using EASE1000 do not set it as an output mode by the application program, otherwise EASE1000 cannot communicate with the ML62Q1432.

2.3 LED (P20, P21, P22)

P20-P22 of the ML62Q1432 are ports that can directly drive a LED. The Ports are connected to the LEDs through jumper-chip. Remove the jumper-chip when not using the LEDs.

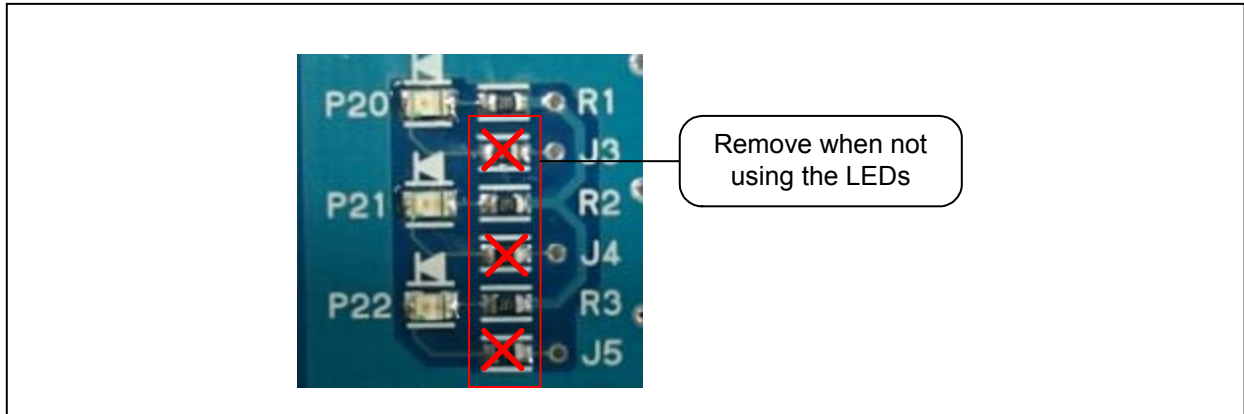

Fig.4 Jumper-chip removal of LEDs

2.4 XT0/PIO0, XT1/PIO1

ML62Q1432 Reference Borad can mount cylinder type or SMD type crystal oscillator.

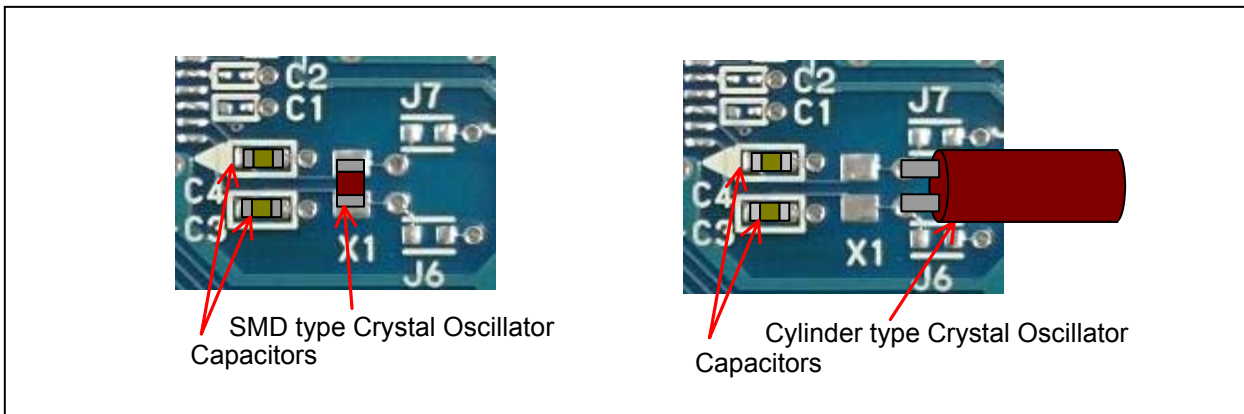

Fig.5 Example of processing of Crystal Oscillator

2.5 P75, P74, P73, P72, P71

P75 to P71 are connected with CN1 using jumper chip.
 ML62Q1432 Reference Board can not use C5, C6, C7 and C8.
 Therefore please do not mount various parts on C5, C6, C7 and C8

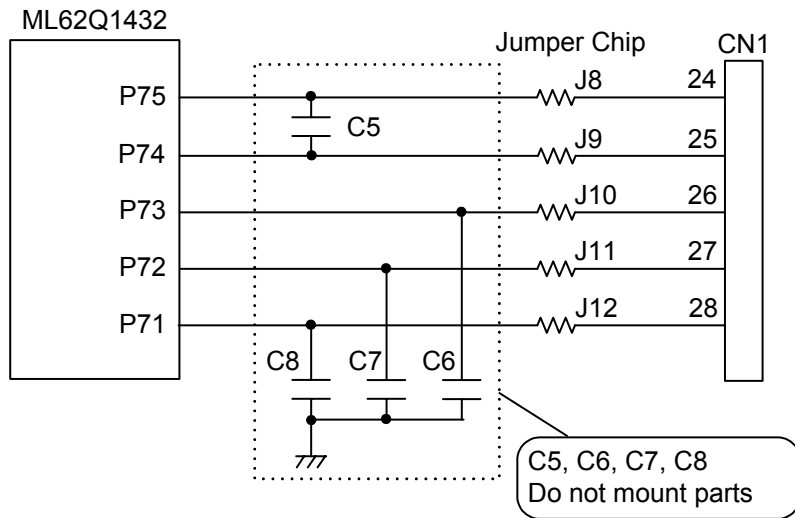

Fig.6 P75 - P71 Circuit

3. User Interface

Table 2. show the pin list of the ML62Q1432 Reference Board user interface connector CN1 and CN2.

Table 2. ML62Q1432 Reference Board CN1/CN2

CN1	NAME	CN1	NAME	CN2	NAME	CN2	NAME
1	XT0/PIO0	26	P73	1	V _{SS}	26	N.C.
2	XT1/PIO1	27	P72	2	V _{DD}	27	N.C.
3	V _{DD}	28	P71	3	N.C.	28	N.C.
4	V _{SS}	29	N.C.	4	N.C.	29	N.C.
5	N.C.	30	P04	5	N.C.	30	N.C.
6	RESET_N	31	P05	6	N.C.	31	N.C.
7	P00/TEST0	32	P06	7	P14	32	N.C.
8	P01	33	P07	8	P15	33	N.C.
9	N.C.	34	P10	9	P16	34	P30
10	N.C.	35	P11	10	P17	35	P31
11	N.C.	36	P12	11	P20	36	P32
12	N.C.	37	P13	12	P21	37	P33
13	N.C.	38	P50	13	P22	38	P60
14	N.C.	39	N.C.	14	P23	39	P61
15	N.C.	40	N.C.	15	P24	40	P62
16	N.C.	41	N.C.	16	P25	41	P63
17	N.C.	42	N.C.	17	P26	42	P64
18	N.C.	43	N.C.	18	P27	43	P65
19	P02	44	N.C.	19	N.C.	44	P66
20	P03	45	N.C.	20	N.C.	45	N.C.
21	N.C.	46	N.C.	21	N.C.	46	N.C.
22	N.C.	47	N.C.	22	N.C.	47	N.C.
23	N.C.	48	N.C.	23	N.C.	48	N.C.
24	P75	49	N.C.	24	N.C.	49	N.C.
25	P74	50	N.C.	25	N.C.	50	P43

N.C. : Non-Connection

4. Precaution for use

- (1) The ML62Q1432 Reference Board is an unfinished product and intended for research and development and for expert use in the research and development facility only. The ML62Q1432 Reference Board is not intended for use for volume production or parts thereof.
- (2) Since the content specified herein is subject to change for improvement without notice, confirm the content is the latest when using the board.
- (3) See another documents ML62Q1000 series user's manual and EASE1000 user's manual when using the ML62Q1432 Reference Board.
- (4) Confirm the final electrical characteristics by using the mass production parts on your mass production boards.
- (5) LAPIS support replacing the board for an initial failure soon after the shipment, can not support repairing the board.
- (6) ML62Q1432 Reference Board have signal patterns on the underside, it might work in abnormal if using on conductive materials. Use it on insulating materials or having any preventable parts.

5. PCB specification, BOM and Schematic

5.1 ML62Q1432 Reference Board PCB specification

Figure 5. shows the Reference Board PCB dimensional outline drawing and layout of components.

PCB part number:
RB-D62Q1432TB48

Dimension:
55.88 mm x 93.98 mm

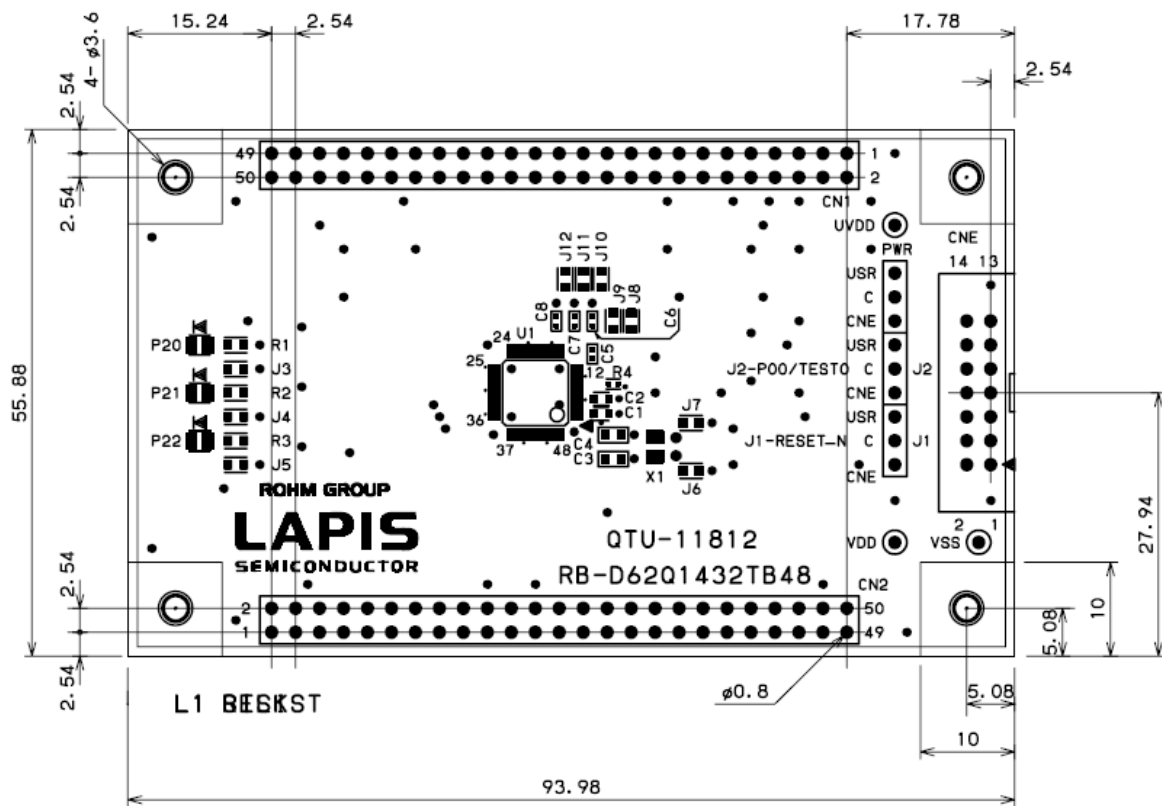

Fig.7 Reference Board PCB dimensional outline drawing and layout of components (Top view)

5.2 ML62Q1432 Reference Board BOM

Table 3. Reference Board BOM

	Parts Number	Silk	Contents	Package Type	Qty.	Maker
1	QTU-11787	RB-D62Q1432TB48	PCB	-	1	LAPIS
2	ML62Q1432TQFP48	U1	ML62Q1432TQFP48	TQFP48	1	LAPIS
3	MCR03ERTJ000	J3, J4, J5, J8,J9,J10,J11,J12,	Jumper Chip	1608(1.6x0.8mm)	8	ROHM
4	SML-210PT	P20, P21, P22	ChipLED (Green)	2012(2.0x1.2mm)	3	ROHM
5	MCR03EZJ271	R1, R2, R3	Chip Resistor 270Ω	1608(1.6x0.8mm)	3	ROHM
6	MCR01MZPJ103	R4	Chip Resistor 10kΩ	1005(1.0x0.5mm)	1	ROHM
7	GRM188R7YA105KA12D	C1, C2	Ceramic Capacitor 1uF/35V	1608(1.6x0.8mm)	2	MURATA
8	GRM1885C1H160FA01D	C3,C4	Ceramic Capacitor 16pF/50V	1608(1.6x0.8mm)	2	MURATA
9	HIF3FC-14PA-2.54DSA	CNE	14pin Connector	14pin DIP	1	HIROSE
10	VT-200-F	X1	32.768kHz	2pin DIP	1	SII
11	A2-3PA-2.54DSA	J1, J2, PWR	3pin Pin_Header	3pin DIP Straight	3	HIROSE
12	HIF3GA-2.54SP	-	Short pin	-	3	HIROSE
13	FF013-AR79	-	Rubber leg	-	4	KOYO FASTENER
14	P3555	-	Push rivet	-	4	KOYO FASTENER
15	A1-50PA-2.54DSA (Unmounted)	CN1, CN2	50pin 2.54pitch φ0.8 mm	50pin Straight	2	HIROSE
16	MCR03ERTJ000 (Unmounted)	J6,J7	Jumper Chip	608(1.6x0.8mm)	2	ROHM
17	Check Pin (Unmounted)	VDD, VSS	φ0.8 mm	-	2	-

[Note]

- The diameter of through hole of CN1 and CN2 is 0.8 mm.
Using CN1 and CN2, the diameter of connector pin should use the connector below 0.8mm, such as 0.5mm.
- The parts may be changed into another parts with equivalent part special quality.

5.3 ML62Q1432 Reference Board Schematic

The next page shows the schematic of ML62Q1432 Reference Board

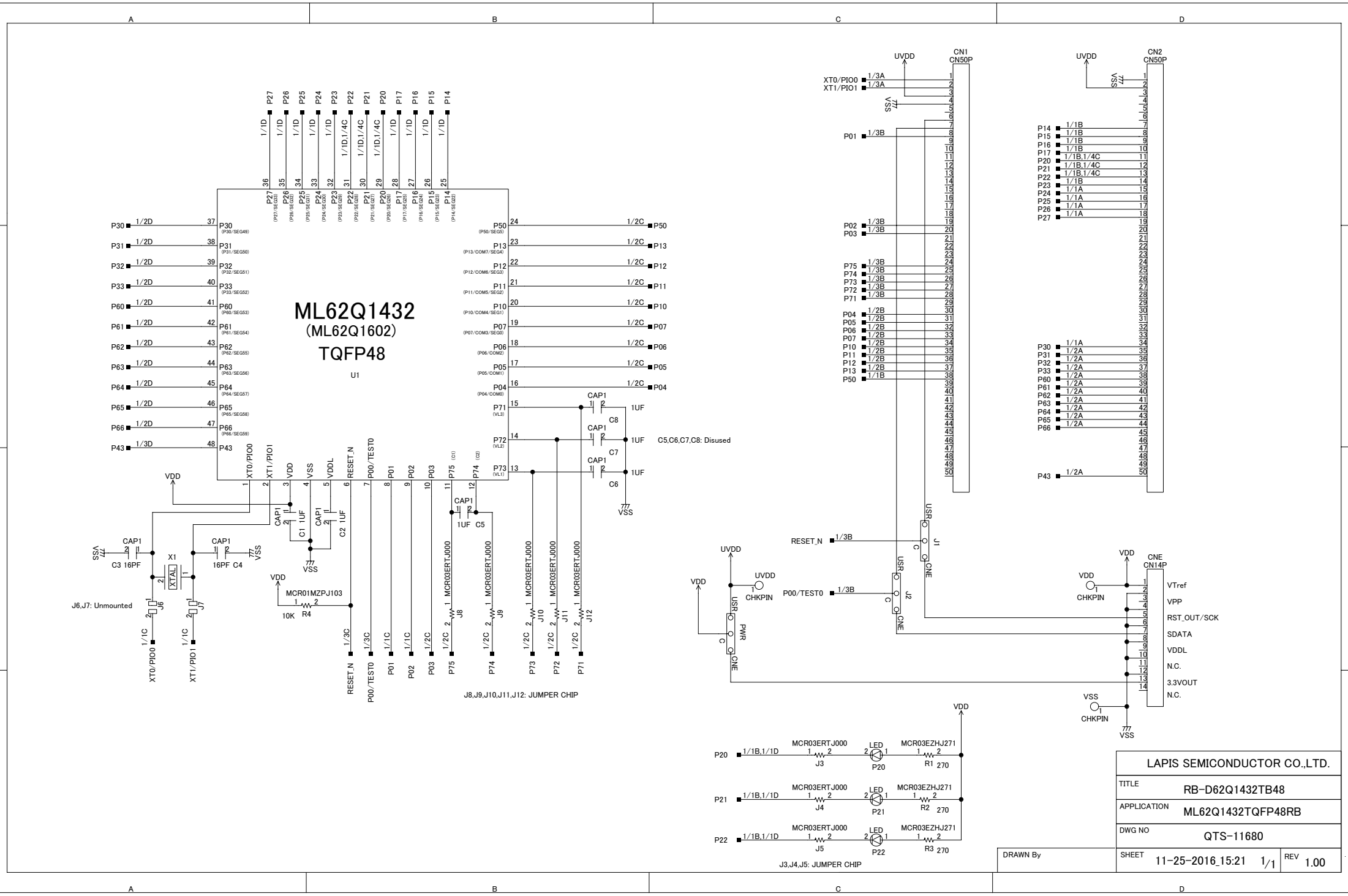

ML62Q1432
(ML62Q1602)
TQFP48

U1

P14	1/1B	7
P15	1/1B	8
P16	1/1B	9
P17	1/1B,1/4C	10
P20	1/1B,1/4C	11
P21	1/1B,1/4C	12
P22	1/1B	13
P23	1/1A	14
P24	1/1A	15
P25	1/1A	16
P26	1/1A	17
P27	1/1A	18
P30	1/1A	19
P31	1/2A	20
P32	1/2A	21
P33	1/2A	22
P60	1/2A	23
P61	1/2A	24
P62	1/2A	25
P63	1/2A	26
P64	1/2A	27
P65	1/2A	28
P66	1/2A	29
P43	1/2A	30

LAPIS SEMICONDUCTOR CO.,LTD.	
TITLE	RB-D62Q1432TB48
APPLICATION	ML62Q1432TQFP48RB
DWG NO	QTS-11680
SHEET	11-25-2016_15:21 1/1
REV	1.00

DRAWN By

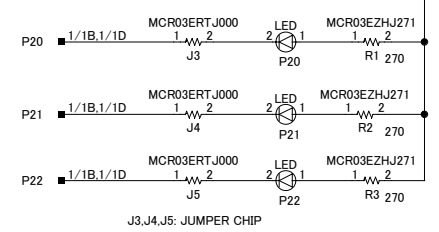

J3,J4,J5: JUMPER CHIP

J8,J9,J10,J11,J12: JUMPER CHIP

C5,C6,C7,C8: Disused

J6,J7: Unmounted

REVISION HISTORY

Document No.	Date	Page		Description
		Previous Edition	Current Edition	
FEBL62Q1432RB-01	April 7, 2017	-	-	First Edition
FEBL62Q1432RB-02	Aug. 1, 2017	4	4	Fig.1 changed
		11	11	Fig.7 changed
		12	12	Table3 Cap changed
FEBL62Q1432RB-03	October 10,2017	12	12	Table3 Corrected C1, C2