

LxEASE™ User's Manual

Arm® Cortex®-M Core compatible debug adapter

* LxEASE™ is a trademark or registered trademark of ROHM Co., Ltd.

* Arm® and Cortex® are registered trademarks of Arm Limited (or its subsidiaries or affiliates) in the United States and other countries.

Notice

Precaution on using ROHM Products

- 1) When using ROHM Products, refer to the latest product information and ensure that usage conditions (absolute maximum ratings*1, recommended operating conditions, etc.) are within the ranges specified. ROHM disclaims any and all liability for any malfunctions, failure or accident arising out of or in connection with the use of ROHM Products outside of such usage conditions specified ranges, or without observing precautions. Even if it is used within such usage conditions specified ranges, semiconductors can break down and malfunction due to various factors. Therefore, in order to prevent personal injury, fire or the other damage from break down or malfunction of ROHM Products, please take safety at your own risk measures such as complying with the derating characteristics, implementing redundant and fire prevention designs, and utilizing backups and fail-safe procedures.
*1: Absolute maximum ratings: a limit value that must not be exceeded even momentarily.
- 2) The Products specified in this document are not designed to be radiation tolerant.
- 3) Descriptions of circuits, software and other related information in this document are provided only to illustrate the standard operation of semiconductor products and application examples. You are fully responsible for the incorporation or any other use of the circuits, software, and information in the design of your product or system. And the peripheral conditions must be taken into account when designing circuits for mass production. ROHM disclaims any and all liability for any losses and damages incurred by you or third parties arising from the use of these circuits, software, and other related information.
- 4) No license, expressly or implied, is granted hereby under any intellectual property rights or other rights of ROHM or any third party with respect to ROHM Products or the information contained in this document (including but not limited to, the Product data, drawings, charts, programs, algorithms, and application examples, etc.). Therefore, ROHM shall have no responsibility whatsoever for any dispute, concerning such rights owned by third parties, arising out of the use of such technical information.
- 5) ROHM intends our Products to be used in a way indicated in this document. Please be sure to contact a ROHM sales office if you consider the use of our Products in different way from original use indicated in this document. For use of our Products in medical systems, please be sure to contact a ROHM representative and must obtain written agreement. Do not use our Products in applications which may directly cause injuries to human life, and which require extremely high reliability, such as aerospace equipment, nuclear power control systems, and submarine repeaters, etc. ROHM disclaims any and all liability for any losses and damages incurred by you or third parties arising by using the Product for purposes not intended by us without our prior written consent.
- 6) Please use the Products in accordance with any applicable environmental laws and regulations, such as the RoHS Directive. ROHM shall have no responsibility for any damages or losses resulting non-compliance with any applicable laws or regulations.
- 7) When providing our Products and technologies contained in this document to other countries, you must abide by the procedures and provisions stipulated in all applicable export laws and regulations, including without limitation the US Export Administration Regulations and the Foreign Exchange and Foreign Trade Act.
- 8) Please contact a ROHM sales office if you have any questions regarding the information contained in this document or ROHM's Products.
- 9) This document, in part or in whole, may not be reprinted or reproduced without prior consent of ROHM.

(Note) "ROHM" as used in this document means ROHM Co., Ltd.

Other Precaution

- 1) All information contained in this document is subject to change for the purpose of improvement, etc. without any prior notice. Before purchasing or using ROHM Products, please confirm the latest information with a ROHM sales office.
- 2) ROHM has used reasonable care to ensure the accuracy of the information contained in this document, however, ROHM shall have no responsibility for any damages, expenses or losses arising from inaccuracy or errors of such information.

TSZ72037-01-001

Contents



Contents.....	4
Chapter 1 Introduction.....	5
For Safe and Proper Use.....	6
Safety Precautions	7
Terminology	9
Chapter 2 Overview	10
2. Overview	11
2.1 Product Overview	11
2.2 Package Contents	12
2.3 Appearance	13
2.4 CN1 TARGET connector	14
2.5 CN2 connector	14
2.6 Conditions of use.....	15
2.7 Target System Requirements.....	16
Chapter 3 Start-up.....	20
3. Start-up	21
3.1 Starting LxEASE.....	21
Chapter 4 Functions	22
4. Functions	23
4.1 On-Chip Debug Function	23
4.2 Indicators.....	23
4.3 Target Power Supply Output	25
4.4 Current Measurement	25
4.5 External Trigger I/O	25
4.6 Hot-Plug	25
Chapter 5 Precautions When Using LxEASE	26
5. Precautions When Using LxEASE.....	27
5.1 VDDOUT Terminal.....	27
5.2 Operating Environment	27
5.3 Cables	27
Chapter 6 Appendix	28
6. Appendix.....	29
6.1 Mechanical Information	29
6.2 Firmware Update.....	30
Revision history.....	31

Chapter 1 Introduction

For Safe and Proper Use

This User's Manual uses terminology and pictograms to help you use the product safely and correctly and to prevent injury to yourself and others as well as damage to property. The meanings are as follows.

Meanings of terms

 WARNING	Indicates a potentially hazardous situation which, if mishandled, could result in death or serious injury.
 CAUTION	Indicates a potentially hazardous situation which, if mishandled, could result in minor or moderate injury, or property damage.

Examples of pictograms



△ indicates the presence of a hazard and prompts caution. The symbol may include a specific warning (e.g., electric shock).









● indicates a required action or instruction. The symbol may include a specific instruction (e.g., unplug the power cord).









○ indicates a prohibited action. The symbol may include a specific prohibition (e.g., do not disassemble).





Safety Precautions

Be sure to read this page before using the product.

 WARNING	
●Do not use a voltage other than the specified voltage. Doing so may result in fire, electric shock, or malfunction.	
●Do not modify this product. Doing so may result in fire, electric shock, or malfunction.	
●If smoke, unusual odor, or any other abnormal condition occurs, immediately disconnect the USB cable from LxEASE™. If an external power supply is used, turn it OFF, then remove the AC adapter from the outlet. Continued use may result in fire, electric shock, or malfunction.	
●Do not install this product in locations exposed to water droplets or high humidity. Doing so may result in fire, electric shock, or malfunction.	
●Do not place objects on this product. Doing so may result in fire, electric shock, or malfunction.	
●If you notice any failure, stop using the product. Immediately disconnect the USB cable from LxEASE. If an external power supply is used, turn it OFF, then remove the AC adapter from the outlet. Continued use may result in fire or electric shock.	

 CAUTION	
●Do not use this product on unstable or inclined surfaces. It may fall and cause injury.	
●Do not use this product in environments with excessive vibration, strong electromagnetic fields, or corrosive gas. Cable connections may loosen or disconnect, which may result in fire, electric shock, or malfunction.	
●Do not use this product outside the specified operating temperature range, in direct sunlight, or in dusty locations. Doing so may result in fire, electric shock, or malfunction.	
●Use only the supplied cables and accessories. Using different items may result in fire, electric shock, or malfunction.	
●Do not use the supplied cables and accessories for anything other than this system. Doing so may result in fire, electric shock, or malfunction.	

Be sure to read this page before using the product.

 CAUTION	
<ul style="list-style-type: none"> ●Do not apply a voltage exceeding the maximum rating of each power supply to the VDD terminal of the user cable. Doing so may result in fire, electric shock, or malfunction. 	
<ul style="list-style-type: none"> ●Pay particular attention to the power ON/OFF sequence. Incorrect sequencing may result in fire, electric shock, or malfunction. 	
<ul style="list-style-type: none"> ●When connecting or disconnecting LxEASE and the target system, be sure to turn OFF both LxEASE and the target system. Connecting/disconnecting while powered may result in fire, electric shock, or malfunction. 	

 NOTE	
<ul style="list-style-type: none"> ●LxEASE is a debug adapter intended to support development of equipment using ROHM microcontrollers. Evaluate and confirm the safety and regulatory conformity of the final product yourself. 	
<ul style="list-style-type: none"> ●This product is intended for development and evaluation use; it is not intended for use as a finished consumer product. 	
<ul style="list-style-type: none"> ●For final confirmation of the target LSI electrical characteristics, perform evaluation without using LxEASE. 	
<ul style="list-style-type: none"> ●The warranty period for early failures of LxEASE is one (1) year. Failures caused by improper use or modification are not covered. 	
<ul style="list-style-type: none"> ●The content of this document may be changed without notice due to product and technical improvements. Confirm that you are using the latest information. 	

Terminology

Terms used in this User's Manual and their descriptions are shown below.

Term	Description
LxEASE	A debug adapter for ROHM microcontrollers equipped with Arm® Cortex®-M cores.
LEXIDE-Ω	A Windows® application running on a PC that controls the on-chip emulator functions of LxEASE.
Target system	A board on which the target LSI is mounted; used for debugging, flash programming, and flash erase operations via LxEASE.
Host PC	A PC on which LEXIDE-Ω and the USB driver are installed.
USB cable	A cable used to connect LxEASE and the host PC.
Target LSI	The LSI being debugged by LxEASE.
LxEASE interface cable	A cable used to connect LxEASE and the target system.

* Windows® is a registered trademark of Microsoft Corporation in the United States and other countries.

Chapter 2 Overview

2. Overview

2.1 Product Overview

LxEASE™ is a debug adapter for ROHM microcontrollers equipped with Arm® Cortex®-M cores (hereinafter, "target LSI"). It complies with the CMSIS-DAP standard and provides on-chip emulator functions when used in combination with LEXIDE-Ω.

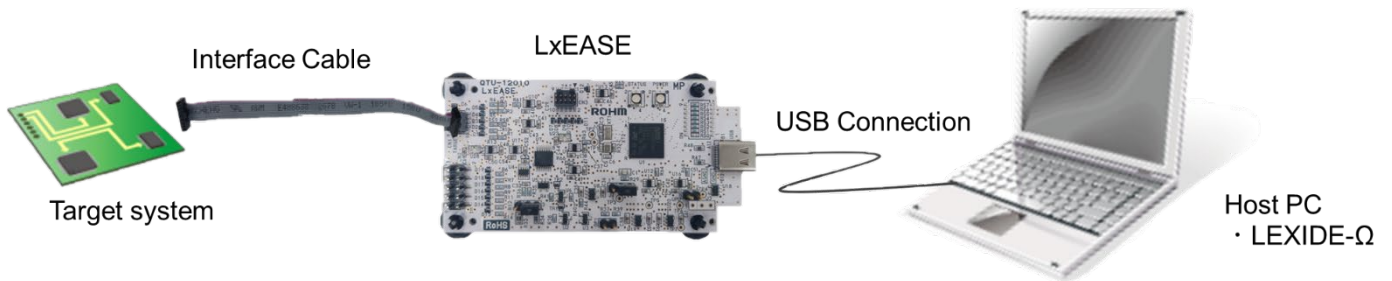

Figure 2-1 LxEASE System Configuration

2.2 Package Contents

The package contents of LxEASE are listed below.

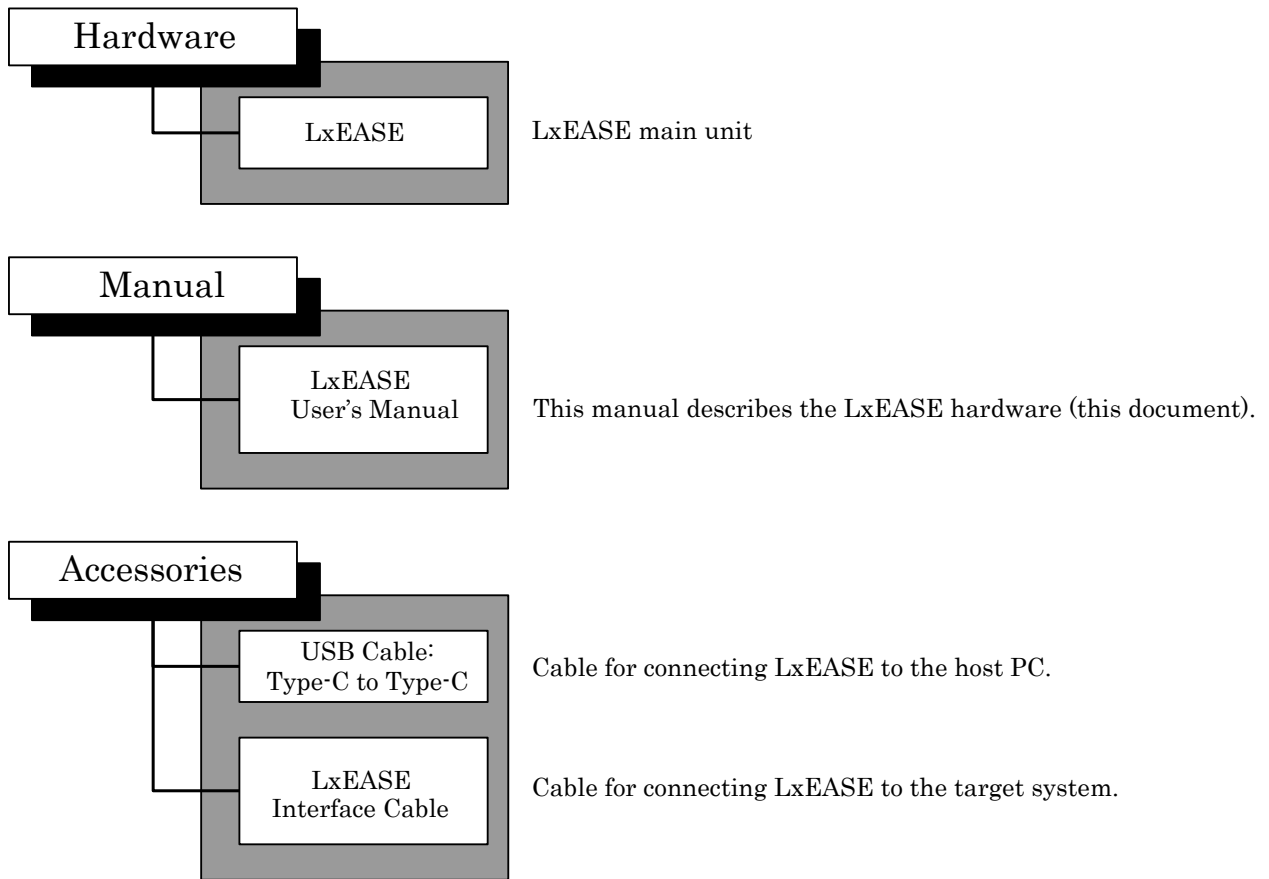

Figure 2-2 Package Contents

2.3 Appearance

The appearance of LxEASE and the description of each part are shown below. Names in parentheses indicate labels printed on the PCB.

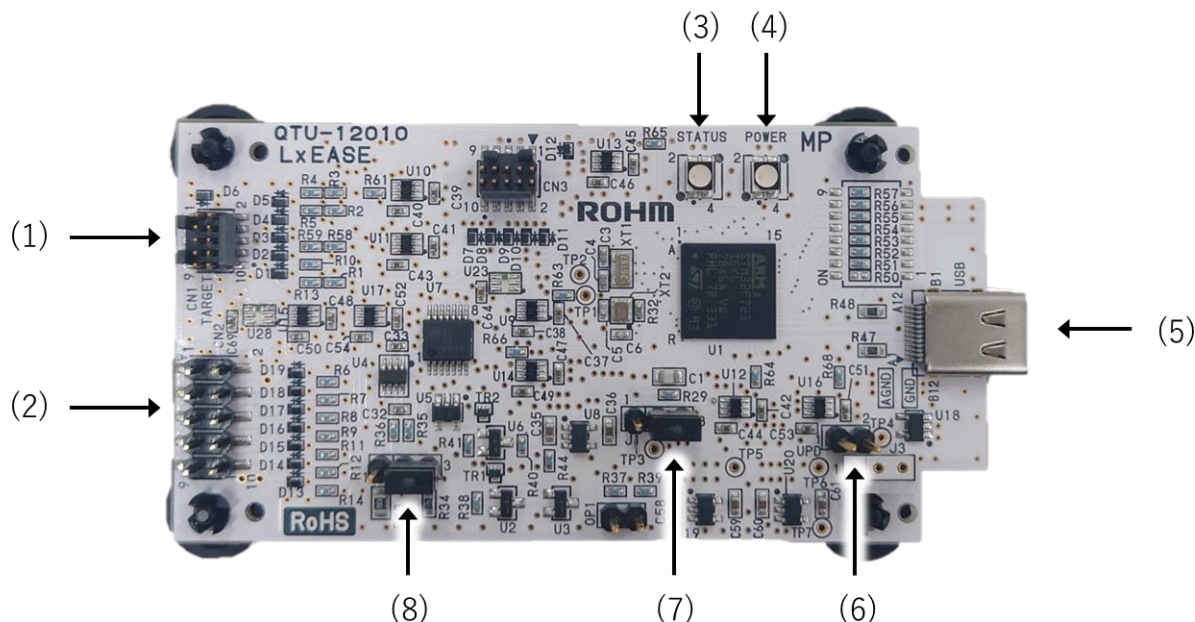

Figure 2-3 LxEASE Appearance (Top View)

Table 2-1 Description of Each Part

Part	Description
(1) CN1 TARGET	SWD interface for connecting LxEASE and the target system. Connect the supplied LxEASE interface cable. See Section 2.4 for details.
(2) CN2	Interface connector for target LSI power output, external trigger I/O, and hot-plug. See Section 2.5 for details. (Note 1)
(3) STATUS	LED indicating the operating status of LxEASE. See Section 4.2.
(4) POWER	LED indicating the power/firmware status of LxEASE. See Section 4.2.
(5) USB	USB Type-C connector for connecting to the host PC.
(6) UPD	Jumper pins for firmware update. See Section 6.2.
(7) J1	Jumper pins for selecting the target power output voltage. See Section 4.3.
(8) J2	Jumper pins for selecting the current measurement range. See Section 4.4.

Note 1: Test leads for CN2 connectors are not included. Prepare a test lead that corresponds to the connector pitch of 2.54 mm.

2.4 CN1 TARGET connector

The interface specifications of the CN1 TARGET connector are shown below.

Table 2-2 List of CN1 TARGET Connectors

Pin No.	Signal	I/O	Description
1	VTref	-	Target LSI reference voltage input (VDD).
2	SWDIO	I/O	SWD data signal.
3	VSS	-	Target LSI ground (VSS).
4	SWCLK	O	SWD clock signal.
5	VSS	-	Target LSI ground (VSS).
6	SWO	I	SWO trace signal.
7	N.C.	-	Not used (leave unconnected).
8	N.C.	-	Not used (leave unconnected).
9	VSS	-	Target LSI ground (VSS).
10	nRESET	O	Target LSI CPU reset signal.

2.5 CN2 connector

The interface specifications of the CN2 connector are shown below.

Table 2-3 List of CN2 Connectors

Pin No.	Signal	I/O	Description
1	VDDOUT	-	Target LSI power output (VDD).
2	VSS	-	Target LSI ground (VSS).
3	VTref	-	Target LSI reference voltage input (VDD).
4	TRGOUT1	O	External trigger output 1.
5	TRGOUT2	O	External trigger output 2.
6	TRGIN1	I	External trigger input 1.
7	TRGIN2	I	External trigger input 2.
8	RSV1	-	Reserved (leave unconnected).
9	RSV2	-	Reserved (leave unconnected).
10	RSV3	-	Reserved (leave unconnected).

2.6 Conditions of use

Use LxEASE under the following conditions.

Table 2-4 LxEASE usage conditions

Item	Specification
Power Supply	USB VBUS from host PC: 5.0 V, 500 mA (Type-A) or 900 mA (Type-C)
Usage Environment	Temperature: 5 to 40 °C / Humidity: 30 to 80 % (no condensation)
Target LSI Positive power supply voltage (VTref)	Target LSI operating voltage: 2.3 V to 5.5 V

For the operating environment of LEXIDE-Ω on the host PC, refer to the “LEXIDE-Ω Arm User’s Manual.”
The power that LxEASE can output to the target LSI is as follows:

Table 2-5 LxEASE Output Power

Item	Specification
Target power output (VDDOUT)	3.3 V or 5.0 V (USB bus power), 300 mA max

- Target power output is enabled after debugging starts in LEXIDE-Ω.

2.7 Target System Requirements

The target system that connects to the LxEASE must satisfy the following necessary requirements.

Table 2-6 Target system necessary items

Item	Requirement
Debug interface	10-pin, 1.27 mm pitch connector compatible with the LxEASE interface cable (conforming connector: FTSH-105-01-L-DV-K)
Target LSI positive supply (VDD)	2.3 V to 5.5 V (Note 1)
VTref input current	0.2 mA

Note 1: When VDD for the target system is supplied from the board side, LxEASE internally consumes the current shown in Table 2-6 during current-consumption measurement. Ensure that the board-side power supply has sufficient capacity, taking into account the current consumed by LxEASE.

2.7.1 Recommended Board Layout

The recommended board layout for the debug interface of the target system is shown below.

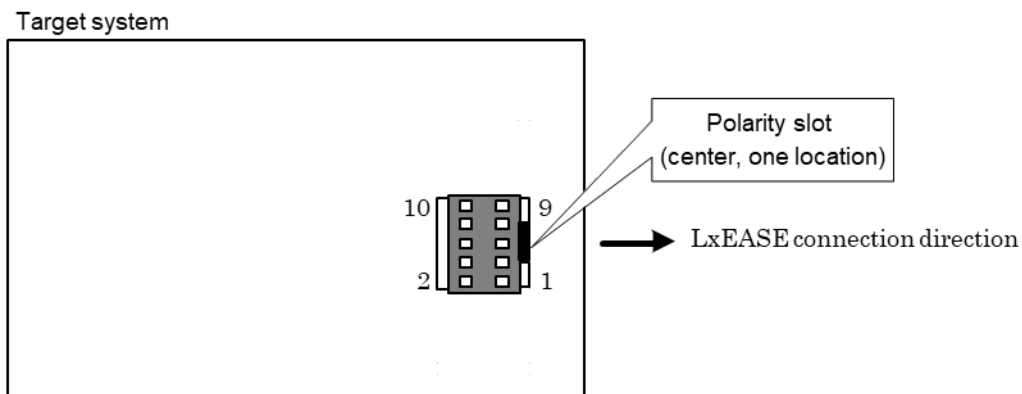

Figure 2-4 Example Target System Board Layout

The pin assignments of the debug interface are shown in the table below.

Table 2-8 Debug Interface Pin Assignment

Pin No.	LxEASE terminal name	I/O	Description
1	VTref	-	Target LSI power supply input terminal (VDD)
2	SWDIO	I/O	SWD data signal
3	VSS	-	Target LSI ground terminal (VSS)
4	SWCLK	O	SWD clock signal
5	VSS	-	Target LSI ground terminal (VSS)
6	SWO	I	SWO trace signal
7	N.C.	-	Not used (do not connect anything)
8	N.C.	-	Not used (do not connect anything)
9	VSS	-	Target LSI ground terminal (VSS)
10	nRESET	O	CPU reset signal of the target LSI

2.7.2 Supplying VDD to the Target LSI

2.7.2.1 When supplying power from LxEASE

LxEASE provides VDDOUT to supply 3.3 V or 5.0 V (USB bus power), up to 300 mA max, as the target LSI power source.

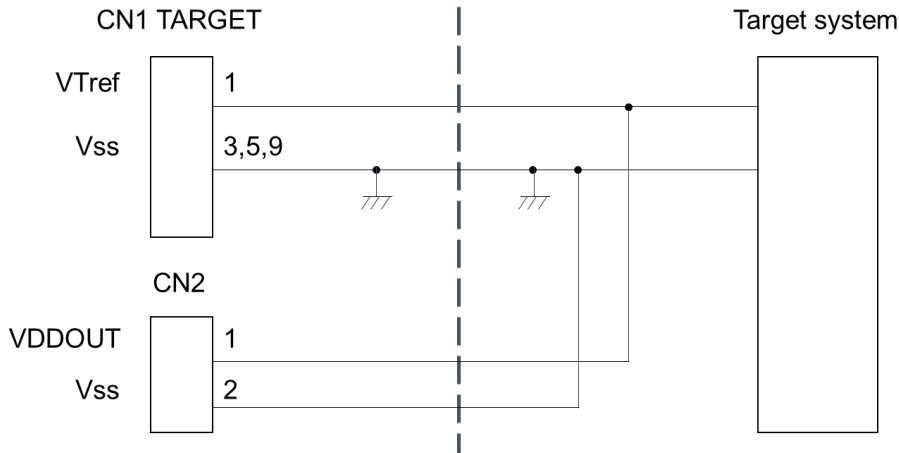

Figure 2-5 Connection Example (Using VDDOUT)



CAUTION

When using VDDOUT, do not apply another power supply to the target LSI VDD pin. Connecting two power sources may damage LxEASE and may result in electric shock or fire hazards.

2.7.2.2 When using the target system power supply

Below is an example of a circuit configuration in which LxEASE's VDDOUT is not used and the power supply on the target system is output to the VDD of the target LSI.

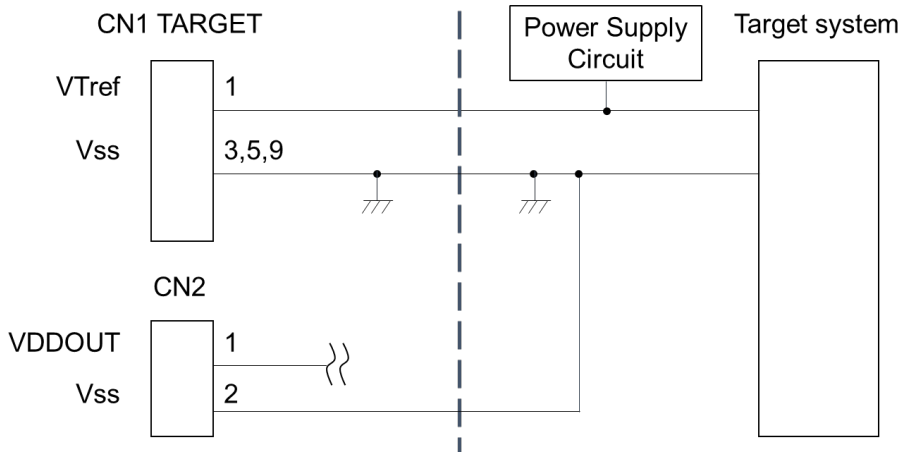

Figure 2-6 Connection Example (Using Target System Power Supply)



CAUTION

When using the target system power supply, do not connect VDDOUT and VTref. Doing so may damage LxEASE and may result in electric shock or fire hazards.

2.7.3 PCB Design Notes

Below are the precautions to be observed when creating the board.

- The LxEASE interface cable length is approximately 15 cm. Place the debug connector as close as possible to the PCB edge and route traces between the connector and the target LSI as short as possible (conforming connector: FTSH-105-01-L-DV-K).
- It is recommended to shield SWDIO, SWCLK, and SWO traces with adjacent VSS (GND) traces where possible.

Chapter 3 Start-up

3. Start-up

3.1 Starting LxEASE

To debug using LxEASE, connect the host PC, LxEASE, and the target system correctly, then power on and start LEXIDE-Ω in the specified order.

3.1.1 Connection Procedure

This section describes how to start LxEASE. Start the system according to the following startup procedure.

- (1) Connect the LxEASE main unit and the target system using the supplied LxEASE interface cable.
 - (2) Connect LxEASE to the host PC using the supplied USB cable. LxEASE operates on USB bus power. When the USB cable is connected, power is supplied and the POWER indicator lights green.
 - (3) Turn ON the target system power.
 - (4) Start LEXIDE-Ω on the host PC and begin debugging.
- ※ Refer to the “LEXIDE-Ω Arm User’s Manual” for details.

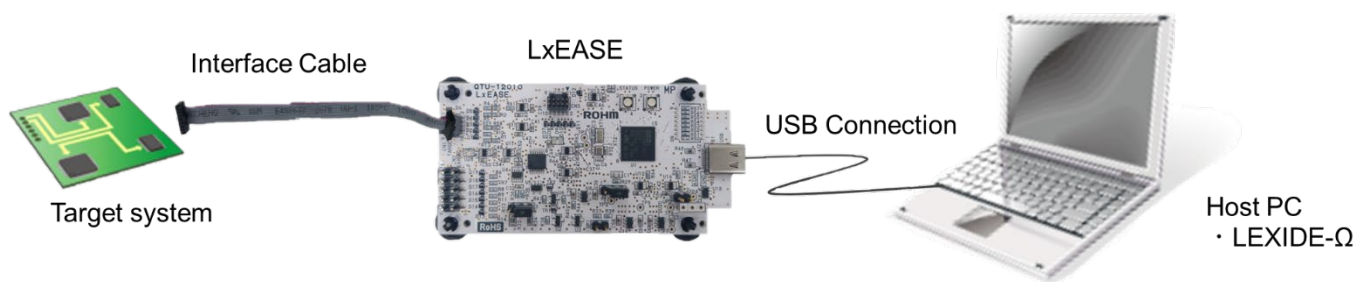

Figure 3-1 LxEASE System Configuration



CAUTION

Always follow the start-up procedure. If the order is incorrect, LxEASE and/or the target system may be damaged, and electric shock or fire hazards may occur.

3.1.2 Removal Procedure

Follow the procedure below to remove.

- (1) End debugging in LEXIDE-Ω on the host PC.
- (2) Turn OFF the target system power.
- (3) Disconnect the USB cable from LxEASE.
- (4) Disconnect the LxEASE interface cable between LxEASE and the target system.



CAUTION

Always follow the removal procedure. If the order is incorrect, LxEASE and/or the target system may be damaged, and electric shock or fire hazards may occur.

Chapter 4 Functions

4. Functions

4.1 On-Chip Debug Function

By connecting LxEASE to the target LSI and using LEXIDE-Ω, the following on-chip debug functions are available:

- Download, view, and modify application programs
- View and modify CPU status (registers, flash memory, data RAM, SFR)
- Emulation (run / single-step)
- Breakpoints
- Real-time monitor
- SWV (Serial Wire Viewer) (supported in UART mode only)

4.2 Indicators

The indicators on the LxEASE main unit show the operating status of LxEASE as described below.

Table 4-1 LxEASE Status – Indicator Light Status Correlation Table

Indicator	State	Meaning
POWER	Off	VBUS not supplied
	Green	VBUS supplied
	Blue	Firmware update
STATUS	Off	Disconnected (not electrically connected to the target LSI)
	Green	Idle (halted) / program memory write
	Blue	Emulation (running) / firmware update
	Red	Driver not recognized / communication error / overcurrent detected / VTref out of range / self-check error / firmware error

Descriptions of the above states are as follows:

Table 4-2 Description of LxEASE States

State	Description
Disconnected	LxEASE is not electrically connected to the target LSI. When debugging starts, it automatically connects to the target LSI.
Idle	The target LSI is halted (in break state).
Program memory write	Program memory is being written to the target LSI.
Emulation	The target LSI is running under emulation.
Firmware update	The LxEASE control firmware is being updated.
Driver not recognized	When LxEASE is powered on (USB connected), the host PC does not recognize that the device driver is installed. Follow the dialog displayed on the host PC to install the device driver.
Communication error	An error was detected during communication between LxEASE and the target LSI.
Overcurrent detected	The current consumption exceeded the selected current measurement range.
VTref out of range	The VTref voltage level input to LxEASE is outside the target LSI operating guarantee range. Check target connections and power output status.
Self-check error	LxEASE may be faulty. Immediately disconnect the USB cable from LxEASE. If an external power supply is used, turn it OFF and remove the AC adapter from the outlet. If connections are normal but the problem persists, contact your distributor or ROHM sales representative.
Firmware error	The control firmware data is corrupted. Update the firmware. If the problem persists, contact your distributor or ROHM sales representative.

4.3 Target Power Supply Output

LxEASE provides a VDDOUT output of either 3.3 V or 5.0 V (USB bus power) for use as the operating power supply of the target LSI. The output voltage can be selected using jumper J1, as shown in Table 4-3.

Note: Change the J1 jumper only when LxEASE is powered OFF (USB cable disconnected). For connection examples, see Section 2.7.2. For the VDDOUT pin location, see Section 2.5.

Table 4-3 Setting the Power Supply Voltage for the Target LSI

J1 setting	VDDOUT
Short pins 1–2	3.3 V
Short pins 2–3	5.0 V (USB bus power)

Note: If the current consumption exceeds the current measurement range configured in “4.4 Current Measurement”, power output is stopped and debugging ends. Even when the current measurement function is not used, power is supplied through the shunt resistor. Therefore, when the current measurement function is not used, it is recommended to set the current measurement range to 300 mA.

Note: If the current consumption exceeds the selected range, power output is forcibly stopped and debugging

4.4 Current Measurement

When supplying the operating power to the target LSI from LxEASE, the target system's current consumption can be measured. Use jumper J2 to select the current-measurement range, as shown in Table 4-4.

Note: Change J2 only when LxEASE is powered OFF (USB cable disconnected).

Table 4-4 Setting of current measurement range

J2 setting	Range	Resolution
Short pins 1–2	Up to 300 mA	77.7 μ A
Short pins 2–3	Up to 20 mA	6.1 μ A

Note: If the current consumption exceeds the selected range, power output is forcibly stopped and debugging ends. To debug again, power-cycle LxEASE (disconnect and reconnect the USB cable).

4.5 External Trigger I/O

LxEASE provides external trigger input and external trigger output functions.

Note:

- For configuration of the external trigger function on LEXIDE- Ω , refer to the “LEXIDE- Ω Arm User's Manual.”
- For the external trigger input and output terminals, refer to “2.5 CN2 Connector.”

4.6 Hot-Plug

Hot-plug allows you to connect LxEASE and start on-chip debugging while the target system is running.

Follow the procedure below:

- (1) Connect LxEASE to the host PC using the supplied USB cable. The POWER indicator lights green.
- (2) Connect CN2 pin 2 (VSS) to the target system VSS.
- (3) Connect LxEASE and the target system using the supplied LxEASE interface cable.
- (4) Start LEXIDE- Ω on the host PC.
- (5) Configure hot-plug in LEXIDE- Ω , then start debugging.

For CN2 pin assignments, see Section 2.5. For hot-plug settings in LEXIDE- Ω , refer to the “LEXIDE- Ω Arm User's Manual.”

Chapter 5 Precautions When Using LxEASE

5. Precautions When Using LxEASE

5.1 VDDOUT Terminal

The VDDOUT specifications are 3.3 V or 5.0 V, 300 mA max. When connecting VDDOUT to a target system, be sure to stay within these specifications. Exceeding the specifications may cause failure of the target system or LxEASE.

5.2 Operating Environment

LxEASE operation may be affected by external conditions such as the host PC, USB cable, interface cable, target system, and surrounding equipment. Verify operation in your environment before use.

In environments with frequent electrostatic discharge (ESD) or strong electromagnetic interference, temporary communication errors or debug interruptions may occur. For stable operation, use a low-noise environment where possible and implement grounding and shielding as necessary.

Cable routing and nearby equipment may influence operation. Keep cables as short as possible and avoid forming loops to help ensure stable operation.

LxEASE is a debug adapter intended to support development of equipment using ROHM microcontrollers. Evaluate and confirm the safety and regulatory conformity of the final product yourself.

5.3 Cables

Use only the USB cable and LxEASE interface cable supplied as LxEASE accessories.

Proper operation cannot be guaranteed when using other cables.

Using other cables may cause malfunctions or damage to LxEASE and/or the target system.

Chapter 6 Appendix

6. Appendix

6.1 Mechanical Information

6.1.1 LxEASE Main Unit

Item	Specification
External dimensions	45 × 15.3 × 90 mm (W × H × D)

6.1.2 LxEASE Interface Cable

Item	Specification
Cable length	Approx. 15 cm (excluding connectors)
Connector	1.27 mm pitch, 10-pin, 2-row socket (with a center polarization key)

6.1.3 USB Cable

Item	Specification
Cable length	Approx. 50 cm
Connector	Host PC: USB Type-C / LxEASE: USB Type-C

6.1.4 LxEASE Interface Cable Appearance

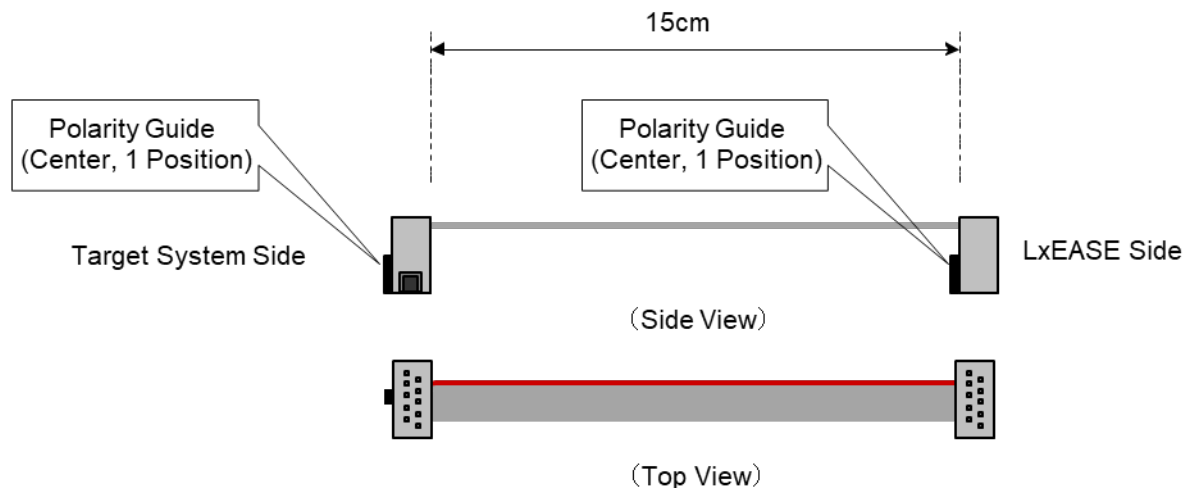

Figure 6-1 LxEASE Interface Cable Appearance

6.2 Firmware Update

To update the firmware, follow the procedure below.

Note: For how to launch and use “Firmware Updater for LAPIS ICE,” refer to its User’s Manual.

- (1) Turn OFF LxEASE (disconnect the USB cable).
- (2) Short the jumper pins labeled “UPD” located at the lower-right area of the PCB.
- (3) Connect LxEASE to the host PC.
- (4) Start “Firmware Updater for LAPIS ICE” and execute the update according to the on-screen instructions.
- (5) After the update completes, turn OFF LxEASE (disconnect the USB cable).
- (6) Restore the “UPD” jumper to its original state (open).

[Precautions]

Note 1: Perform firmware updates with a stable power supply. Power interruption during an update may cause failure.

Note 2: Always change jumper settings only when LxEASE is powered OFF (USB cable disconnected).

Revision history

Revision history

Version	Issue date	Page (before)	Page (after)	Description
First edition	2026-01-23	–	–	First edition published

Notice

- 1) The information contained in this document is intended to introduce ROHM Group (hereafter referred to as ROHM) products. When using ROHM products, please verify the latest specifications or datasheets before use.
- 2) ROHM products are designed and manufactured for use in general electronic equipment and applications (such as Audio Visual equipment, Office Automation equipment, telecommunication equipment, home appliances, amusement devices, etc.) or specified in the datasheets. Therefore, please contact the ROHM sales representative before using ROHM products in equipment or devices requiring extremely high reliability and whose failure or malfunction may cause danger or injury to human life or body or other serious damage (such as medical equipment, transportation, traffic, aircraft, spacecraft, nuclear power controllers, fuel control, automotive equipment including car accessories, etc. hereafter referred to as Specific Applications). Unless otherwise agreed in writing by ROHM in advance, ROHM shall not be in any way responsible or liable for any damages, expenses, or losses incurred by you or third parties arising from the use of ROHM Products for Specific Applications.
- 3) Electronic components, including semiconductors, can fail or malfunction at a certain rate. Please be sure to implement, at your own responsibilities, adequate safety measures including but not limited to fail-safe design against physical injury, and damage to any property, which a failure or malfunction of products may cause.
- 4) The information contained in this document, including application circuit examples and their constants, is intended to explain the standard operation and usage of ROHM products, and is not intended to guarantee, either explicitly or implicitly, the operation of the product in the actual equipment it will be used. As a result, you are solely responsible for it, and you must exercise your own independent verification and judgment in the use of such information contained in this document. ROHM shall not be in any way responsible or liable for any damages, expenses, or losses incurred by you or third parties arising from the use of such information.
- 5) When exporting ROHM products or technologies described in this document to other countries, you must abide by the procedures and provisions stipulated in all applicable export laws and regulations, such as the Foreign Exchange and Foreign Trade Act and the US Export Administration Regulations, and follow the necessary procedures in accordance with these provisions.
- 6) The technical information and data described in this document, including typical application circuits, are examples only and are not intended to guarantee to be free from infringement of third parties intellectual property or other rights. ROHM does not grant any license, express or implied, to implement, use, or exploit any intellectual property or other rights owned or controlled by ROHM or any third parties with respect to the information contained herein.
- 7) No part of this document may be reprinted or reproduced in any form by any means without the prior written consent of ROHM.
- 8) All information contained in this document is current as of the date of publication and subject to change without notice. Before purchasing or using ROHM products, please confirm the latest information with the ROHM sales representative.
- 9) ROHM does not warrant that the information contained herein is error-free. ROHM shall not be in any way responsible or liable for any damages, expenses, or losses incurred by you or third parties resulting from errors contained in this document.



Thank you for your accessing to ROHM product informations.
More detail product informations and catalogs are available, please contact us.

ROHM Customer Support System

<https://www.rohm.com/contactus>